

SERVICE MANUAL

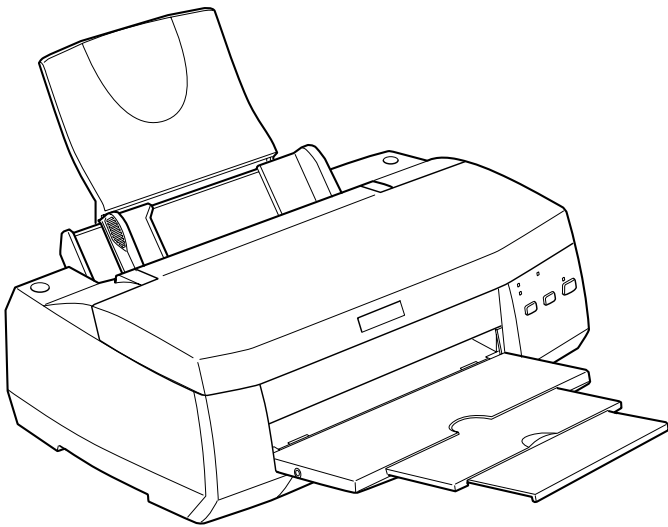

Color ink jet printer

EPSON Stylus Color 980



EPSON®

SEIJ00012

Notice:

- All rights reserved. No part of this manual may be reproduced, stored in a retrieval system, or transmitted in any form or by any means, electronic, mechanical, photocopying, recording, or otherwise, without the prior written permission of SEIKO EPSON CORPORATION.
- The contents of this manual are subject to change without notice.
- All effort have been made to ensure the accuracy of the contents of this manual. However, should any errors be detected, SEIKO EPSON would greatly appreciate being informed of them.
- The above notwithstanding SEIKO EPSON CORPORATION can assume no responsibility for any errors in this manual or the consequences thereof.

EPSON is a registered trademark of SEIKO EPSON CORPORATION.

General Notice: Other product names used herein are for identification purpose only and may be trademarks or registered trademarks of their respective owners. EPSON disclaims any and all rights in those marks.

Copyright © 1996 SEIKO EPSON CORPORATION. Printed in Japan.

PRECAUTIONS

Precautionary notations throughout the text are categorized relative to 1) Personal injury and 2) damage to equipment.

DANGER Signals a precaution which, if ignored, could result in serious or fatal personal injury. Great caution should be exercised in performing procedures preceded by DANGER Headings.

WARNING Signals a precaution which, if ignored, could result in damage to equipment.

The precautionary measures itemized below should always be observed when performing repair/maintenance procedures.

DANGER

1. ALWAYS DISCONNECT THE PRODUCT FROM THE POWER SOURCE AND PERIPHERAL DEVICES PERFORMING ANY MAINTENANCE OR REPAIR PROCEDURES.
2. NOWORK SHOULD BE PERFORMED ON THE UNIT BY PERSONS UNFAMILIAR WITH BASIC SAFETY MEASURES AS DICTATED FOR ALL ELECTRONICS TECHNICIANS IN THEIR LINE OF WORK.
3. WHEN PERFORMING TESTING AS DICTATED WITHIN THIS MANUAL, DO NOT CONNECT THE UNIT TO A POWER SOURCE UNTIL INSTRUCTED TO DO SO. WHEN THE POWER SUPPLY CABLE MUST BE CONNECTED, USE EXTREME CAUTION IN WORKING ON POWER SUPPLY AND OTHER ELECTRONIC COMPONENTS.

WARNING

1. REPAIRS ON EPSON PRODUCT SHOULD BE PERFORMED ONLY BY AN EPSON CERTIFIED REPAIR TECHNICIAN.
2. MAKE CERTAIN THAT THE SOURCE VOLTAGES IS THE SAME AS THE RATED VOLTAGE, LISTED ON THE SERIAL NUMBER/RATING PLATE. IF THE EPSON PRODUCT HAS A PRIMARY AC RATING DIFFERENT FROM AVAILABLE POWER SOURCE, DO NOT CONNECT IT TO THE POWER SOURCE.
3. ALWAYS VERIFY THAT THE EPSON PRODUCT HAS BEEN DISCONNECTED FROM THE POWER SOURCE BEFORE REMOVING OR REPLACING PRINTED CIRCUIT BOARDS AND/OR INDIVIDUAL CHIPS.
4. IN ORDER TO PROTECT SENSITIVE MICROPROCESSORS AND CIRCUITRY, USE STATIC DISCHARGE EQUIPMENT, SUCH AS ANTI-STATIC WRIST STRAPS, WHEN ACCESSING INTERNAL COMPONENTS.
5. REPLACE MALFUNCTIONING COMPONENTS ONLY WITH THOSE COMPONENTS BY THE MANUFACTURE; INTRODUCTION OF SECOND-SOURCE ICs OR OTHER NONAPPROVED COMPONENTS MAY DAMAGE THE PRODUCT AND VOID ANY APPLICABLE EPSON WARRANTY.

PREFACE

This manual describes basic functions, theory of electrical and mechanical operations, maintenance and repair procedures of Stylus Color 980. The instructions and procedures included herein are intended for the experienced repair technicians, and attention should be given to the precautions on the preceding page. The chapters are organized as follows:

CHAPTER 1. PRODUCT DESCRIPTIONS

Provides a general overview and specifications of the product.

CHAPTER 2. OPERATING PRINCIPLES

Describes the theory of electrical and mechanical operations of the product.

CHAPTER 3. TROUBLESHOOTING

Provides the step-by-step procedures for troubleshooting.

CHAPTER 4. DISASSEMBLY AND ASSEMBLY

Describes the step-by-step procedures for disassembling and assembling the product.

CHAPTER 5. ADJUSTMENTS

Provides Epson-approved methods for adjustment.

CHAPTER 6. MAINTENANCE

Provides preventive maintenance procedures and the lists of Epson-approved lubricants and adhesives required for servicing the product.

CHAPTER 7. APPENDIX

Provides the following additional information for reference:

- Connector pin assignments
- Electric circuit boards components layout
- Exploded diagram
- Electrical circuit boards schematics

Contents

Product Description

Features	5
Specifications	6
Printing Specifications	6
Options and Consumable Products	9
Paper Specifications	11
Cut Sheet	11
Transparency, Glossy Film	11
Envelope	11
Index Card	11
Self Adhesive Sheets	11
Photo Paper	12
Photo Stickers	12
Printable Area	13
Ink Cartridge Specifications	15
Black Ink Cartridge	15
Color Ink Cartridge	16
Electrical Specifications	17
Environmental Condition	17
Reliability	18
Safety Approvals	18
Acoustic Noise	18
CE Marking (220 ~ 240 V version)	18
Physical Specifications	18
Interface	19
Parallel Interface (Forward Channel)	19
Parallel Interface (Reverse Channel)	22
USB Interface	24
Optional interface	24
Printer Language and Emulation	27
Prevention Hosts from Data Transfer time-out	27
Auto Interface Selection	27

IEEE 1284.4 Protocol	28
Control Panel Operation	29
Indicators (LEDs)	29
Panel Functions	30
Printer Setting Mode	30
Special Setting Mode	32
Printer Condition and Panel Status	33
Error Status	34
Ink Out	34
Paper Out	34
Paper Jam	34
No Ink Cartridge	34
Maintenance Request	34
Fatal Errors	34
Double Feed Errors	34
Printer Initialization	35
Component Layout	36
Printer Mechanism	36
C380 Main Board	37
C265 PSB/PSE Board	39
C265 PNL Board	40
C265 Relay Board	40

Operating Principles

Overview	42
Printer Mechanism Operating Principles	42
Carriage Mechanism	44
Printing Mechanism	46
Paper Load Mechanism	47
Paper Feed Mechanism	49
Pump/ASF Switch Mechanism	50

Pump / Carriage Lock / Head Cleaner Mechanism	52
Electrical Circuit Operation Principles	54
C265 PSB/PSE Power Supply Board	54
C380 Main Board	57
CR Motor Driver Circuit	65
PF Motor Driver Circuit	67
Pump/ASF Motor Driver Circuit	69
Printhead Driver Circuit	70
Cooling Fan Driver Circuit	72
ASF Solenoid Driver Circuit	74
EEPROM Control Driver Circuit	75

Troubleshooting

Overview	77
Troubleshooting with LED Error Indications	78
Remedies for Paper Out Error	79
Remedies for the Paper Jam Error	81
Remedies for No I/C and Ink Out Errors	83
Remedies for the Maintenance Error	85
Remedies for Fatal Error	86
Isolating the Faulty Part on the Power Supply Board	88
Isolating the Faulty Part according to the Phenomenon	90

Disassembly and Assembly

Overview	100
Precautions for Disassembling the Printer	100
Disassembly Procedures	102
Upper Case and Control Panel Removal	104
Printer Mechanism Removal	105
C380 Main Board Unit Removal	106
Relay Board and Cooling Fan Removal	107
Shield Plate on the C380 Main Board Removal	108
C265 PSB/PSE Board Removal	109
Printer Mechanism Disassembly	111
Printhead Removal	111
CR Motor Removal	113
PF Motor Removal	114
Pump/ASF Motor and Solenoid Removal	115

ASF Unit Removal	115
ASF Disassembly 116	
ASF Sensor Removal	120
CRHP Sensor Removal	121
PE Sensor Removal	121
Encoder Belt Sensor Removal	122
Carriage Unit Removal	123
Pump Unit Removal	124
Paper Eject Frame Removal	125
Paper Eject Roller Removal	125
Platen Removal	126
PF Roller Removal	127

Adjustment

Overview	130
Conditions for Each Adjustment	130
Adjustments	133
Preliminary Operation	133
Head Actuator Voltage Input	135
Head ID Retrieval	136
Head Angular Adjustment	136
Bi-Directional Adjustment	137
USB ID Input	140
USB ID Retrieval	141
Printhead Cleaning Using the Program	142
Initial Ink Charge	143
Refurbishment for DOA	143
Indication of the Counter Value for the Waste Ink Pad	144
Fan Check	146
Paper Gap Adjustment	147

Maintenance

Overview	151
Maintenance	151
Cleaning the Printhead	152
Maintenance Request Error	153
Lubrication and Adhesion	154
Lubricating the Carriage Guide Shaft	155

Appendix

Connector Summary 161

EEPROM ADDRESS MAP 165

Component Layout 169

Parts List 173

Exploded Diagrams 176

Circuit Diagrams 184

CHAPTER

1

PRODUCT DESCRIPTION

1.1 FEATURES

The Stylus COLOR 980 is the latest in EPSON's advanced lines of ink jet printers and offering the following features.

- High color print quality:
 - 2880 (H) x1440 (V) dpi printing
 - Printing with 4 color inks (YMCK)
 - Traditional and New Microweave
 - Improvement in color rendering using variable dot
- Built-in auto sheet feeder:
 - Holds 100 cut-sheets (64 g/m²)
 - Holds 10 envelopes
 - Holds 30 transparency films
- Built-in 3 I/F
 - Bi-directional parallel I/F (IEEE-1284 level 1 device)
 - USB
 - Optional Type-B level 2 I/F card slot
- 4 scaleable fonts, 5 LQ fonts
- 13 character tables (Standard version)
- 37 character tables (NLSP version)
- Duplex printing mode

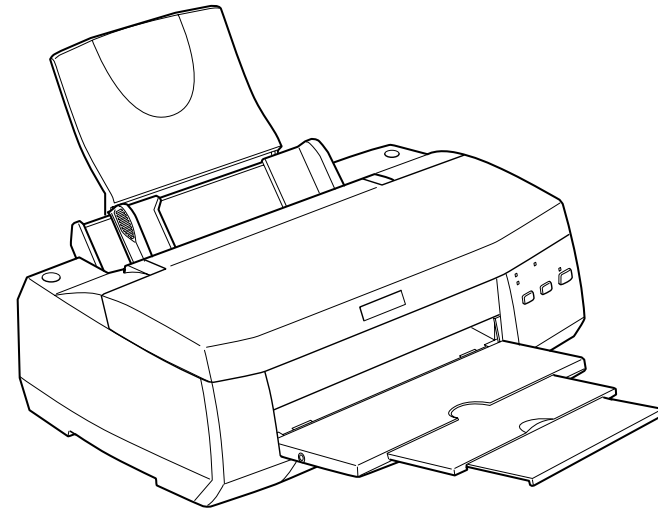

Figure 1-1. Stylus Color 980

1.2 Specifications

1.2.1 Printing Specifications

- Print method: On demand ink jet
- Nozzle configuration: Monochrome=192 nozzles (96 x 2 staggered)
Color=96 nozzles x 3 (Cyan, Magenta, Yellow)
(See Figure 1-2 for the nozzle configuration.)

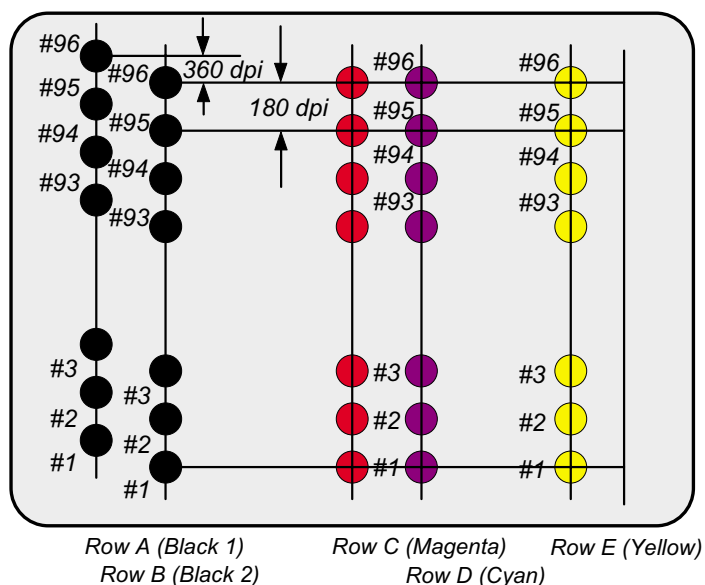

Figure 1-2. Nozzle configuration

- Print direction: Bi-direction with logic seeking
- Print speed and Printable columns

Table 1-1.
Print Speed and Printable Columns for Character Mode

Character pitch	Printable columns	LQ speed
10 CPI (Pica)	80	285 CPS
12 CPI (Elite)	96	342 CPS
15 CPI	120	428 CPS
17 CPI (Pica condensed)	137	487 CPS
20 CPI (Elite condensed)	160	570 CPS

Table 1-2.
Print Speed and Printable columns for Raster Graphics Mode

Horizontal resolution	Printable area	Available dot	CRS
180 dpi	8.26 inch	1488	28.5 IPS
360 dpi	8.26 inch	2976	28.5 IPS
720 dpi	8.26 inch	5952	20 IPS

- Control code: ESC/P2 and expanded raster graphics code
EPSON Remote command
IBM X24E emulation

Character tables: Legal and 14 international character sets

Standard version: (13 character tables)

Italic table	PC 860 (Portuguese)
PC 850 (Multilingual)	PC 437(US, Standard Europe)
PC 861 (Icelandic)	PC 863(Canadian-French)
PC 865(Nordic)	Abicomp
BRASCII	Roman 8
ISO Latin 1	PC 858
ISO 8859-15	

NLSP version: (36 character tables)

Italic table	PC437	PC437 Greek
PC850	PC852	PC853
PC855	PC857	PC860
PC861	PC865	PC866
PC869	MAZOWIA	Code MJK
ISO 8859-7	ISO Latin 1T	Bulgaria
PC774	Estonia	ISO 8859-2
PC866 LAT	PC866 UKR	PC AR864
PC APTEC	PC708	PC720
Hebrew7*	Hebrew8*	PC862*
Abicomp	BRASCII	Roman 8
ISO Latin 1	PC 858	ISO 8859-15

* These character tables can not be selected in the Default setting mode.

Typeface

Bit map LQ font:

EPSON Roman	10 CPI, 12 CPI, 15CPI, Proportional
EPSON Sans Serif	10 CPI, 12 CPI, 15CPI, Proportional
EPSON Courier	10 CPI, 12 CPI, 15CPI
EPSON Prestige	10 CPI, 12 CPI, 15CPI
EPSON Script	10 CPI, 12 CPI, 15CPI

Scaleable font

EPSON Roman	10.5 pt., 8 pt., - 32 pt. (every 2 pt.)
EPSON Sans Serif	10.5 pt., 8 pt., - 32 pt. (every 2 pt.)
EPSON Roman T	10.5 pt., 8 pt., - 32 pt. (every 2 pt.)
EPSON Sans Serif H	10.5 pt., 8 pt., - 32 pt. (every 2 pt.)

* Each Typeface has 4 variations as the following example of EPSON Roman.

EPSON Roman normal
EPSON Roman bold
EPSON Roman italic
EPSON Roman bold italic

See Table 1-3 which lists the character tables and available typefaces.

- Feeding method: Friction feed with ASF
- Line spacing: 1/6 inch, 1/8 inch or programable at 1/360 inch
- Paper path: Cut-sheet ASF (Top entry, Front out)
- Feed speed: 192/360 inch feed = 116 ms
 Continuous feed = 176.3 mm/second (6.94 inch/second)
- Input data buffer: 256 KB

Table 1-3. Character Tables and Available Typefaces

	Character Tables		Bit map font	Scaleable font
Standard version	Italic table	PC 437 (US Standard Europe)	EPSON Roman EPSON Sans Serif EPSON Courier	EPSON Roman EPSON Sans Serif
	PC 860 (Portuguese)	PC 850 (Multilingual)		
NLSP version	PC 861 (Icelandic)	PC 863 (Canadian-French)	EPSON Prestige EPSON Script	EPSON Roman T EPSON Sans Serif H
	PC 865 (Nordic)	BRASCII		
	Abicomp	Roman 8		
	ISO Latin1	PC 858		
	ISO 8859-15			
	Italic table	PC 437(US Standard Europe)		
	PC 850 (Multilingual)	PC 860(Portuguese)		
	PC 861 (Icelandic)	PC 865(Nordic)		
	Abicomp	BRASCII		
	ISOLatin1	Roman8		
ISO 8859-15	PC 858			
NLSP version	PC437Greek	PC 852 (East Europe)	EPSON Roman EPSON Sans Serif EPSON Courier EPSON Prestige EPSON Script	EPSON Roman EPSON Sans Serif
	PC 853 (Turkish)	PC 855 (Cyrillic)		
	PC 857 (Turkish)	PC 866 (Russian)		
	PC 869 (Greek)	MAZOWIA (Poland)		
	Code MJK (CSFR)	ISO 8859-7 (Latin/Greek)		
	ISO Latin 1T (Turkish)	Bulgaria (Bulgarian)		
	PC 774	Estonia		
	1SO 8859-2 (ISO Latin 2)	PC 866 LAT		
	PC 866 UKR			
	PC APTEC (Arabic)	PC 708 (Arabic)		
PC 720 (Arabic)	PC AR864 (Arabic)			
NLSP version	Hebrew7*		EPSON Roman EPSON Courier	Not supported
	Hebrew 8*			
	PC862 (Hebrew)*			

* Not mentioned in the User's Guide. These character tables can not select in the default setting mode.

1.2.2 Options and Consumable Products

NOTE: The asterisk (*) is a substitute for the last digit of the product number, which varies by country.

NOTE: The availability of special media varies by country.

Table 1-4. Options Available for Stylus Color 980

Items	Codes
Type B Multi-protocol Ethernet Interface Card	C82362*
Type B 100BASE-TX Multi-protocol Ethernet Interface Card	C82363*/C82364* C82384*
Type B IEEE1394 Interface Card	C82372*

Table 1-5. Ink Cartridge Available for Stylus Color 980

Items	Codes
Black Ink Cartridge	T003
Color Ink Cartridge	T005

See Table 1-6 and 1-7 which show the EPSON Special Media.

Table 1-6. EPSON Special Media

Items	Codes
EPSON 360 dpi Ink Jet Paper (A4)	S041059 / S041025
EPSON 360 dpi Ink Jet Paper (Letter)	S041060 / S041028
EPSON Photo Quality Ink Jet Paper (A4)	S041061 / S041026
EPSON Photo Quality Ink Jet Paper (Letter)	S041062 / S041029
EPSON Photo Quality Ink Jet Paper (Legal)	S041067 / S041048
EPSON Photo Quality Ink Jet Card (A6)	S041054
EPSON Photo Quality Ink Jet Card (5 x 8")	S041121
EPSON Photo Quality Ink Jet Card (8 x 10")	S041122
EPSON Photo Quality Self Adhesive Sheet (A4)	S041106
EPSON Ink Jet Note Card (A6) (with envelopes)	S041147
EPSON Ink Jet Greeting Cards (5 x 8") (with envelopes)	S041148
EPSON Ink Jet Greeting Cards (8 x 10") (with envelopes)	S041149
EPSON Photo Quality Glossy Film (A4)	S041071
EPSON Photo Quality Glossy Film (Letter)	S041072
EPSON Photo Quality Glossy Film (A6)	S041107
EPSON Ink Jet Transparencies (A4)	S041063
EPSON Ink Jet Transparencies (Letter)	S041064
EPSON Photo Paper (A4)	S041140
EPSON Photo Paper (Letter)	S041141
EPSON Photo Paper (4 x 6")	S041134
EPSON Photo Paper Cards (A4)	S041177
EPSON Photo Stickers 16 (A6)	S041144
EPSON Photo Stickers 4 (A6)	S041176
EPSON Panoramic Photo Paper (210 x 594 mm)	S041145
EPSON Iron-On Cool Peel Transfer Paper (A4)	S041154
EPSON Iron-On Cool Peel Transfer Paper (Letter)	S041153 / S041155

Table 1-7. EPSON Special Media (continued)

Items	Codes
EPSON Photo Paper (100 x 150mm)	S041255
EPSON Photo Paper (200 x 300mm)	S041254
EPSON Premium Ink Jet Plain Paper (A4)	S041214
EPSON Premium Glossy Photo Paper (A4)	S041287 / S041297
EPSON Premium Glossy Photo Paper (Letter)	S041286
EPSON Matte Paper-Heavy weight (A4)	S041256 / S041258 S041259
EPSON Matte Paper-Heavy weight (Letter)	S041257

1.2.3 Paper Specifications

This section describes paper specifications including paper handling and printable area.

- Paper Handling: Do not feed paper in reverse more than 9.5 mm (0.38").

1.2.3.1 Cut Sheet

- Size:
 - A4: [Width 210 mm (8.3") x Length 297 mm (11.7")]
 - A5: [Width 148 mm (5.8") x Length 210 mm (8.3")]
 - Letter: [Width 216 mm (8.5") x Length 279 mm (11.0")]
 - B5: [Width 182 mm (7.2") x Length 257 mm (10.1")]
 - Legal: [Width 216 mm (8.5") x Length 356 mm (14.0")]
 - Half Letter: [Width 139.7 mm (5.5") x Length 215.9 mm (8.5")]
 - Executive: [Width 184.2 mm (7.25") x Length 266.7mm(10.5")]
- Thickness: 0.08 mm (0.003") - 0.11 mm (0.004")
- Weight: 64g/m² (17lb.) - 90g/m² (24lb.)
- Paper Types: Bond paper, Plain paper, EPSON special media

1.2.3.2 Transparency, Glossy Film

- Size
 - A4: [Width 210 mm (8.3") x Length 297 mm (11.7")]
 - Letter: [Width 216 mm (8.5") x Length 279 mm (11.0")]
 - A6: [Width 105 mm (4.1") x Length 148 mm (5.8")]
- Thickness: 0.075 mm (0.003") - 0.085 mm (0.0033")
- Paper Types: EPSON special media

NOTE: Print on transparency at normal temperatures only.

1.2.3.3 Envelope

- Size:
 - No.10: [Width 241 mm (9 1/2") x Length 104.8 mm (4 1/8")]
 - DL: [Width 220 mm (8.7") x Length 110 mm (4.3")]
 - C6: [Width 162 mm (6.4") x Length 114 mm (4.5")]
 - 5 x 8": [Width 220 mm (8.7") x Length 132 mm (5.2")]
- Thickness: 0.16 mm (0.006") - 0.52 mm (0.02")
- Weight: 45g/m² (12lb.) - 75g/m² (20lb.)
- Paper Types: Bond paper, Plain paper, Air mail

NOTES:

1. Print on envelope at normal temperatures only.
2. Place the longer side of the envelope horizontal.

1.2.3.4 Index Card

- Size:
 - A6 Index card: [Width 105 mm (4.1") x Length 148 mm (5.8")]
 - 5 x 8" Index card: [Width 127 mm (5.0") x Length 203 mm (8.0")]
 - 10 x 8" Index card:[Width 127 mm (5.0") x Length 203 mm (8.0")]
- Thickness: Less than 0.23 mm (0.0091")
- Paper Types: EPSON special media

1.2.3.5 Self Adhesive Sheets

- Size
 - A4: [Width 210 mm (8.3") x Length 297 mm (11.7")]
- Paper Types: EPSON special media

1.2.3.6 Photo Paper

- Size:
 - A4: [Width 210 mm (8.3") x Length 297 mm (11.7")]
 - Letter: [Width 216 mm (8.5") x Length 279 mm (11.0")]
 - 4 x 6": [Width 102 mm (4") x Length 152 mm (6")]
 - Panoramic: [Width 210 mm (8.3") x Length 594 mm (23.4")]
- Paper Types: EPSON special media

1.2.3.7 Photo Stickers

- Size:
 - A6 with 4 or 16 frames:
 - [Width 105 mm (4.1") x Length 148 mm (5.8")]
- Paper Types: EPSON special media

1.2.4 Printable Area

□ Cut Sheet

See Figure 1-3 and Table 1-8 for the printable area for cut sheets.

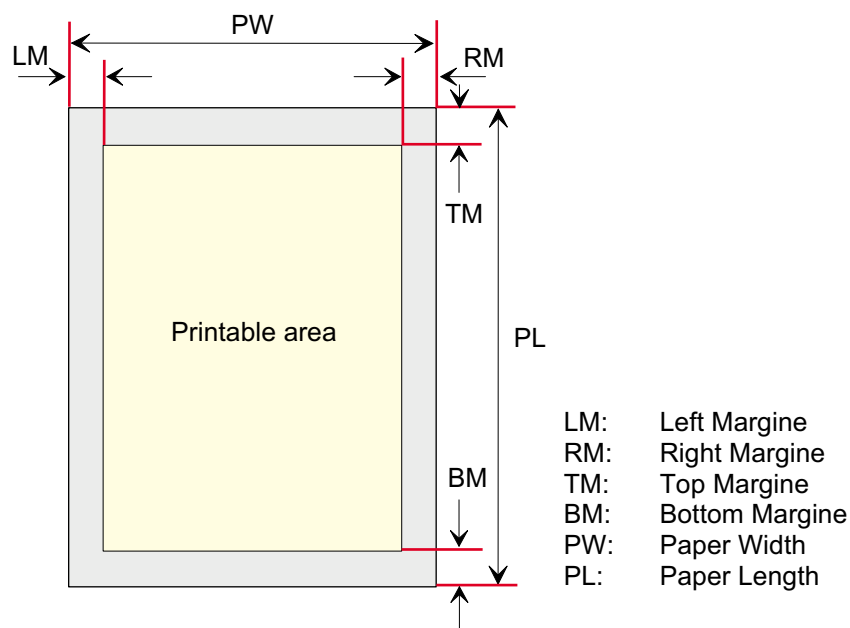

Figure 1-3. Printable Area for Cut Sheets

Table 1-8. Minimum margin for Raster Graphics Mode / Character Mode

Paper Size	Left Margin (Minimum)	Right Margin (Minimum)	Top Margin (Minimum)	Bottom Margin (Minimum)
A4	3 mm (0.12")	3 mm (0.12")	3 mm (0.12")	14 mm (0.54") 3 mm (0.12") *3
A5	3 mm (0.12")	3 mm (0.12")	3 mm (0.12")	14 mm (0.54") 3 mm (0.12") *3
Letter	3 mm (0.12")	3 mm (0.12")*1 9 mm (0.35")*2	3 mm (0.12")	14 mm (0.54") 3 mm (0.12") *3
B5	3 mm (0.12")	3 mm (0.12")	3 mm (0.12")	14 mm (0.54") 3 mm (0.12") *3
Legal	3 mm (0.12")	3 mm (0.12")*1 9 mm (0.35")*2	3 mm (0.12")	14 mm (0.54") 3 mm (0.12") *3
Half Letter	3 mm (0.12")	3 mm (0.12")	3 mm (0.12")	14 mm (0.54") 3 mm (0.12") *3
Executive	3 mm (0.12")	3 mm (0.12")	3 mm (0.12")	14 mm (0.54") 3 mm (0.12") *3

*1: For Raster Graphics mode

*2: For Character mode

*3: The minimum bottom margin is reduced to 3 mm when paper dimension is defined by using the command. Otherwise, the minimum bottom margin remains 14 mm. Note the extra printing area with the bottom margin of 3 mm is not a guaranteed area.

- Envelope See Table 1-9 and Figure 1-4 which show the minimum margin and printable area for envelopes, respectively.

Table 1-9. Minimum Margin for Envelopes

Paper Size	Left Margin (Minimum)	Right Margin (Minimum)	Top Margin (Minimum)	Bottom Margin (Minimum)
#10	3 mm (0.12")	28 mm (1.10")	3 mm (0.12")	14 mm (0.54")
DL	3 mm (0.12")	7 mm (0.28")	3 mm (0.12")	14 mm (0.54")
C6	3 mm (0.12")	3 mm (0.12")	3 mm (0.12")	14 mm (0.54")
5 x 8	3 mm (0.12")	7 mm (0.28")	3 mm (0.12")	14 mm (0.54")

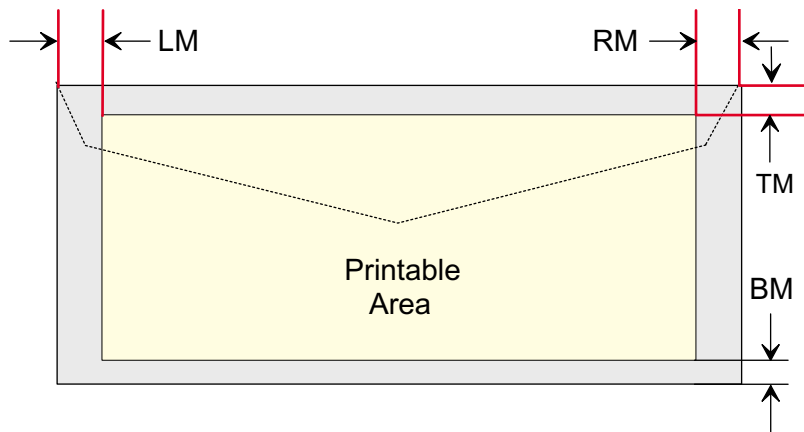

Figure 1-4. Printable Area for Envelopes

1.2.5 Ink Cartridge Specifications

1.2.5.1 Black Ink Cartridge

- Type: Exclusive ink cartridge
- Color: Black
- Print Capacity: 1200 pages / A4 (ISO/IEC 10561 Letter Pattern at 360 dpi)
- Ink life: 2 years from indicated production date
- Storage temperature:
 - Storage: -20°C ~ 40°C (within a month at 40 °C)
 - Packing storage: -30°C ~ 40°C (within a month at 40 °C)
 - Transit: -30°C ~ 60°C (within 120 hours at 60°C and within a month at 40°C)
- Dimensions: 28.9 mm (W) x 67.4 mm (D) x 41.8 mm (H)

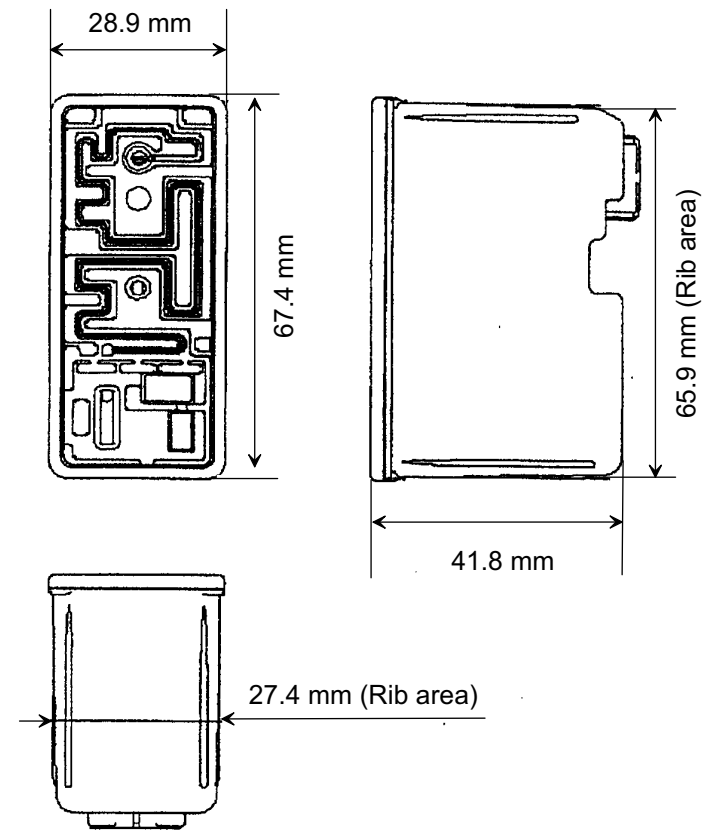

Figure 1-5. Black Ink Cartridge Appearance

1.2.5.2 Color Ink Cartridge

- Type: Exclusive ink cartridge
- Color: Magenta, Cyan, Yellow
- Print Capacity: 530 pages / A4 (at 360 dpi, 5% duty each color)
- Ink life: 2 years from indicated production date
- Storage temperature:
 - Storage: -20°C ~ 40°C (within a month at 40 °C)
 - Packing storage: -30°C ~ 40°C (within a month at 40 °C)
 - Transit: -30°C ~ 60°C (within 120 hours at 60°C and within a month at 40°C)
- Dimensions: 54.0 mm (W) x 67.4 mm (D) x 41.8 mm (H)

NOTES

1. Do not refill the cartridge. It is a consumable item.
2. Do not use the ink cartridge whose ink life has expired.
3. Ink will be frozen below -4 °C. To use ink that is frozen, let it defrost for at least 3 hours at room temperature.

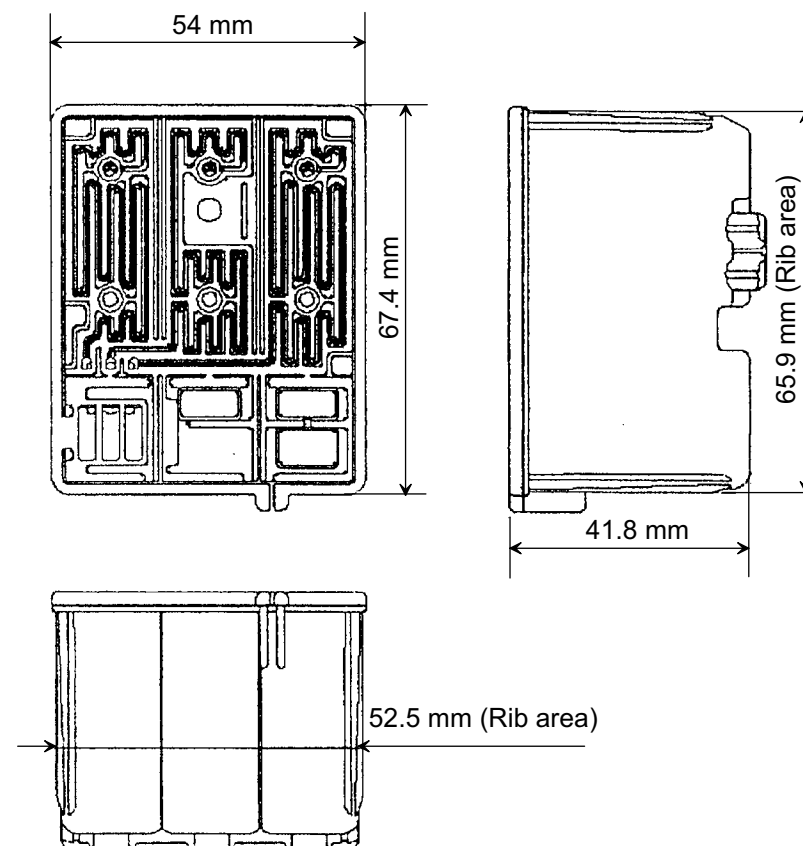

Figure 1-6. Color Ink Cartridge

1.2.6 Electrical Specifications

[120V version]

- Rated voltage: AC120V
- Input voltage range: AC99 ~132V
- Rated frequency range: 50 ~ 60 Hz
- Input frequency range: 49.5 ~ 60.5 Hz
- Rated current: 0.7A (Maximum 1.0A)
- Power consumption: Approx.30W (ISO/IEC 10561 Letter pattern)
Energy Star compliant
- Insulation Resistance: 10 M ohms min.
(between AC line and chassis, DC 500 V)
- Dielectric strength: AC1000 V rms. 1 minute or AC1200 Vrms.
1 second (between AC line and chassis)

[220~240V version]

- Rated voltage: AC220V ~ 240V
- Input voltage range: AC198 ~ 264V
- Rated frequency range: 50 ~ 60Hz
- Input frequency range: 49.5 ~ 60.5Hz
- Rated current: 0.4A (Maximum 0.5A)
- Power consumption: Approx.30W (ISO/IEC 10561 Letter pattern)
Energy Star compliant
- Insulation Resistance: 10M ohms min.
(between AC line and chassis, DC500V)
- Dielectric strength: AC1500 V rms.
1 minute (between AC line and chassis)

1.2.7 Environmental Condition

- Temperature: Operating = 10 to 35 °C (See Figure 1-7.)
Non-operating = -20 to 60 °C *1
1 month at 40 °C
120 hours at 60 °C
- Humidity: Operating = 20% ~ 80% RH *1
(See Figure 1-7.)
Non-operating = 5% ~ 85% RH *1 *2

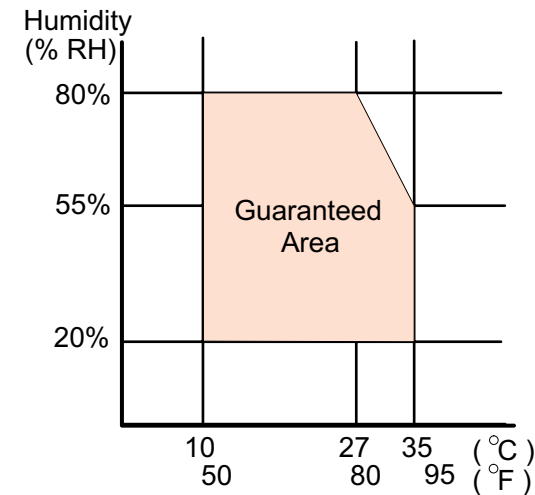

Figure 1-7. Temperature / Humidity of Range

- Resistance to shock: Operating = 1G, within 1 ms
Non-operating = 2G, within 2 ms *1
- Resistance to vibration: Operating = 0.15G (Operating)
Non-operating = 0.50G *1

*1: With a shipment container

*2: Without condensation

1.2.8 Reliability

- Total print volume: 75,000 pages (A4, Letter)
- Printhead life: 4000 million dots/nozzle

1.2.9 Safety Approvals

[120V version]

- Safety standard: UL1950
CSA22.2 No.950
- EMI: FCC part 15 subpart B class B
CSA C108.8 class B

[220~240V version]

- Safety standard: EN 60950 (VDE)
- EMI: EN55022 (CISPR Pub.22) class B
AS/NZS 3548 class B

1.2.10 Acoustic Noise

- Level: Approximately 47 dB (A) (According to ISO 7779)

1.2.11 CE Marking (220 ~ 240 V version)

- Low Voltage Directive 73/23/EEC: EN60950
- EMC Directive 89/336/EEC: EN55022 Class B
EN61000-3-2
EN61000-3-3
EN50082-1
IEC801-2
IEC801-3
IEC801-4

1.2.12 Physical Specifications

- Weight: 8.4 Kg
- Dimensions: 467 mm (W) x 296 mm (D) x 325 mm (H)

1.3 Interface

The EPSON Stylus Color 980 is equipped with USB, Bi-directional 8-bit parallel interface and a card slot for an optional Type-B interface.

1.3.1 Parallel Interface (Forward Channel)

- Transmission mode: 8 bit parallel, IEEE-1284 compatibility mode
- Synchronization: By /STROBE pulse
- Handshaking: BY BUSY and /ACKLG signal
- Signal level: TTL compatible level
- Adaptable connector: 57-30360 (amphenol) or equivalent

The BUSY signal is set high before setting either /ERROR low or PE high, and held high until all these signals return to their inactive state.

The BUSY signal is HIGH:

- During data entry (see Data transmission timing)
- When the input data buffer is full
- During /INIT signal is at LOW level or during hardware initialization.
- During a printer error condition (See /ERROR signal).
- When the parallel interface is not selected.

The ERROR signal is LOW when one of the following error has occurred:

- Printer hardware error (fatal error)
- Paper Out error
- Paper Jam error
- Ink Out error

The PE signal is at a high level during Paper Out error.

See Figure 1-8 and Table 1-10 which show the data transmission timing.

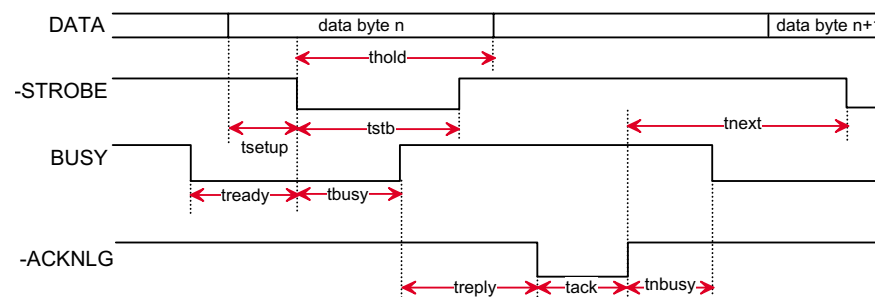

Figure 1-8. Data Transmission Timing

Table 1-10. Data Transmission Timing

Parameter	Minimum	Maximum
tsetup	500ns	---
thold	500ns	---
tstb	500ns	---
tready	0	---
tbusy	---	500ns
tt-out*	---	120ns
tt-in**	---	200ns
treply	0	---
tack	500ns	10us
tnbusy	0	---
tnext	0	---

NOTE: *tt-out* shows the rise and fall time of every output signal.
tt-in shows the rise and fall time of every input signal.
 Typical time of *tack* is shown in Table 1-11.

Table 1-11. Typical Time of Tack

Parallel Interface Mode	Typical Time of Tack
High speed	1 us
Normal speed	3 us

Table 1-12. Signal level for TTL Compatible (IEEE-1284 level 1 device)

Parameters	Minimum	Maximum	Condition
VOH*	---	5.5V	
VOL*	-0.5V	---	
IOH*	---	0.32mA	VOH = 2.4V
IOL	---	12mA	VOL = 0.4V
CO	---	50pF	
VIH	---	2.0V	
VIL	0.8V	---	
IiH	---	0.32mA	VIH = 2.0V
IiL	---	12mA	VIL = 0.8V
CI	---	50pF	

* A LOW logic level on the Logic H signal is as follows:
 2.0 V or less when the printer is turned off.
 3.0 V or more when the printer is turned on.
 The receiver provides an impedance equivalent to 7.5 K Ω to ground.

See Table 1-13 which shows the connector pin assignment and signals for the forward channel of the parallel interface.

Table 1-13. Parallel I/F Forward Channel

Pin No.	Signal Name	Return GND Pin	In/Out	Functional Description
1	/STROBE	19	I	The strobe pulse. Read-in of data is performed at the falling edge of this pulse.
2	DATA0	20	I	The DATA0 through DATA7 signals represent data bits 0 to 7, respectively. Each signal is at high level when data is logical 1 and low level when data is logical 0.
3	DATA1	21		
4	DATA2	22		
5	DATA3	23		
6	DATA4	24		
7	DATA5	25		
8	DATA6	26		
9	DATA7	27		
10	/ACKNLG	28	O	This signal is a negative pulse indicating that the printer can again accept data.
11	BUSY	29	O	A high signal indicates that the printer cannot receive data.
12	PE	28	O	A high signal indicates paper-out error.
13	SLCT	28	O	Always at high level when the printer is powered on.
14	/AFXT	30	I	Not used.
31	/INIT	30	I	The falling edge of a negative pulse or a low signal on this line causes the printer to initialize. Minimum 50 us pulse is necessary.
32	/ERROR	29	O	A low signal indicates printer error condition.
36	/SLIN	30	I	Not used.
18	Logic H	----	O	Pulled up to +5V via 3.9K ohm resistor.
35	+5V	----	O	Pulled up to +5V via 3.9K ohm resistor.
17	Chassis GND	----	---	Chassis GND.
16,33, 19-30	GND	----	---	Signal GND.
15,34	NC	----	---	Not connected.

*: In and Out refers to the direction of the signal as viewed from the printer.

1.3.2 Parallel Interface (Reverse Channel)

- Transmission mode: IEEE-1284 nibble mode
- Adaptable connector: See the forward channel.
- Synchronization: Refer to the IEEE-1284 specification
- Handshaking: Refer to the IEEE-1284 specification
- Data trans. timing: Refer to the IEEE-1284 specification
- Signal level: IEEE-1284 level 1 device
(See forward channel.)

- Extensibility request:

The printer responds affirmatively when the extensibility request values are 00H or 04H, as follows;

00H:Request Nibble Mode Reverse Channel Transfer.

04H:Request device ID using Nibble Mode Rev Channel Transfer.

- Device ID:

The printer sends following device ID string upon request.

When IEEE1284.4 is enabled;

[00H] [60H]

MFG:EPSON;

CMD:ESCPL2,PRPXL,BDC,D4;

MDL:Stylus[SP]COLOR[SP]980;

CLS:PRINTER;

DES:EPSON[SP]Stylus[SP]COLOR[SP]980;

When IEEE1284.4 is disabled;

[00H] [5DH]

MFG:EPSON;

CMD:ESCPL2,PRPXL,BDC;

MDL:Stylus[SP]COLOR[SP]980;

CLS:PRINTER;

DES:EPSON[SP]Stylus[SP]COLOR[SP]980;

NOTES:

1. [00H] denotes a hexadecimal value of zero.
2. MDL value and DES value depend on the EEPROM setting.
3. CMD value depends on the IEEE1284.4 setting.

See Table 1-14 which shows pin assignment for reverse channel

Table 1-14. Pin Assignment For Reverse Channel

Pin No.	Signal Name	Return GND Pin	In/Out	Functional Description
1	HostClk	19	I	Host clock signal.
2-9	Data0-7	20-27	I	The DATA0 through DATA7 signals represent data bits 0 to7, respectively. Each signal is at high level when data is logical 1 and low level when data is logical 0. These signals are used to transfer the 1284 extensibility request values to the printer.
10	PrtClk	28	O	Printer clock signal.
11	PtrBusy, Data Bit-3,7	29	O	Printer busy signal and reverse channel transfer data bit 3 or 7.
12	AckData Req, DataBit-2,6	28	O	Acknowledge data request signal and reverse channel transfer data bit 2 or 6.
13	Xflag, DataBit-1,5	28	O	X-flag signal and reverse channel transfer data bit 1 or 5.
14	HostBusy	30	I	Host busy signal.
31	/INIT	30	I	Not used.
32	/DataAvail, DataBit-0,4	29	O	Data available signal and reverse channel transfer data bit 0 or 4.
36	1284-Active	30	I	1284 Active Signal
18	Logic-H	----	O	Pulled up to +5V via 3.9K ohm resister.
35	+5V	----	O	Pulled up to +5V via 3.3K ohm resister.
17	Chassis GND	----	---	Chassis GND.
16,33, 19-30	GND	----	---	Signal GND.
15,34	NC	----	---	Not connected.

* In/Out refers to the direction of signal flow from the printer's point of view.

1.3.3 USB Interface

- Standard: Based on the following:
Universal Serial Bus Specifications Rev. 1.0
Universal Serial Bus Device Class Definition for Printing Device Version 1.0
- Bit Rate: 12 M bps
- Data Encoding: NRZI
- Adaptable Connector: USB Series B
- Recommended Cable Length: 2 meters

Table 1-15. Pin Assignment and Signal of the USB I/F

Pin No.	Signal Name	I/O	Description
1	Vcc	----	Cable power, Maxi. power consumption is 100 mA
2	-Data	Bi-D	Data
3	+Data	Bi-D	Data, pull up to +3.3 V via 1.5 K ohms resistor
4	Ground	----	Cable Ground

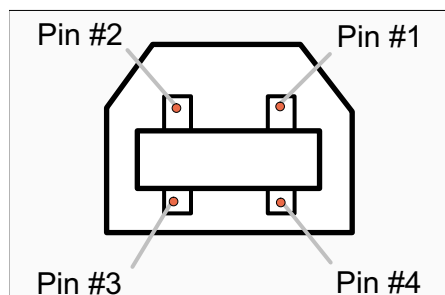

Figure 1-9. USB Pin Assignment

1.3.4 Optional interface

Type-B level 2 optional interfaces are available.

- Reply message:
ESC/P2 is selected
Min-Type: MTP48p, PW80 cl 10 cpi, PRG (Wxxxxx)rev, AP800ma, SPDO fast
Product-Name: Stylus COLOR 980
Emulation-Type: ESCPL2-00
Entity-Type: EPSONLQ2
X24E is selected
Main-Type: MTP48p, PW80cl10cpi, PRG(Wxxxxx)rev, AP800ma, SPDO fast
Product-Name: Stylus COLOR 980
Emulation-Type: PRPXL24-00
Entity-Type: EPSONPRPXL24
- Emergency command
0x00 :Get device ID
0x01 :Get all status
- Sending BDC-ST through DBIN register
When State-Reply is set "ON" by ST from Type-B I/F, sending BDC-ST through DBIN register is started. When State-Reply is started, "Start" and "End" of BDC-ST characters are announced by sending the Main command 0Eh.

See Table 1-16 which shows Reply for option command.

See Table 1-17 which shows Supported main command and sending timing

Table 1-16. Reply for Option Command

Option command number	Command name	Reply-A	Reply-B
00h	No-operation	None	None
01h	Start Hardware Reset	Accept	Execute OK
02h	Start Software Reset	Reject	None
03h	Send Main System Type	Accept	Execute OK
04h	Send Name Data	Reject	None
05h	Inquire Name Data	Accept	Execute OK
06h	Send Product Name	Accept	Execute OK
07h	Send Software Emulation Type	Accept	Execute OK
08h	Complete Buffered Data	Accept	Check Condition
09h	Stop Procedure	Reject	None
0Ah	Return Buffered Data	Reject	None
0Bh	Send Entity Type	Accept	Execute OK
0Ch	Send Status	Accept	Execute OK
0Dh	Quit Procedure	Reject	None
0Eh	Inquire ASCII Message	Reject	None
0Fh	Send ASCII Message	Accept	Execute OK
10h - 13h	(Reserved)	Unknown	None
14h	Inquire Emergency Message	Accept	Execute OK
15h	Send Emergency Message	Accept	Execute OK
16h - 1Fh	(Reserved)	Unknown	None
20h - FFh	(Reserved)	Unknown	None

Table 1-17. Supported main command and sending timing

Main command number	Command name	Sending timing
01h	Start Software Reset	<ul style="list-style-type: none"> ■ -INIT signal on the std. parallel I/F ■ Type-B I/F option command : 01h ■ Cold start
02h	Send Option Type	<ul style="list-style-type: none"> ■ Deciding the level of Type-B I/F after powered on
04h	Send Name Data	<ul style="list-style-type: none"> ■ Type-B I/F option command : 05h
07h	Inquire Software Emulation Name	<ul style="list-style-type: none"> ■ Changing Software Emulation Type
0Eh	Inquire ASCII Message	<ul style="list-style-type: none"> ■ Writing to DBIN register
14h	Inquire Emergency Reply	<ul style="list-style-type: none"> ■ Reply for Emergency command
15h	Send Emergency Message	<ul style="list-style-type: none"> ■ Receive Emergency command

1.3.5 Printer Language and Emulation

Printer language: ESC/P2
 IBM X24E emulation
 EPSON Remote

1.3.6 Prevention Hosts from Data Transfer time-out

Generally, hosts abandon data transfer to peripherals when a peripheral is in the busy state for dozens of seconds continuously. To prevent hosts from this kind of time-out, the printer receives data very slowly, several bytes per minute, even if the printer is in busy state. This slowdown is started when the rest of the input buffer becomes several hundreds of bytes. Finally, the printer is in the busy state continuously when the input buffer is full.

USB and IEEE1284.4 on the parallel interface do not require this function.

1.3.7 Auto Interface Selection

The EPSON Stylus Color 980 has three types of interfaces: USB, parallel interface and optional Type-B interface. Each interface can be selected manually in default setting mode or automatically.

Manual Selection:

One of three interfaces can be selected in default setting mode.

Automatic Selection:

The automatic interface selection is enabled by the default setting mode. In this automatic interface selection mode, the printer is initialized to the idle state scanning for which interface is to receive data when it is powered on. The interface that receives data first is selected. When the host stops data transfer and the printer is in the stand-by state for a number of seconds, the printer returns to the idle state. As long as the host sends data or the printer interface is busy state, the selected interface is let as it is. The changes to other interface are prohibited during duplex printing.

Interface state and interface selection

- When the parallel interface is not selected, the interface goes into the BUSY state.

NOTE: An interrupt signal, such as /INIT, on the parallel interface is not effective while that interface is not selected.

1.3.7.1 IEEE 1284.4 Protocol

The packet protocol described by IEEE1284.4 standard allows a device to carry on multiple exchanges or conversations which contain data and/or control information with another device at the same time across a single point-to-point link. The protocol is not, however, a device control language. It does provide basic transport-level flow control and multiplexing services. The multiplexed logical channels are independent of each other and blocking of one has no effect on the others. The protocol operates over IEEE1284.

- Automatic selection:
An initial state is compatible interface and starts IEEE1284.4 communication when magic strings (1284.4 synchronous commands) are received.
- ON:
IEEE1284.4 is enabled as initial state. Data sent before the magic string (1284.4 synchronous commands) is discarded.
- OFF:
IEEE1284.4 is disabled and IEEE1284.4 synchronous commands are ignored. Compatible interface is the initial state.

1.4 Control Panel Operation

The control panel of the EPSON Stylus Color 980 is composed of the 2 non-lock type push-buttons, 1 lock-type push-button, and 4 LEDs, as shown below:

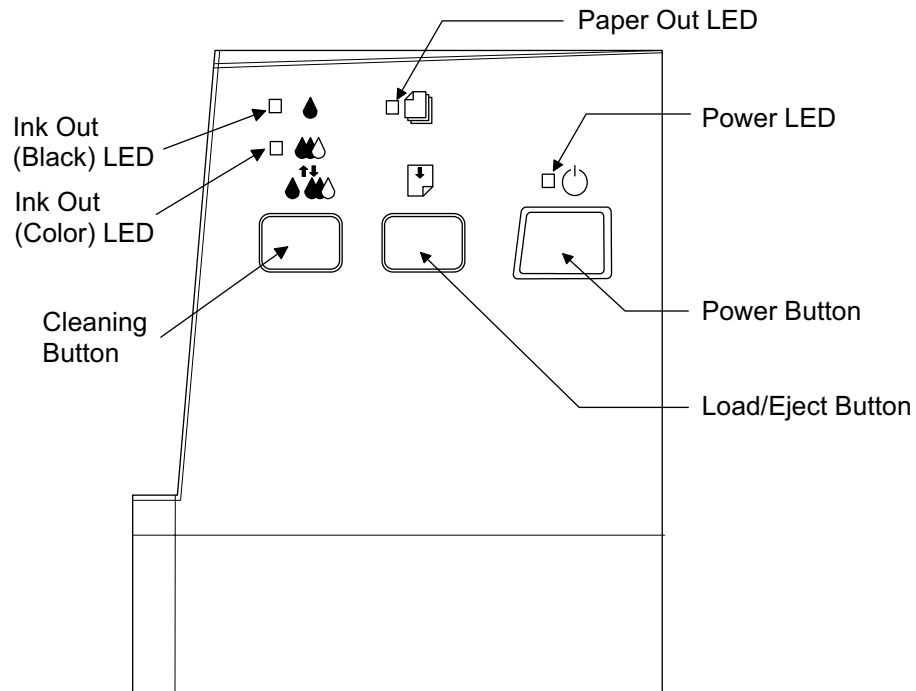

Figure 1-10. Control Panel

1.4.1 Indicators (LEDs)

1. Power
Lights when the operate switch is "ON", and AC power is supplied.
2. Paper out
Lights during the paper-out condition, and blinks during the paper-jam condition.
3. Ink Out (Black)
Lights during no Black ink condition, and blinks during the Black ink low condition.
4. Ink Out (Color)
Lights during no Color ink condition, and blinks during the Color ink low condition.

1.4.2 Panel Functions

- Panel function: Refer to Table 1-18.

Table 1-18. Panel Functions

Button	Function
Load/Eject (within 2 seconds) *1	<ul style="list-style-type: none"> • Loads or ejects paper. • When the carriage is in the I/C replacement position, pressing this button returns the carriage to the capping position. • In the condition of “Double Feed Error” returning from error condition printing is restarted
Load/Eject (for 2 seconds) *1	<ul style="list-style-type: none"> • Starts the I/C replacement sequence. *2 • Move the carriage to the I/C replacement position.
Cleaning (for 2 seconds) *1	<ul style="list-style-type: none"> • Starts the printhead cleaning sequence. • Starts the I/C replacement sequence when the printer is in one of the following conditions: “Ink Low”, “Ink Out”, No Ink Cartridge” *2
Cleaning (within 2 seconds) *1	<ul style="list-style-type: none"> • When the carriage is in the I/C replacement position, returns the carriage to the capping position.

*1: 3 seconds is specified in the Users Guide.

*2: This operation is not effective in printing status.

- Panel function with power on: Refer to Table 1-19.

Table 1-19. Panel Function with Power On

Button	Function
Load/Eject	1) Starts the status print. *1
Cleaning	Enters the printer setting mode. (The Paper Out LED starts blinking.) *2 Specified button must be then pressed while the LED is blinking to activate each mode. (See Section 1.4.2.1.)
Load/Eject + Cleaning	Enters the special setting mode. (Factory use only) Specified button must be then pressed while the Paper Out LED is blinking to activate each mode. (See Section 1.4.2.2.)

*1: The status print includes firmware version, ink counter, and nozzle check pattern.

1.4.2.1 Printer Setting Mode

While turning the printer on, press the Cleaning button, and the Paper Out LED starts blinking. This operation must be followed by pressing the specified button while the Paper Out LED is still blinking to enter the Default setting mode or Printhead alignment mode, as described in Table 1-20.

Table 1-20. Printer Setting Mode

Button	Function / Operation
Cleaning or no button	While the Paper Out LED is blinking, pressing the Cleaning or no button generates the Default setting mode. *1
Load/Eject (Press it within 10 seconds.)	While the Paper Out LED is blinking, pressing the Load/Eject button generates the Printhead alignment mode.
Load/Eject (Hold it down for 10 seconds.)	Changes the default for the parallel I/F communication protocol. *2

*1: Leaving the Paper Out LED blinking without pressing any button also generates the Default setting mode.

*2: Not intended for users. This function is used only for troubleshooting.

See the following pages for detailed information on the default setting mode and the Printhead alignment mode.

- Default setting mode
Some printer setting parameters can be changed by users and will be referred at the time of printer initialization. The setting method is as shown below:

1. Enter the Default setting mode.
2. Select the desirable language for “Usage of this mode” by pressing the Cleaning button.
3. Press Load/Eject button. The current setting and the “Usage of this mode” in the selected language is printed.
4. Select the menu by pressing the Cleaning button.
5. Press the Load/Eject button to enter the value selection phase of the selected menu.
6. Select the value by pressing the Load/Eject button.
7. Press the Cleaning button. The printer memorizes the selected setting value, and returns the indication to the main menu.
8. Repeat the steps from 4 to 7. The menu selection will return to the first menu after the last menu selection is over.
9. Turn the printer off. The new settings are stored in the non-volatile memory.

Table 1-21. Default Setting Menu

Menu	Setting
Font	Roman, Sans Serif, <u>Courier</u> , Prestige, Script, Roman T, Sans Serif H, Draft
Pitch	<u>10 cpi</u> , 12 cpi, 15 cpi, 17.1 cpi, 20 cpi, Proportional
Print direction	<u>Auto</u> , Bi-D, Uni-D
Loading Position	3 mm, <u>8.5 mm</u> , Others

Table 1-22. Default Setting Menu (continued)

Menu	Setting																								
I/F mode	<u>Auto</u> , Parallel, USB, Optional																								
Auto I/F wait mode	<u>10 seconds</u> , 30 seconds																								
Network I/F mode	This mode is for the network environment only. <u>Off</u> : Used in a usual environment. On: Used in the network environment.																								
Parallel I/F transfer rate	<u>Fast</u> , Normal																								
Software	<u>ESC/P2</u> , IBM X24E																								
Auto CR (IBM mode only)	On, <u>Off</u>																								
A.G.M (IBM mode only)	On, <u>Off</u>																								
Auto line feed	On, <u>Off</u>																								
0 slash	<u>0</u> , \emptyset																								
Character tables <Standard version>	<table border="0"> <tr> <td>Italic USA</td> <td>Italic France</td> <td>Italic Germany</td> </tr> <tr> <td>Italic UK</td> <td>Italic Denmark</td> <td>Italic Sweden</td> </tr> <tr> <td>Italic Italy</td> <td>Italic spain 1</td> <td><u>PC 437</u></td> </tr> <tr> <td>PC 850</td> <td>PC 860</td> <td>PC 863</td> </tr> <tr> <td>PC865</td> <td>PC 861</td> <td>BRASCII</td> </tr> <tr> <td>Abicomp</td> <td>Roman 8</td> <td>ISO Latin 1</td> </tr> <tr> <td>PC 858</td> <td>ISO 8859-15</td> <td></td> </tr> </table>	Italic USA	Italic France	Italic Germany	Italic UK	Italic Denmark	Italic Sweden	Italic Italy	Italic spain 1	<u>PC 437</u>	PC 850	PC 860	PC 863	PC865	PC 861	BRASCII	Abicomp	Roman 8	ISO Latin 1	PC 858	ISO 8859-15				
Italic USA	Italic France	Italic Germany																							
Italic UK	Italic Denmark	Italic Sweden																							
Italic Italy	Italic spain 1	<u>PC 437</u>																							
PC 850	PC 860	PC 863																							
PC865	PC 861	BRASCII																							
Abicomp	Roman 8	ISO Latin 1																							
PC 858	ISO 8859-15																								
Character tables <NLSP version >	In addition to the Standard version: <table border="0"> <tr> <td>PC437 Greek</td> <td>PC 853</td> <td>PC 855</td> </tr> <tr> <td>PC852</td> <td>PC 857</td> <td>PC 866</td> </tr> <tr> <td>PC869</td> <td>MAZOWIA</td> <td>Code MJK</td> </tr> <tr> <td>ISO 8859-7</td> <td>ISO Latin 1T</td> <td>Bulgaria</td> </tr> <tr> <td>PC 774</td> <td>Estonia</td> <td>ISO 8859-2</td> </tr> <tr> <td>PC 866 LAT</td> <td>PC 866 UKR</td> <td>PC APTEC</td> </tr> <tr> <td>PC 708</td> <td>PC 720</td> <td>PC AR864</td> </tr> <tr> <td><u>PC 437</u></td> <td></td> <td></td> </tr> </table>	PC437 Greek	PC 853	PC 855	PC852	PC 857	PC 866	PC869	MAZOWIA	Code MJK	ISO 8859-7	ISO Latin 1T	Bulgaria	PC 774	Estonia	ISO 8859-2	PC 866 LAT	PC 866 UKR	PC APTEC	PC 708	PC 720	PC AR864	<u>PC 437</u>		
PC437 Greek	PC 853	PC 855																							
PC852	PC 857	PC 866																							
PC869	MAZOWIA	Code MJK																							
ISO 8859-7	ISO Latin 1T	Bulgaria																							
PC 774	Estonia	ISO 8859-2																							
PC 866 LAT	PC 866 UKR	PC APTEC																							
PC 708	PC 720	PC AR864																							
<u>PC 437</u>																									

*: Underlined values are the defaults for the EEPROM reset.

- Printhead alignment mode

Alignment method is as described below:

1. While holding down both Load/Eject and Cleaning (Black) buttons, turn the printer on.
2. Printer prints an instruction sheet that shows how to adjust the printer and current alignment.
3. Referring to the current alignment, press the Cleaning button until the LED indicate the appropriate test number.
4. Press the Load/Eject button. The printer prints the test pattern.
5. Referring to the test patterns on the new printout, select the most closely aligned pattern by pressing the Load/Eject button.
6. Press the Cleaning button.
7. Repeat the steps from 3 to 6 until all test patterns are properly aligned.
8. Turn the printer off.

1.4.2.2 Special Setting Mode

While turning the printer on, pressing the both Load/Eject and Cleaning buttons generates the Special setting mode. While the Paper Out LED is blinking, activate each function by pressing the specified button(s) in the method described in Table 1-23.

Table 1-23. Special Setting Mode

Switch	Function
Load/Eject	While the Paper Out LED is blinking, pressing the Load/Eject button initializes the EEPROM and resets the timer IC. (Refer to EEPROM Address Map in Appendix.)
Cleaning (Hold it down for 10 seconds)	While the Paper Out LED is blinking, pressing the Cleaning button for 10 seconds resets the waste ink counter in the EEPROM. (Refer to EEPROM Address Map in Appendix.)

1.4.3 Printer Condition and Panel Status

Table 1-24 shows printer condition and panel status. Since the table shows various error status and also indicates printer status, it enables you to find appropriate repair ways.

Table 1-24. Printer Condition and Panel Status

Printer Status	Indicators				Priority
	Power	Ink Out (Black)	Ink Out (CMY)	Paper Out	
Power on condition	On	---	---	---	9
Ink Sequence mode	Blink	---	---	---	6
I/C replacement mode	Blink	---	---	---	5
Data processing	Blink	---	---	---	8
Paper Out	---	---	---	On	4
Double Feed	---	---	---	On	4
Paper Jam	---	Off	Off	Blink	3
No I/C, Ink Out (Black)	---	On	---	---	7
Ink level low (Black)	---	Blink	---	---	7
No I/C, Ink Out (CMY)	---	---	On	---	7
Ink level low (CMY)	---	---	Blink	---	7
Enters the EEPROM and Timer IC Reset	---	ON (for 1 second only)			---
Maintenance Request	Blink	Blink	Blink	Blink	2
Fatal Error	Blink	On	On	Blink	1

1.5 Error Status

When any of the following status occurs, the printer goes in the error status and stops receiving data, setting the /ERROR signal in the interface to “Low”, and Busy signal to “High”. During this condition, the printer is in non-printable status. Refer to Section 1.4.3 for detailed LED Panel indicator status and corresponding error types.

1.5.1 Ink Out

When the printer has run out the most of the ink of any color, it warns of Ink Low condition and keeps printing. When the printer runs out the whole ink of any color, it stops printing and indicates the Ink Out error. User is required to install a new ink-cartridge in this state. Note if an ink-cartridge has been taken out, it should never be used again. Reinstalling the used cartridge (not fully filled with ink) upsets the ink level detection and may cause a serious problem in the printhead as a result.



Never use an ink cartridge that has been removed.

1.5.2 Paper Out

When the printer fails to load a sheet, it goes into the Paper Out error condition.

1.5.3 Paper Jam

When the printer fails to eject a sheet, it goes into the Paper Jam error condition.

1.5.4 No Ink Cartridge

When the printer detects that the ink cartridge has come off, it goes into the No ink cartridge error.

1.5.5 Maintenance Request

When the total quantity of ink wasted through the cleanings and flushing has reached the limit, printer indicates this error and stops printing. The absorber in the printer needs to be replaced with a new one by a service person.

1.5.6 Fatal Errors

When the printer detects the carriage control error or CG access error, it enters the fatal error condition.

1.5.7 Double Feed Errors

When the printer fails to load a sheet, it goes Double feed error condition.

1.6 Printer Initialization

The EPSON Stylus Color 980 is equipped with three types of initialization methods.

□ Power-on initialization

The printer is initialized when it is turned on or recognizes the cold-reset command (remote RS command). When the printer is initialized, it performs the following:

- (a) Initializes the printer mechanism.
- (b) Clears the input data buffer.
- (c) Clears the print buffer.
- (d) Sets the default values.

□ Operator initialization

This printer is initialized when it is turned on again within 10 seconds after last power off or recognizes the /INIT signal (negative pulse) of the parallel interface. When printer is initialized, it performs the following:

- (a) Caps the printhead.
- (b) Ejects a paper.
- (c) Clears the input data buffer.
- (d) Clears the print buffer.
- (e) Sets the default values.

□ Software initialization

The ESC@ command also initializes the printer. When the printer is initialized, it performs the following:

- (a) Clears the print buffer.
- (b) Sets the default values.

1.7 Component Layout

The main components of the Stylus Color 980 are as follows:

- 1) Printer mechanism
- 2) C380 Main board
- 3) C265 PSB/PSE board
- 4) C265 panel board
- 5) C265 relay board

1.7.1 Printer Mechanism

The printer mechanism of the Stylus Color 980 has black and color heads united in one unit which drives larger amount of nozzles (180 nozzles in total) than ever. Also, for a new ink jet printer feature, the printer has succeeded in printing in the acceleration/deceleration areas by reading the slits on the linear scale to improve the throughput. This improvement in throughput mostly depends on the Pump/ASF switching mechanism. In other printers, the gear trains are switched when the trigger lever hits the mechanism along with the carriage's movement. In Stylus Color 980, however, the exclusive solenoid is directly attached to the mechanism instead. With the solenoid which switches drive at a higher speed, the printer can control high-speed paper ejection system: the printer bring the leading edge of the second sheet to the printing position just before ejecting the first sheet.

The motors equipped with the printer are CR motor, PF motor, and the Pump/ASF Motor, same as for the Stylus Color 900.

1.7.2 C380 Main Board

The main features of the C380 Main board are as follows.

1. IEEE1284 compliant
ECP mode is available
Type-B I/F is available
2. USB full-speed is available (at 12 M bps without the hub).
3. All motors (CR motor, Pump/ASF motor, and PF motor) are controlled with the micro step system (using up to 4W1-2 phase excitation mode) and current attenuation mode (First, Slow, Mixed, and Decay).
4. Intensive temperature control of the new type of the printhead: operates the cooling fan using the thermistors and the abnormal temperature detection circuit on the printhead board.

C90A09CA, a CPU which is the hub of the C380 Main board, has an internal flash memory with the size of 128 KB. Since the CPU runs with 24 MHz, it can send print data efficiently for a high throughput. The C380 Main board has two independent exclusive ASICs, ASIC1 and ASIC2. The former controls all interfaces but the USB I/F and sensors, while the latter controls the printhead, motors, encoder, and USB I/F. The combined IC (IC8) which has a normal timer IC and EERPOM in one chip also features the printer. Since the EEPROM counts ink consumption at the valuable printing ^{*1}, its size has increased to 2 K bit.

*1: The valuable dot system, or many-valued dot system, enables the printer to freely fire three different sizes of dots (normal, middle, and small dots) in one raster. In other printers, if the super micro dot mode is once selected through the printer driver, the printers prints only in the selected mode until the current print data is completed. However, the valuable dot system of this printer enables the printer

to fire three different sizes of dots in one raster, and ink-jet specific adverse conditions such as uneven printing and white banding are improved as a result.

The C380 Main board is also equipped with a CG-ROM which deals with DOS users. The CG ROM attachment condition and size are as shown in Table 1-25.

Table 1-25. Relation between P-ROM and CG ROM

Destination	P-ROM	CG-ROM
Standard version	16 M (TFU00X)	Not installed.
NLSP version	16 M (TFU00X)	16M (M160B16XA)

NOTE:The "X" in the table represents the version.

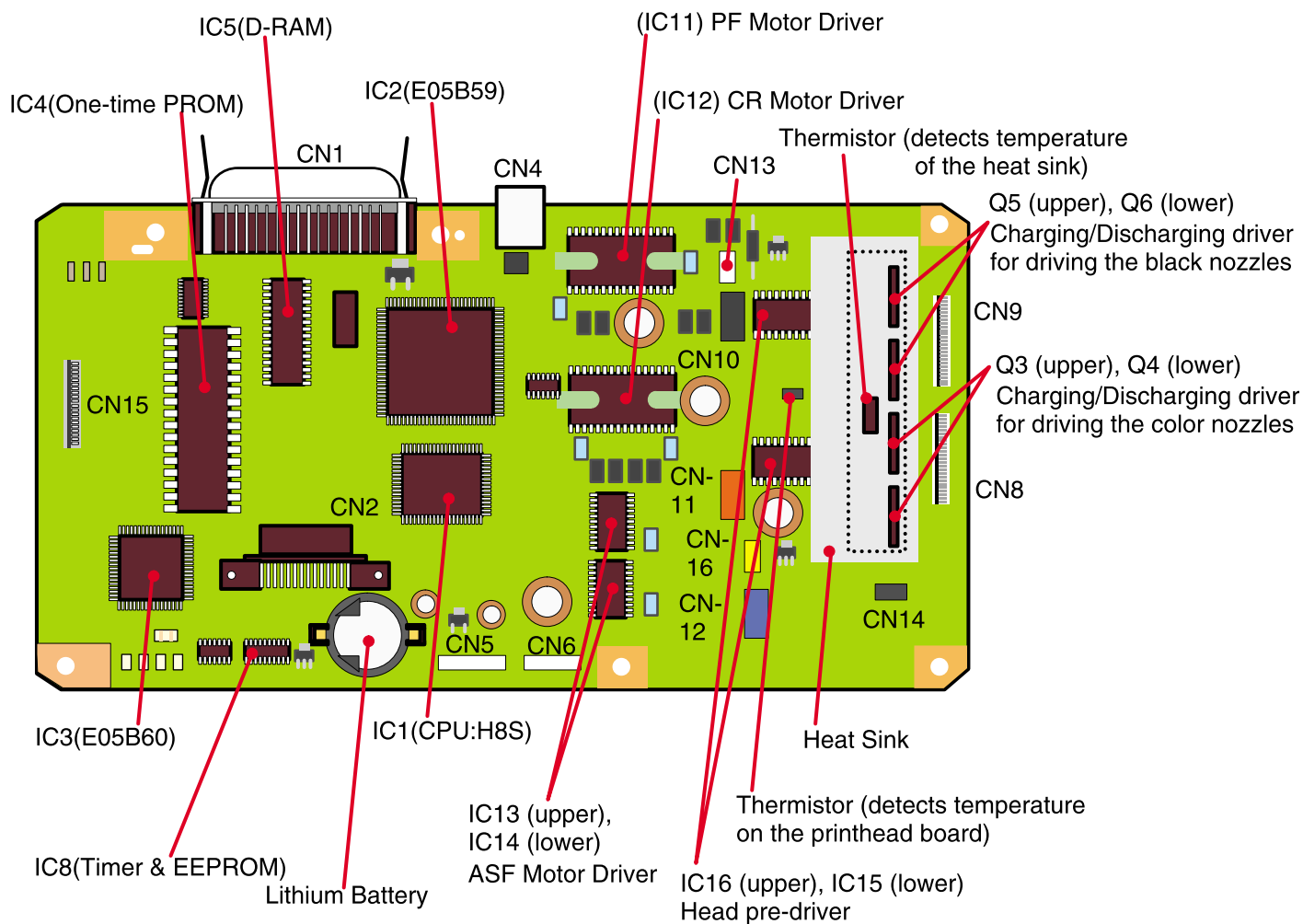

Figure 1-11. C380 Main Board

1.7.3 C265 PSB/PSE Board

There are two types of the C265 power supply board as listed below.

- C265 PSB board: For America, Japan, part of South east Asia
- C265 PSE board: The rest of all regions



Never touch the heat sink (radiation plate) on the Q1 with your bare hands as it is not insulated. Otherwise, you will get an electrical shock.

The C265 PSB/PSE board uses the switching regulator system. Since the C265 PSB/PSE board uses the power switch on the secondary side, it keeps applying voltage to the primary side across the T1. Especially, the heat sink to which the Q1 is attached can not be insulated due to the circuit's formation. Therefore, to avoid an electrical shock, be careful not to touch the heat sink and other metallic parts simultaneously while troubleshooting.

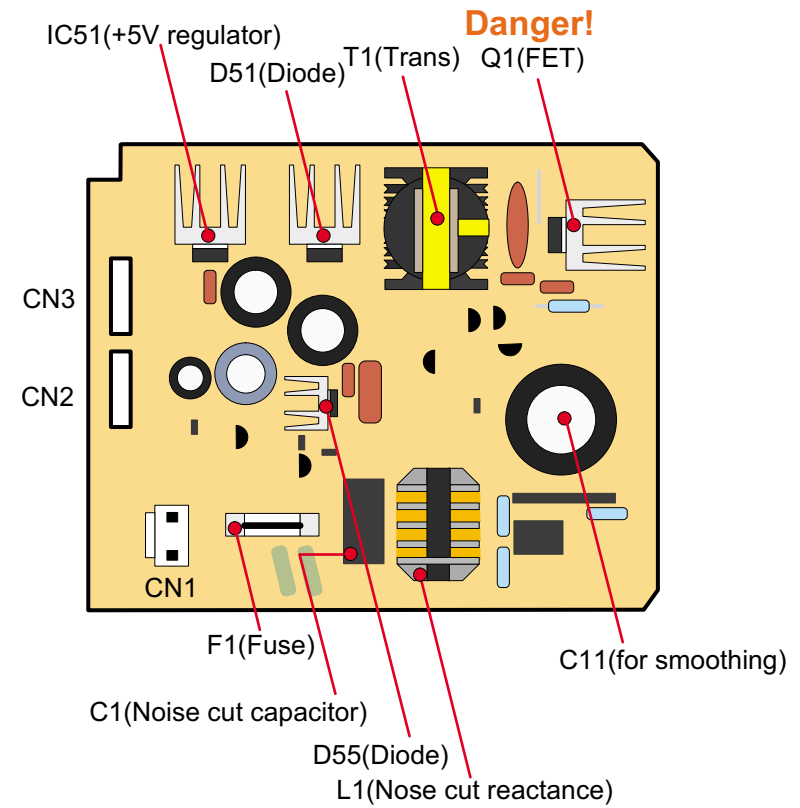

Figure 1-12. C265 PSB/PSE Board

1.7.4 C265 PNL Board

The C265 panel board is composed of the three switches and four LEDs.

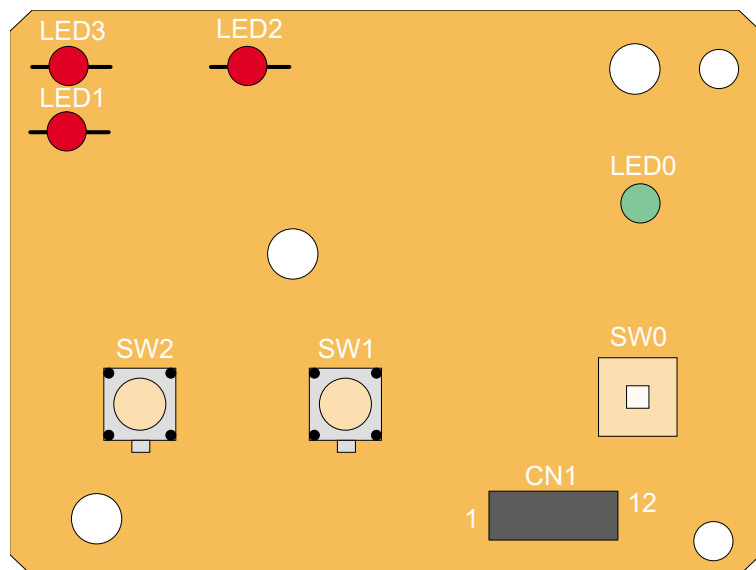

Figure 1-13. C265 PNL Board

1.7.5 C265 Relay Board

The C265 relay board is installed to relay the following with connectors:

- Power for driving motors and sensors
- Control signals

If any of the connectors is connected to a wrong position during assembly, the printer shows a fatal error at power on.

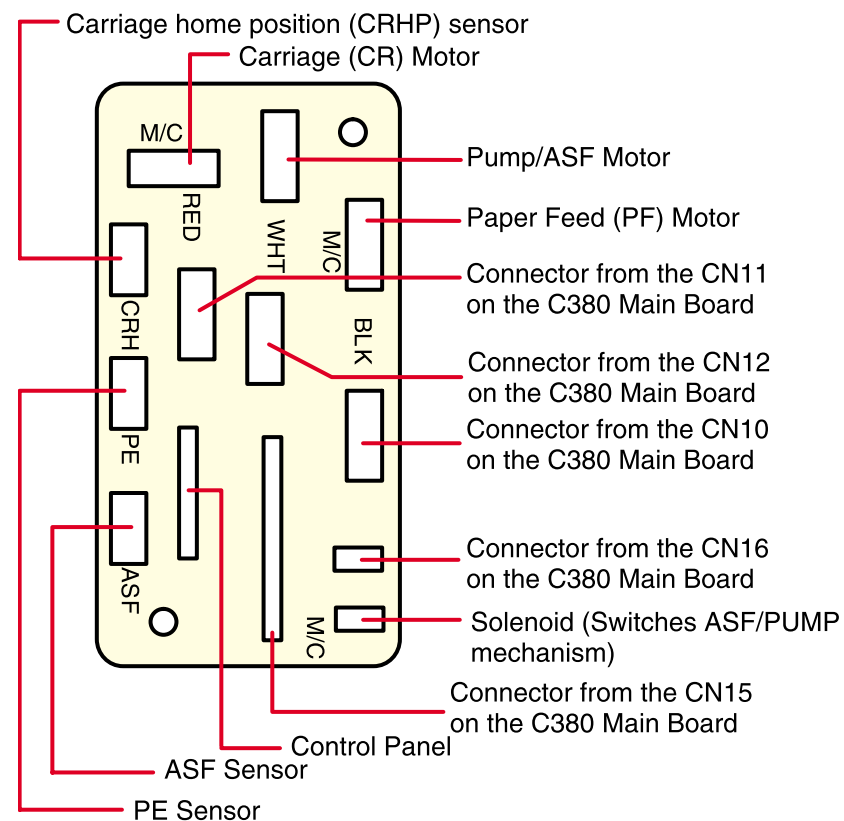

Figure 1-14. C265 Relay Board

CHAPTER

2

OPERATING PRINCIPLES

2.1 Overview

This chapter describes the operating principles of the printer mechanism and electrical circuits.

2.2 Printer Mechanism Operating Principles

The EPSON Stylus Color 980 has black and color heads united in one unit which includes a total of 480 nozzles: 192 nozzles for black (96 nozzles x 2) and 96 nozzles for each color. This printhead enables the printer to print 3 lines by one pass at 10-cpi printing. Also, new ASF/pump switching mechanism offers higher throughput with quick feeding motion at continuous printing by combining the trigger solenoid and independent pump/ASF motor. Production of PTS signal using the encoder belt also enables the printer to improve printing accuracy, detect paper jam in the CR operational range, and print during acceleration/deceleration (on normal paper / 360 x 360 dpi only).

See Figure 2-1 for the printer mechanism block diagram.

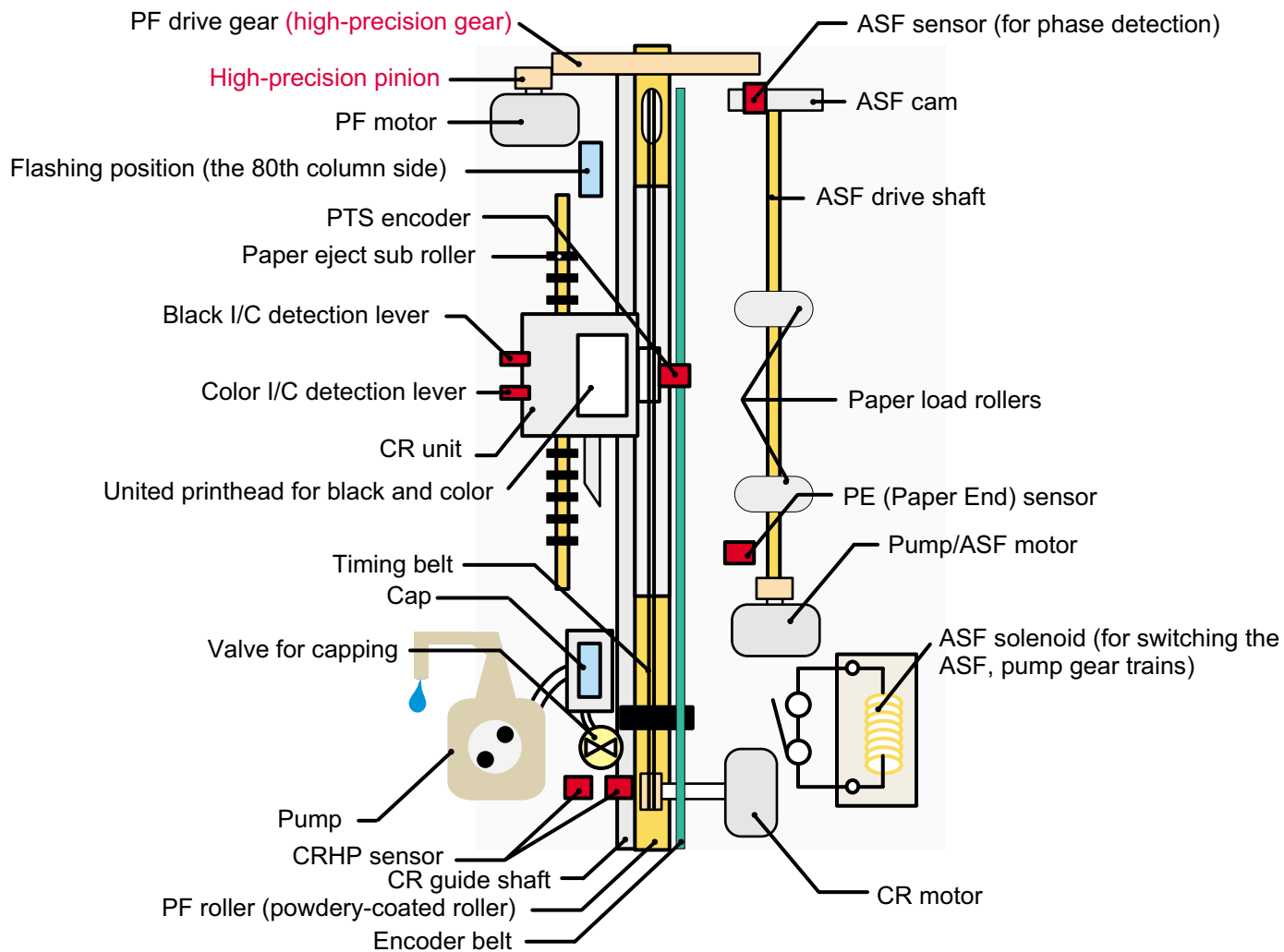

Figure 2-1. The Stylus Color 980 Printer Mechanism Block Diagram

2.2.1 Carriage Mechanism

As shown in Figure 2-1, the carriage unit with the printhead on it moves right and left, depending on the rotational direction of the CR (Carriage) motor. Table 2-1 shows the CR motor specifications.

Table 2-1. CR Motor Specifications

No.	Item	Specifications
1	Motor Type	4-phase / 200-pole / HB-type stepping motor
2	Drive voltage	42 VDC \pm 5% (Applied to the driver)
3	Coil resistance	5.8 Ω \pm 10%
4	Drive mode	Bipolar constant current drive

The CR unit position is always memorized and controlled by the CRHP (Carriage Home Position) sensor. This sensor confirms the CR position to renew the memory at the following timing:

- When power is turned on / off
- When a head cleaning operation, including initial ink charge, is performed.
- When the printer returns to a ready status because the printer has executed print job or receives no data for one second or more.

See Table 2-2 and Table 2-3 which show the CRHP sensor specifications and CRHP sensor switch mode, respectively.

Table 2-2. CRHP Sensor Specifications

No.	Item	Specifications
1	Type	Photo-electrically transfer system (SHARP GP1S73P2)
2	Drive voltage	5 V \pm 5%
3	Collector resistance	30 VDC or less

Table 2-3. CRHP Sensor Switch Mode

CR Position	Switch mode	Sensor output
Within the CRHP range	Open	0.7 VDC or less
Off the CRHP range	Close	2.4 VDC or more

If this sensor is defective or does not work, it does not detect the carriage while the carriage is in the home position seek mode. In this case, the printer cuts off electricity to the CR motor and shows a fatal error.

Like the Stylus color 900, the Stylus color 980 also uses a linear encoder to obtain secure carriage movement and accurate print timing. The linear encoder reads slits on the encoder belt (linear scale) above the timing belt to control the carriage. See Table 2-4 for the linear encoder specifications.

Table 2-4. Linear Encoder Specifications

No.	Item	Specifications
1	Type	Radiative Incremental encoder module
2	Drive voltage	5 VDC \pm 5%
3	Output waveform	Phase A/B 2-channel digital output (TTL level)
4	Minimum step	1/180 inch (increment of the lines on the linear scale)
5	Response frequency	20 KHz

The ASIC (IC2) reads the linear scale (increment: 1/180 inch) and internally divides data by 8. The read information is used to produce basic drive frequency for 2880-dpi trapezoidal waveform production. If the encoder is defective or in an undetectable condition, the printer generates a fatal error immediately after power on. This error occurs before the carriage's home position seeking operation.

Beside detecting the carriage position, the CRHP sensor also serves to determine whether or not the carriage is working properly. If the setting signals (pulses) sent from the encoder do not reach the specified level while the CR is moving in the acceleration / constant / deceleration modes in its operative range, the program consequently assumes that paper is jamming or the carriage is operating irregularly, and shows the paper jam error by bringing up the LEDs of the corresponding combination.

The printer is equipped with 2 accouters used to detect the ink cartridges in the carriage unit driven by the CR motor. The printer, however, is designed to operate the accouters only when both black and color ink cartridges are installed. See Table 2-5 and Table 2-6 for the ink cartridge sensor specifications and ink cartridge sensor switch mode, respectively.

Table 2-5. Ink Cartridge Sensor Specifications

No.	Item	Specifications
1	Detection type	Using a micro switch
2	Rated voltage	5 VDC \pm 5%
3	Rated current	10 mA
4	Contact resistance	50 m Ω

Table 2-6. Ink Cartridge Sensor Switch Mode

Cartridge	Sensor Status	Sensor Output
Absent	Open	2.4 VDC or more
Present	Closed	0.7 VDC or more

If the ink cartridge sensor is defective or in an undetectable condition, the printer shows No Ink Cartridge Error immediately after the printer is turned on.

2.2.2 Printing Mechanism

The printing mechanism of the printer is all included inside the printhead. The printing method is EPSON-exclusive MACH system, which is used in other EPSON ink jet printers, but the printhead is not compatible with any other printer. See Figure 2-2 for the printing mechanism block diagram.

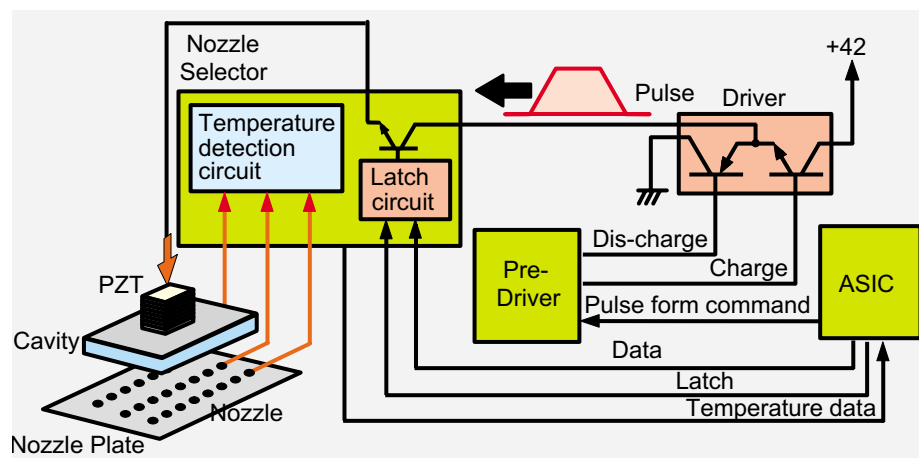

Figure 2-2. Printing Mechanism Block Diagram

The printing mechanism performs printing by applying voltage to the PZT (integrated piezoelectric element) inside the printhead. With the voltage applied to the PZT, the cavity, a tank filled with ink, is pressed by the PZT and ejects ink from nozzles as the result. Unlike to the illustration, the actual number of the PZT included in the printhead in this printer is 480, the same number as nozzles, and each PZT is independently driven.

The steps below describes how the printing mechanism works.

1. Head drive pulse form command signal is output from the ASIC after the printer is turned on.

2. Receiving the signal, the Pre-driver outputs the head drive pulse signal to the driver.
3. If no printing data is sent, pulse output from the driver is not applied to the PZT in the printhead: because the transistor on the nozzle selector is not on.
4. If any printing data is sent from a PC, 5 serial data (3 for Y, M, and C, and 2 for 2 rows of black) are sent to the nozzle selector from the ASIC. Each serial data consists of 96 data since each row is composed of 96 nozzles. When these data is all transferred, a Latch signal is output from the ASIC to the nozzle selector after specified period of time.
5. When the Latch signal is sent, a PZT signal is applied to the base side of the transistor via the latch circuit in the nozzle selector.
6. Head drive pulse constantly output from the driver is then applied to the PZT by the pulse output after a set of serial data and the latch signal are all transferred.
7. The PZT drive pulse radiates large heat since it is driven with the basic drive frequency of 32.4 K Hz and also has such a large amount of drive elements as 480 PZT. Therefore, the abnormal temperature detection circuit is included in the nozzle selector to detect temperature of each nozzle so that heat radiation stays under the maximum level. If the circuit detects abnormally high temperature in any nozzle row, the printer regards the condition as an accidental printing malfunction such as dot missing, and it automatically enters the cleaning CL2, the most powerful cleaning cycle. See the sensor descriptions in Chapter 2 for the operations after this cleaning. The printhead also has the thermistor in it to subtly change the voltage level of the drive pulse in accordance with the temperature condition in use.

[Nozzle configuration]

See Figure 2-3 for the nozzle configuration of the Stylus Color 980.

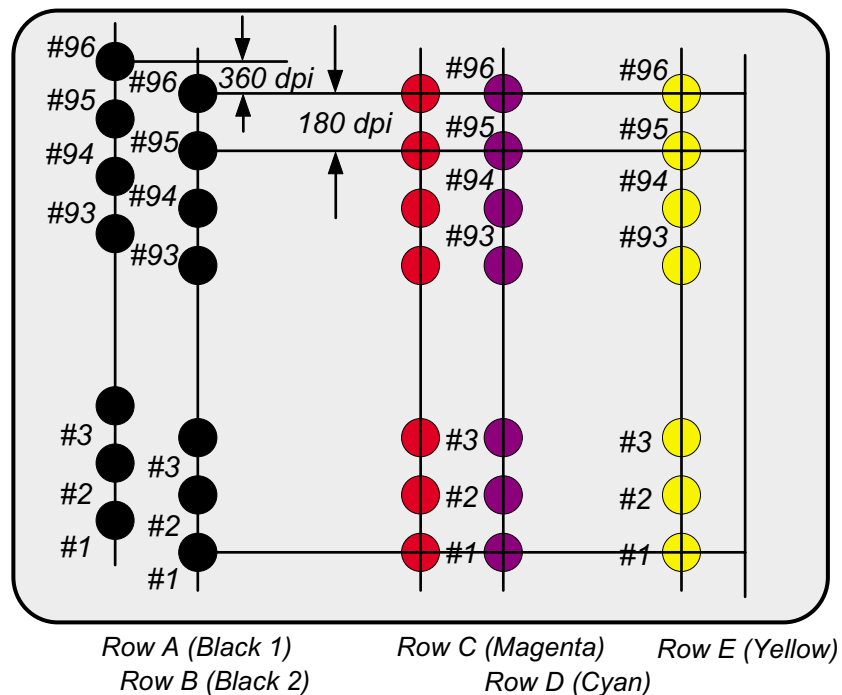

Figure 2-3. Nozzle Configuration

As shown in the figure, the black nozzles are aligned at 360 dpi (vertical) and the color nozzles are aligned at 180 dpi. In the color printing mode, only “B” row among 2 black nozzle rows is used and the other row “A” is not used. (The same mechanism is used for the microweave printing.)

2.2.3 Paper Load Mechanism

The paper load mechanism transports paper set in the hopper in the ASF into the printer. It is operated by the ASF and the pump/ASF motor which drive the ASF. The pump/ASF motor specifications are as shown in Table 2-7.

Table 2-7. Pump/ASF Motor Specifications

No.	Items	Specifications
1	Type	4-phase / 48-pole / PM-type stepping motor
2	Drive voltage	42 VDC ± 5% (Applied to the driver)
3	Coil resistance	7.0 Ω ± 10%
4	Drive mode	Bipolar constant current drive mode

The ASF rotates the semicircular roller once in reverse before transporting paper into the printer. Along with this motion, the cam in the semicircular roller pushes up the return lever. The return lever then bounces up with tension spring force. As the result, some paper which was fallen off the hopper during the previous feeding motion is all aligned and set back in the hopper. This so called paper return operation is performed for each paper feeding motion. Therefore, paper loading accuracy is improved. See Figure 2-4 which shows how the ASF feeds paper.

After a paper loading motion is completed, the semicircular roller rotates in the normal direction to load the top paper in the stack. This operation is enabled by the correct phase of the gears in the ASF, because the timings for the semicircular roller's contacting the paper surface by the corner (A) and the hopper's being pushed out must be coincided. The ASF sensor is used to determine the condition whether the phase is correct or not. The transmission system of the ASF sensor detects the condition by catching the position of the cam attached onto the same shaft as the semicircular roller is. See Table 2-8 and Table 2-9 for the ASF sensor specifications and its switch mode, respectively.

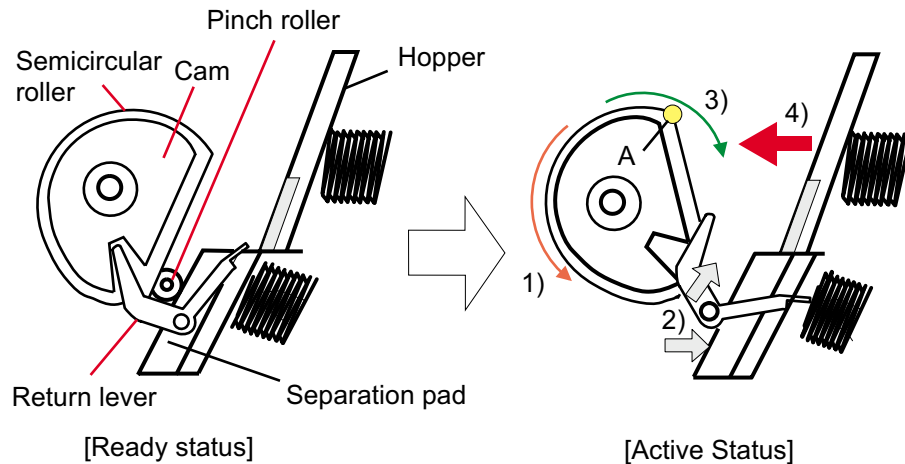

Figure 2-4. ASF Paper Load Mechanism

Table 2-8. ASF Sensor Specifications

No.	Item	Specifications
1	Type	Photoelectric transfer system (transmission type)
2	Collector voltage	30 VDC or less
3	Coil resistance	5 VDC \pm 5%

Table 2-9. ASF Sensor Switch Mode

ASF Position	Sensor Status	Sensor Output
Home position	Open	0.7 VDC or less
Off the home position	Close	2.4 VDC or more

Note that torque from the pump/ASF motor is transmitted to the pump unit depending on the pump/ASF mechanism condition. The rotational directions and corresponding functions are as shown in Table 2-10.

Table 2-10. ASF/Pump Motor Functions

Direction	Functions for ASF	Functions for the ink system
Normal rotation (CW)	<ul style="list-style-type: none"> Reverse rotation of the paper loading roller (paper return control) 	<ul style="list-style-type: none"> Connection to the pump gear train Normal rotation of the pump (absorption) Releases the CR lock. Sets the wiper.
Reverse rotation (CCW)	<ul style="list-style-type: none"> Connection to the ASF gear train Normal rotation of the loading roller (paper separation, paper loading) 	<ul style="list-style-type: none"> Reverse rotation of the pump motor Locks the CR. Resets the wiper.

2.2.4 Paper Feed Mechanism

The paper feed mechanism manages constant paper feeding during printing through to paper ejection. Unlike previous models, the PF motor of this printer only drives the paper feed mechanism, having no connection with the carriage lock mechanism nor the pump mechanism. See Figure 2-5 and Table 2-11 for the cross section of the paper feed mechanism and the PF motor specifications, respectively.

Table 2-11. PF Motor Specifications

No.	Items	Specifications
1	Type	4-phase / 200-pole / HB-type stepping motor
2	Drive voltage	42 VDC \pm 5% (Applied to the driver)
3	Coil resistance	8.1 Ω \pm 10%
4	Drive mode	Bipolar constant current drive mode

For the printer-specific feature, the PF motor pinion transfers torque to the PF drive gear without any transmission gear in between. The gears used for the PF motor pinion and the PF drive gear are very precise. Therefore, note the points below when handling them:

1. Do not touch the gear surface with your bare hands.
2. Keep other parts or tools for servicing such as screw drivers away from the gears.

The PE sensor in the paper feed mechanism is used to check the following:

1. During paper loading, checks if the leading edge of the paper from the ASF is correctly transported.
2. Checks if the paper loaded meets the specifications.
3. Checks if the paper is properly ejected after printing is over.
4. Checks if paper is jamming.

See Table 2-12 and Table 2-13 for the PE sensor specifications and the PE sensor switch mode, respectively.

Table 2-12. PE Sensor Specifications

No.	Item	Specifications
1	Type	Transmission-type photoelectric transfer system
2	Drive voltage	5 VDC \pm 5% (Applied to the driver)
3	Collector resistance	30 VDC or less

Table 2-13. PE Sensor Switch Mode

Paper installation	Switch mode	Output voltage
Not installed	Open	0.7 VDC or less
Installed	Closed	2.4 VDC or more

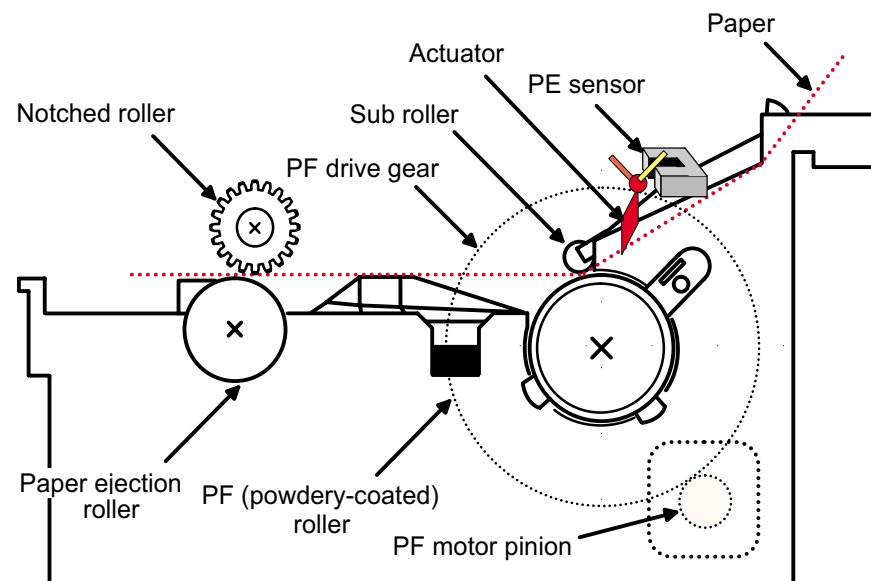

Figure 2-5. Paper Feed Mechanism

2.2.5 Pump/ASF Switch Mechanism

The pump/ASF switch mechanism switches the motor's torque between the paper-loading and the pump-system sides. The pump/ASF motor supplies torque, and a solenoid is used as switching trigger. (Refer to Section 2.2.3 for the pump/ASF motor specifications.) Figure 2-6 shows how the pump/ASF mechanism works when switching to the ASF gear train.

[Switching to the ASF gear train]

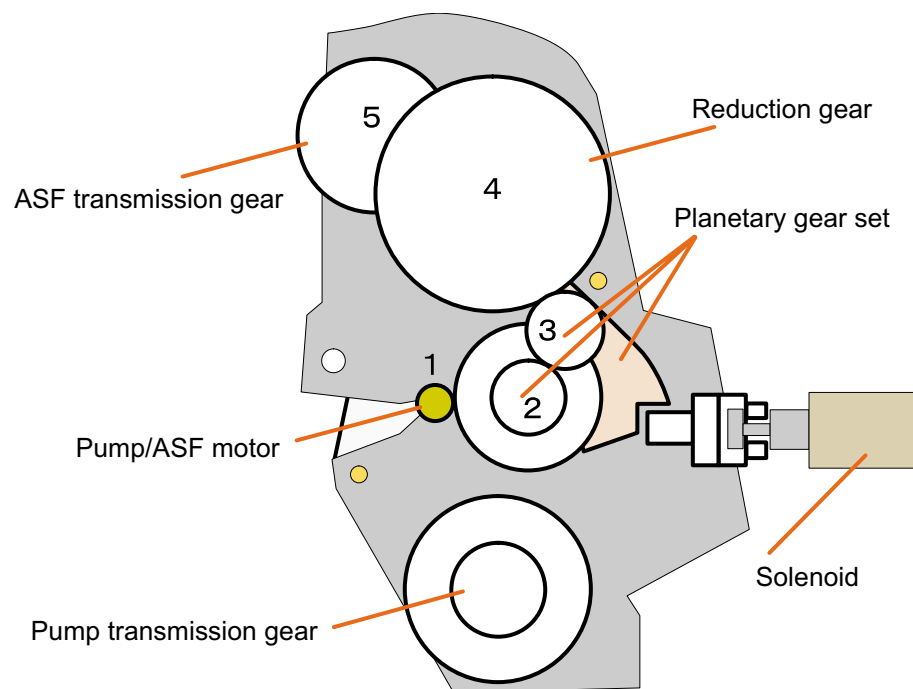

Figure 2-6. Switching Operation to the ASF Gear Train

Figure 2-6 shows the gear condition after switching to the ASF is completed. The steps below describe how the gears move to switch from pump gear train to the ASF gear train.

1. In the pump gear train condition, the gear (3) in the planetary gear set and the pump transmission gear are in mesh.
2. The pump/ASF motor rotates in the normal direction (CW).
3. The whole planetary gear set tries to move up, but the solenoid suppresses it.
4. The solenoid comes on, allowing the whole planetary gear set to move up. At this point, the gear (3) does not rotate, but the motor pinion gear and gear (2) rotate in mesh.
5. The gears (3) and (4) come in mesh and connection to the ASF gear train is fixed when a corner of the solenoid is aligned with the notch in the planetary gear set.
6. Then the gears (4) and (5) are meshed. The gear (5) is connected to the ASF drive gear in the printer mechanism to rotate the roller in the ASF reverse (for paper return mechanism). (Refer to Section 2.2.3 for the paper return mechanism.)

[Switching to the pump gear train]

Figure 2-7 shows the gear condition after switching to the pump gear train is completed.

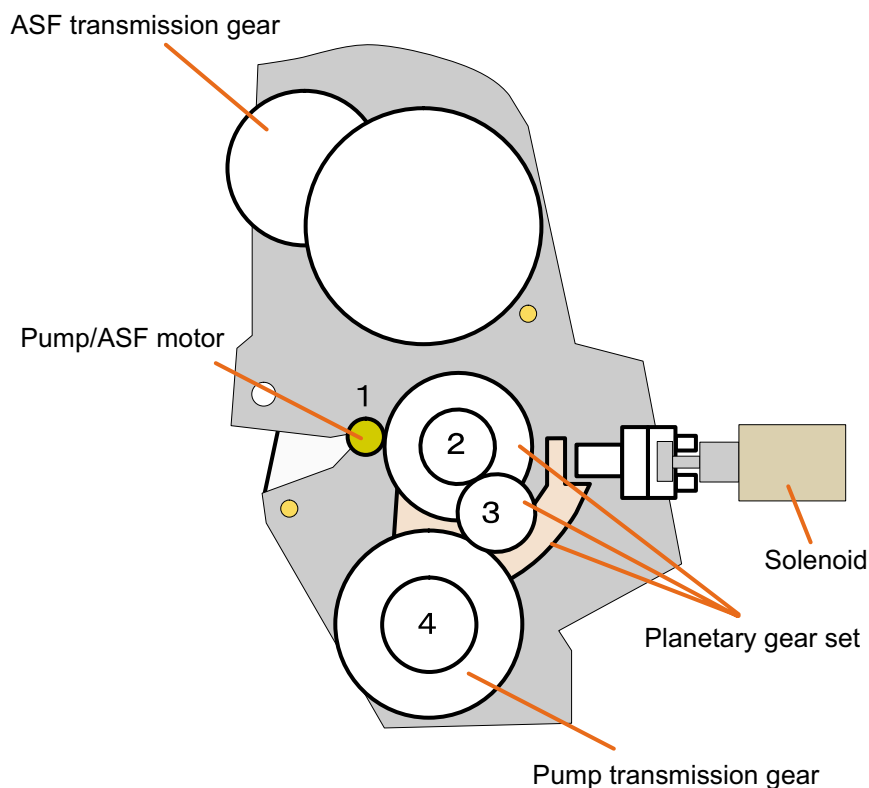

Figure 2-7. Switching to the Pump Gear Train

The steps below show how the gears move to switch from the ASF gear train to the pump gear train.

7. In the ASF gear train condition, the gears (3) and (4) are in mesh.
8. The pump/ASF motor rotates reverse (CCW).
9. The planetary gear set tries to move down, but the solenoid prevents it.
10. The solenoid comes on allowing the whole planetary gear set to move down. At this point, the gear (3) does not rotate, but the motor pinion gear and the gear (2) rotate in mesh.
11. The gears (3) and (4) come in mesh, and the connection to the pump gear train is fixed when a corner of the solenoid is aligned with the notch in the planetary gear set.
12. The gear (4) meshes with the pump transmission gear in the printer mechanism to perform CR lock and pump drive operations.

2.2.6 Pump / Carriage Lock / Head Cleaner Mechanism

The pump mechanism operates in accordance with the carriage lock and head cleaner control mechanisms. Figure 2-8 illustrates the process of torque transmission from the pump/ASF motor to each mechanism.

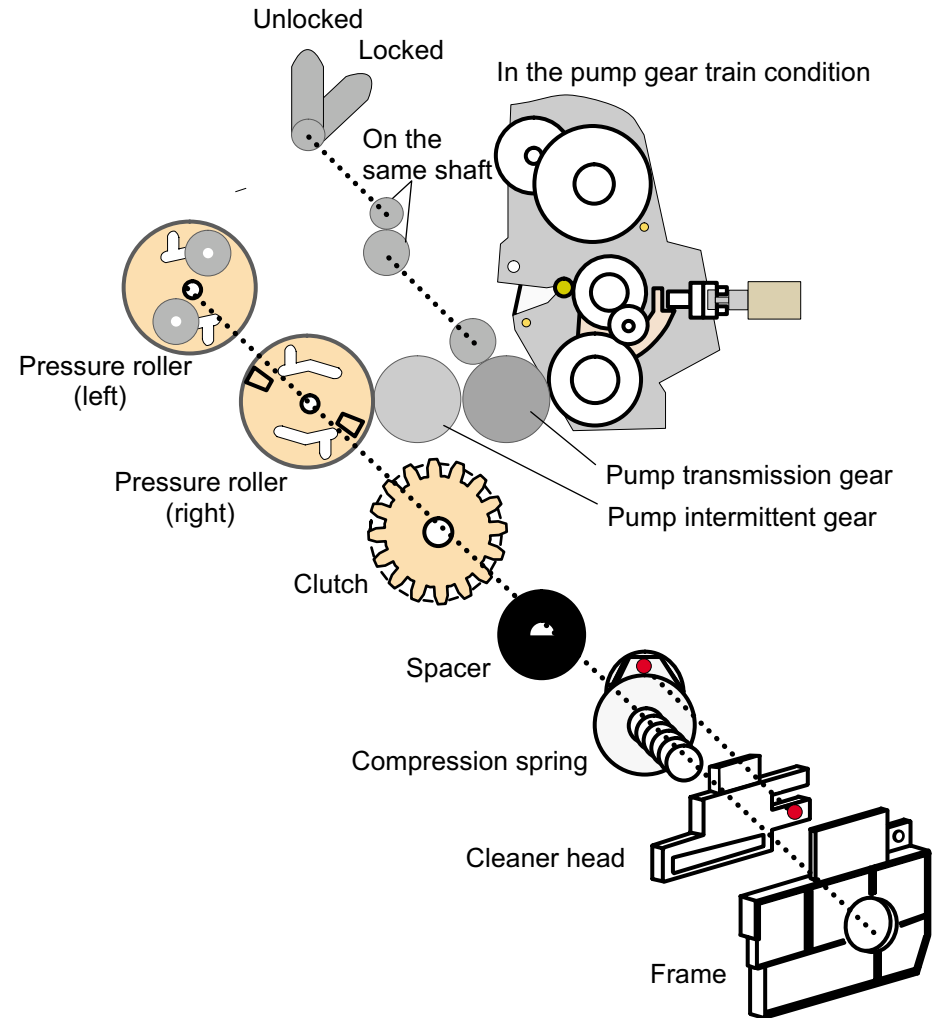

Figure 2-8. Pump / Carriage Lock / Head Cleaner Mechanism

The steps below explain the process of driving each mechanism.

1. The precondition for driving the pump, carriage lock, and head cleaner is that the pump/ASF switch mechanism is switched to the pump gear train. (Refer to Section 2.2.6.)
2. Drive from the pump/ASF motor is transmitted via:
 - 1) pump transmission gear (black) → 2) pump intermittent gear (black) → 3) pressure roller (right) (pump drive roller: flesh color)
3. Along the way, the drive is also transmitted to the carriage lock lever. The carriage lock lever is released with normal rotation of the pump/ASF motor and set with reverse rotation of the motor.
4. Once the drive is transmitted to the pressure roller (right), all parts used to drive the pump begin to act. The Stylus Color 980 has the right and left pressure rollers. However, since the black and color heads are included in one unit, the absorption tube is split in the middle so the 2 pumps can absorb ink in the printhead. See Figure 2-9 which explains the ink absorption process.
5. The cleaner head is located between the pump frame and the cleaner head drive roller, and a compression spring is set between the cleaner head and the cleaner drive roller. Since the cleaner head has a protrusion (marked with a red circle in Figure 2-8) on it on the roller side, it moves back and forth along with the roller rotation. However, if the roller rotates faster than the specific level, it rotates alone because tension of the compression spring does not work any more.

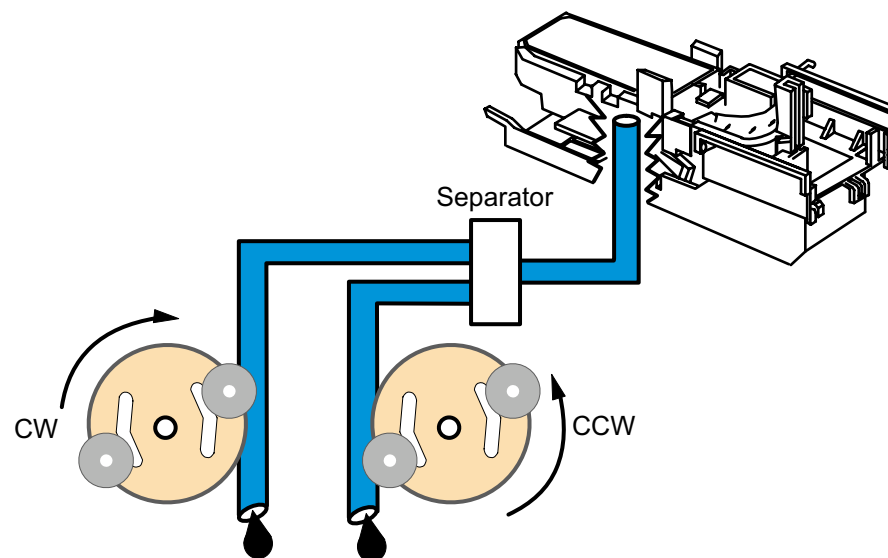

Figure 2-9. Ink Absorption Process

2.3 Electrical Circuit Operation Principles

The Stylus Color 980 consists of the following circuit boards:

- C380 main board
- C265 PSB/PSE board
- C265 Panel Board

2.3.1 C265 PSB/PSE Power Supply Board

This section explains the operating principles of the C265 PSB/PSE board, in order.

AC power supply voltage is supplied from the AC power socket. Then the fuse (F1) limits the incoming current of the AC voltage to avoid damaging the C380 main board and C265 PSB/PSE board. On the other hand, TH1 and TH2 serve to convert surplus input voltage into heat energy.

The input voltage is next input to the RLC parallel circuit (a filter circuit), for higher harmonics absorption. This operation keeps the higher harmonics in the AC power out of the printer, and also prevents leakage of higher harmonics generated in the printer.

After noise is removed, the AC voltage goes through the full-wave rectification circuit. The minus component of the alternate wave is eliminated as the result.

Then the voltage is smoothed by the electrolysis condenser (C11) for stabilized DC voltage, and the current is applied to the primary side of the transformer (T1).

The current, however, does not flow into the primary side of the transformer (T1) if the main switching FET (Q1) located in the primary side is off. The Q1 comes on when the voltage is applied to the gate through the R28, a starting resistor, when the printer is turned on. While the Q1 is on, current does not flow into the secondary side; because a reverse-characteristics diode is used to connect to the secondary side.

The transformer (T1) is gradually charged with the current. When it is full and not charged any more, the gate voltage of the Q1 starts going down gradually. At this point, C13 abruptly pulls in the gate voltage of the Q1 to turn the Q1 off.

Once the Q1 is off, the energy charged in the primary side flows into the secondary side all at once. This occurs because the energy transfers in the same direction as the reverse diode characteristics with the Q1 off.

The secondary side of the transformer (T1), which has the specified numbers of coiling lines for 42 VDC production, creates the 42 VDC out of the energy led to the secondary side by the electromagnetic induction.

The secondary side has numbers of stabilizing circuits to output stabilized voltages, as listed below:

- Smoothing circuit:
Since the energy led from the transformer (T1) to the secondary side by the electromagnetic induction is alternating current, it must be smoothed by the electrolysis condensers C51 and C52 to be direct current.
- +42 V line constant voltage control circuit:
7 zener diodes (ZD51, ZD81 - ZD86) connected in series monitors +42 V status used to drive various mechanisms. To keep the output voltage at a constant level, the circuit controls the on/off timing of the Q1 slightly according to the signals fed back from the photocoupler (PC1).
- +42 V line overvoltage protection circuit:
This circuit includes 2 zener diodes (ZD52, ZD87) connected in series. It monitors the +42 V line used to drive various mechanisms to detect abnormal rise in the voltage level caused by a defect in the circuit. If the output voltage rises to +48 V, the signal is input to a port of one of the 2 channels in the photocoupler (PC1) to completely cut off the Q1 operation. Once this circuit is active, a normal flow does not recover unless the printer is turned off and back on.
- +5 VDC production circuit:
L4960 (IC51) produces +5 VDC out of +42 VDC. Since the IC internally operates PWM control, it can always produce constant

+5 VDC by changing output pulses in spite of diverse input voltage levels. This operation serves as a constant voltage control circuit.

- +5 V line overvoltage protection circuit:
ZD53 in the circuit monitors the +5 V line for overcurrent. In case the voltage rises to 7 V for reasons such as a defective board, the circuit shuts the Q1 gate in the same process as the +42 V line overvoltage protection circuit follows.
- Voltage drop delay circuit at power off
The C265 PSB/PSE board uses the secondary switch that includes the delay circuit. The delay circuit allows the printer to complete the power off operation properly even though the printer is turned off while it is printing.
A normal power off operation by the user is monitored by the C380 main board. When it detects a power off, the program immediately starts the power-off sequence, capping the printheads, and drops the power.
The electrolysis condenser (C84) continues to operate to allow the printer to execute this proper power off sequence.

See the following page for the electrical circuit diagram.

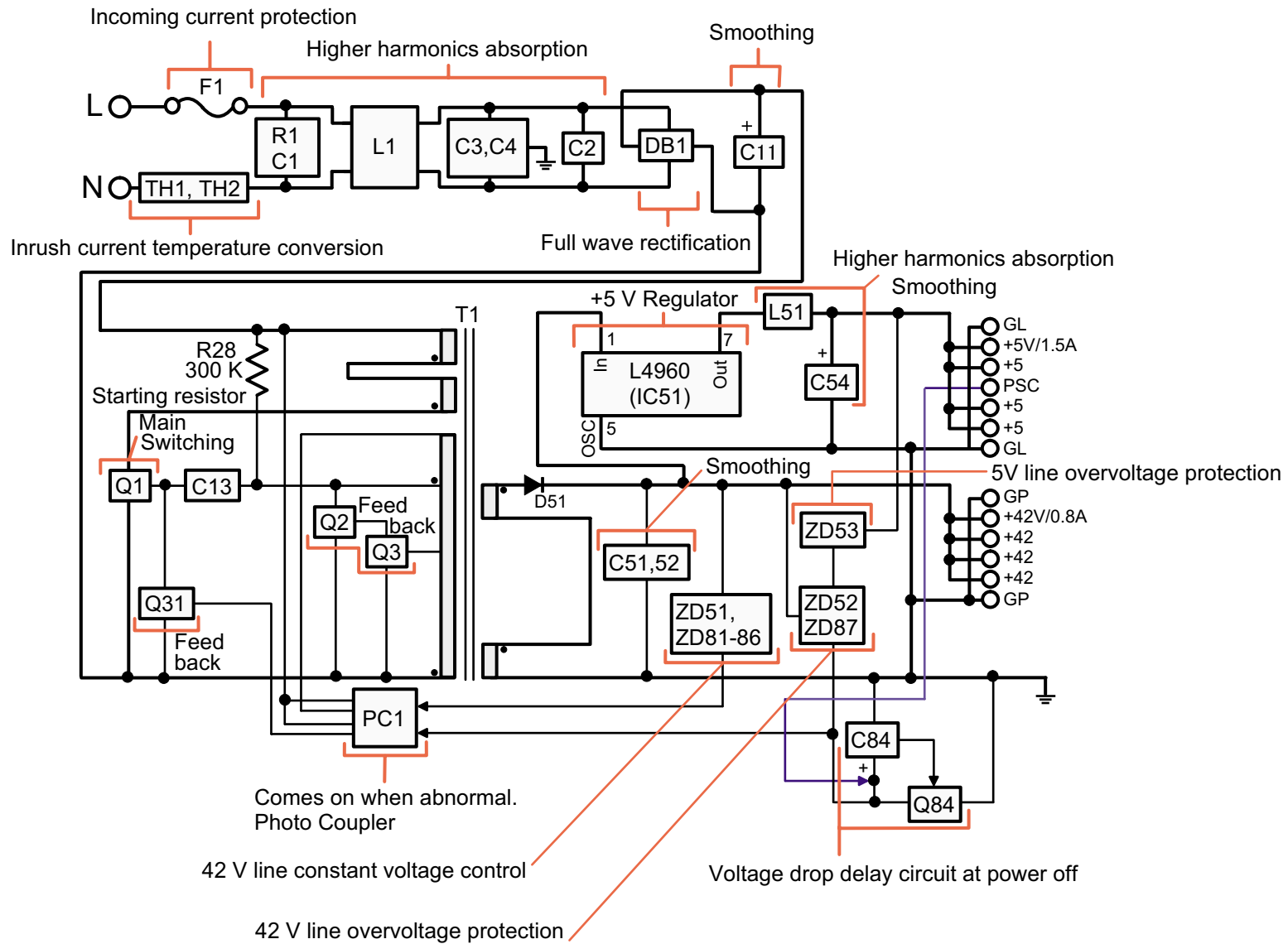

Figure 2-10. C265 PSB/PSE Board Circuit Block Diagram

2.3.2 C380Main Board

See Figure 2-11 for the C380 main board block diagram.

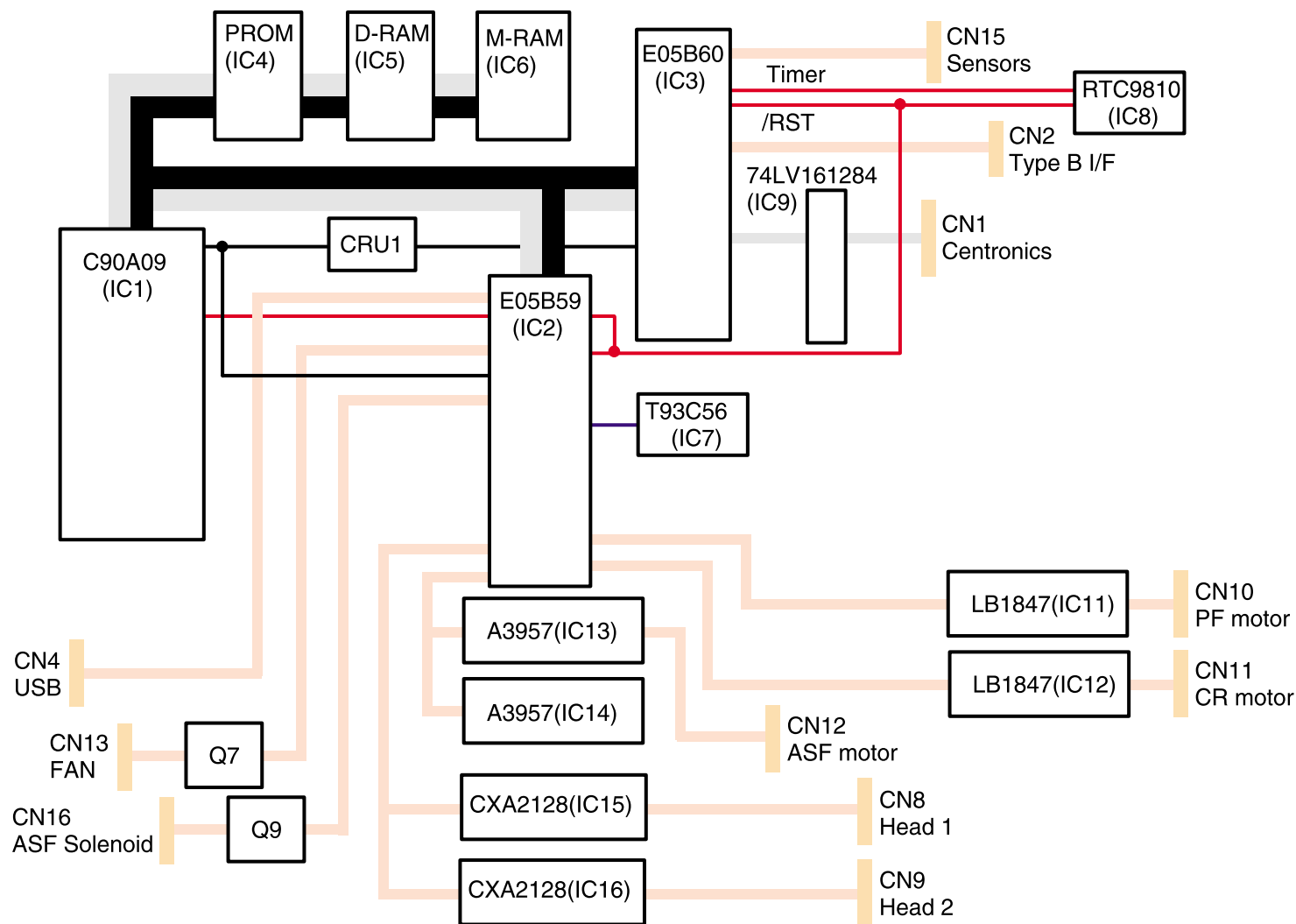

Figure 2-11. C380 Main Board Block Diagram

The following tables list the major components on the C380 main board and their functions.

Table 2-14. Major Components on the C380 Main Board (1/2)

Component	Functions
CPU:	<ul style="list-style-type: none"> • A EPSON'S CPU. • Performs high-speed data processing running at 24.0 Mhz with an external transmitter. • Bus width is 16-bit.
ASIC 1: (E05B60: IC3)	<ul style="list-style-type: none"> • Controls all interfaces but USB. • Monitors the signal from each sensor.
ASIC 2: (E05B59: IC2)	<ul style="list-style-type: none"> • Controls printheads, motors, ASF solenoid, cooling fan, USB I/F, and EEPROM.
PROM/MROM:	<ul style="list-style-type: none"> • For PROM, either one-time PROM or Mask ROM is used. Specifications vary depending on the destinations, as shown below: <Standard version> <ul style="list-style-type: none"> • PROM size: 16 M bit • Contents: Unattached • Bus width: 16 bit <NLSP version> <ul style="list-style-type: none"> • PROM size: 16 M bit • Contents: 16 M bit • Bus width: 16 bit
D-RAM:	<ul style="list-style-type: none"> • Manages the various buffers and work area. • Bus width is 16 M bit.
Timer IC: (RTC9810: IC8)	<ul style="list-style-type: none"> • Counts total power off time of the printer, which offers the basis for determining the cleaning type to be performed at the next power on. Power is supplied by an external button-cell battery (a lithium battery). This IC also serves to produce reset signals connecting to each major IC, such as CPU, ASIC1, ASIC 2, and motor drive ICs. The head driver ICs (CXA2128 x 2: IC15 and IC16) individually produce a reset signal when detecting abnormal voltage so the printhead can stop in the proper sequence.

Table 2-15. Major Components on the C265 Main Board (2/2)

Component	Functions
Motor driver IC (LB1847: IC11, 12) (A3957: IC13, 14)	<ul style="list-style-type: none"> • The LB1847 (IC11 and IC12) is used to drive PF motor and CR motor and enables 4W1-2 phase excitation mode for the first in EPSON line. This control system, called micro stepping, materializes the control of the carriage vibration during printing and improvement of accuracy in paper feeding on the hardware basis. • The A3957 (IC13 and IC14) used to drive Pump, ASF motor also supports the 4W1-2 phase excitation mode on the hardware basis, but differs from the former IC in the point that the IC13 and IC14 individually excite the phase A and B.
Head driver IC (CXA2128 x 2: IC15, 16)	<ul style="list-style-type: none"> • The head driver ICs, directory attached to the board, consist of two separate circuits; charging circuit and discharging circuit, to produce trapezoidal waveform. This IC creates the trapezoidal waveform by combining the signals input from the input port E05B59 (IC2) of the IC. This is performed to change the characteristics and voltage levels of charging and discharging, and the trapezoidal waveforms specific to normal dot print and micro dot print are produced as the result.

The control circuits are explained in detail below.

[Combined (reset circuit + timer) circuit]

A combined circuit RTC9810 manages both reset signal production and RTC (Rear Time Controller). It produces reset signals by monitoring the both 5 VDC line (input to Pin 7) and 42 VDC line (input to Pin 9). When the voltage level for the 5 VDC line drops to 4.3 V, or the voltage level for the 42 VDC line drops to 35.5 V, the combined circuit outputs a reset signal from Pin 2. When the printer is turned on / off or detects abnormal voltage level, the IC sends the reset signal to the following ICs to avoid printer damage caused by run-away of the logic line and abnormal operation of driver systems. Also, to let the motor driver IC execute its

job properly, the reset signal is once input to the convertor (setting current production IC) on the main board to stop motors in the correct sequence.

On the other hand, the timer control is done by counting the operation of the oscillator circuit, and the printer's power off time can be confirmed based on the timer at the next power on operation. Also, this count data is used to manage the timer for the operation such as periodical flashing during power on time as well as power off time.

While the printer is on, the printer supplies 5 V (input to Pin 7) to operate the internal oscillation circuit, however, when the printer is turned off, the external button-cell battery (a lithium battery) immediately starts supplying voltage (3 V) to the Pin 8.

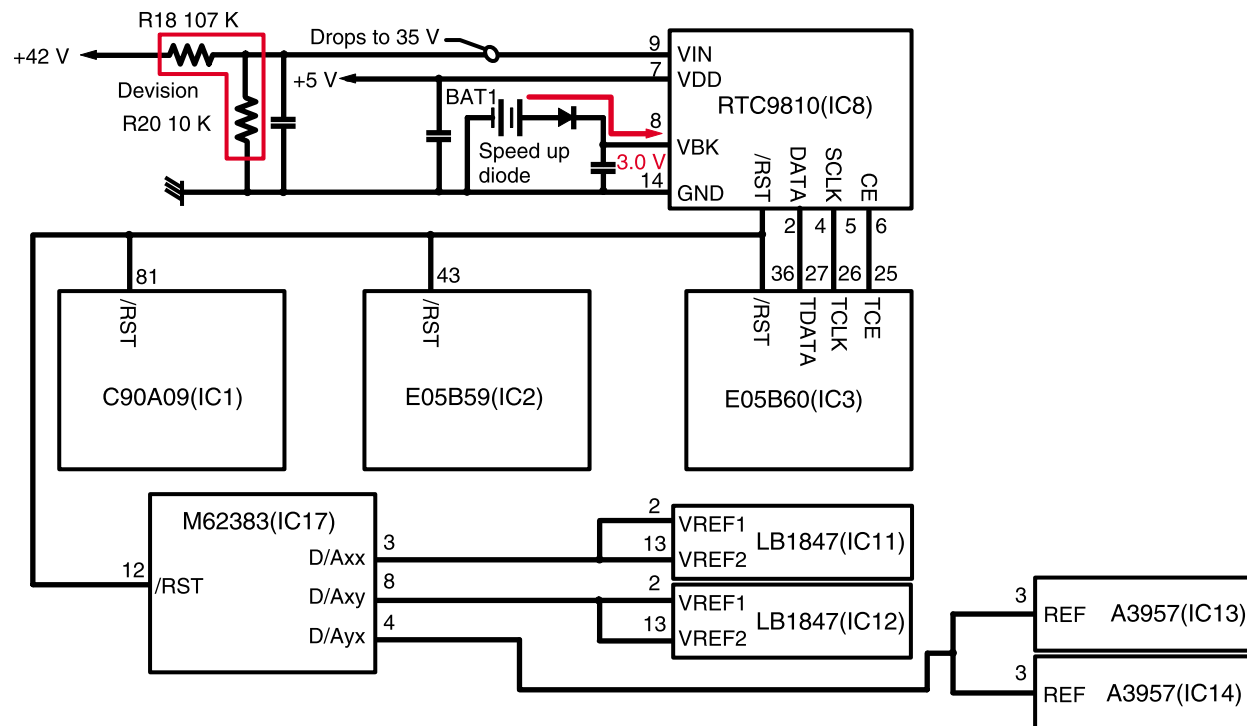

Figure 2-12. Reset/timer combined circuit

[Sensor circuit]

The sensors attached to the printer are as described in the following pages. They are basically divided into 2 major parts: 1) abnormal temperature detection part and 2) mechanism status detection part. The former is controlled by the CPU and the latter is controlled by 2 ASICs; E05B59 (IC2) and E05B60 (IC3).

1) Abnormal temperature detection part

This abnormal temperature detection part is composed of 3 thermistors and the temperature detection circuit which is included in the nozzle selector inside the printhead. The CPU's analog ports used for temperature detection and their functions are as follows:

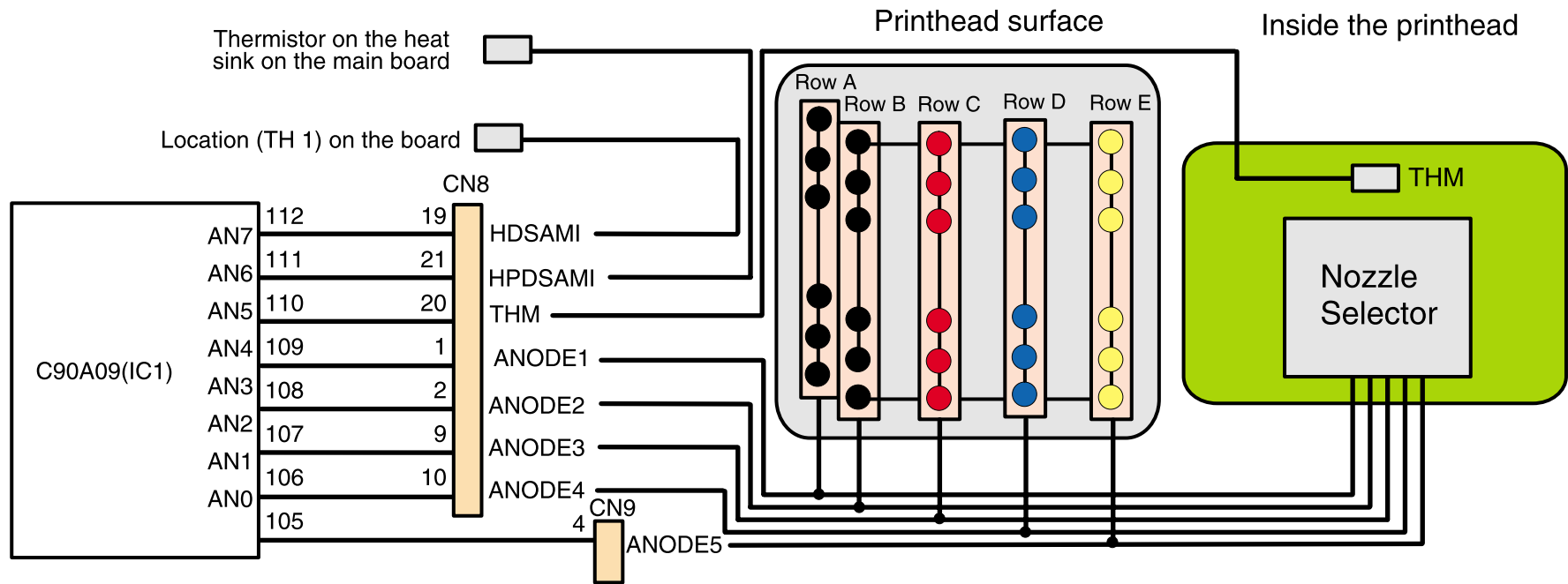

Figure 2-13. Sensor Circuit Block Diagram (Abnormal Temperature Detection Circuit)

□ AN7 (Pin 112)

The TH1, located between 2 pre-driver ICs (the head driver ICs; IC15 and IC16) on the main board, monitors temperatures around the board. A Pre-Driver IC is exclusively developed to create intricate trapezoidal waveforms which vary depending on the model. It uses +42 VDC and high frequency to produce trapezoidal waveforms. Therefore, if any relevant trouble has occurred, it is assumed that the driver is overheated. The TH1 works to detect this kind of unexpected rise in temperature at an early stage and stop printing.

□ AN6 (Pin 111)

Four power transistors (Q3 - Q6) used for trapezoidal waveform production are directly attached with screws to the large heat sink (a radiation plate) on the main board. Since the printhead supported by the Stylus Color 980 supports very high driving frequency (28.8 KHz), higher than ever, and a large amount of PZT, radiation from the discharging transistor used for trapezoidal waveform production is huge. Therefore, the cooling fan on the board forces out heat around the radiation plate. A thermistor fixed on the radiation plate sends signals to the AN6 port of the CPU to allow the CPU to manage the cooling fan's on/off operation.

□ AN5 (Pin 110)

The electrical signal input to this port is a temperature signal sent from the thermistor included in the printhead unit. The function of this thermistor is, same as before, to precisely detect temperatures around the printhead and feed back information to the C380 main board. Based on the fed back information, the printer manages subtle change in the voltage level of the head drive trapezoidal waveform, and also can eject the correct amount of ink as it is aimed at any temperature.

□ AN4-ANO (Pins 1, 2, 9, 10, 4)

The nozzle selector IC is attached inside the printhead. It determines which nozzle is used to fire ink according to serial data sent from the ASIC (IC2). A temperature detection circuit included in the nozzle selector detects the temperature of each actuator in the 5-row PZT array. This must be performed to avoid false firing. If the printhead continues the firing motion, but no ink is ejected, the temperature inside the printhead rises to 100 °C and the printhead might be damaged as a result. To prevent this from happening, the abnormal temperature detection circuit is included in the nozzle selector circuit.

The followings are possible reasons for false firing:

1. If an ink cartridge has been removed before its life end and is installed again, the ink consumption counter value is upset, and the counter fails to detect the actual remaining ink level. This wrong operation dangerously causes the printhead to keep firing without any ink remaining in the cartridge.
2. Serious dot missing can also cause false firing. In this case, there is enough ink in the cartridge, but it does not properly flow into the head because of a clogged nozzle(s). If the PZT is driven without any ink flow, heat generated by the nozzle movement can not be released, and this makes the temperature around the head abnormally high.
3. Strong vertical impact applied to the head causes a considerable amount of ink around the nozzle to leak all at once as well as damages meniscus on the head surface. As a result, ink does not properly eject at the next printing and ends up in a false firing status.

False firing is detected in the following conditions, and the printer handles it as described below.

■ False firing detection timing:

If any of the 5 channels, which are monitored by the abnormal temperature detection circuit in the nozzle selector, reaches 100 °C, the printer stops printing and automatically begins the cleaning cycle. In this case, the printer runs the most powerful cleaning cycle. The particular address bit called abnormal temperature detection flag is reset at this point.

■ Process after detection:

The printer does not resume printing until the temperature around the PZT recovers to the tolerable range. In case the printer detects the same abnormal condition again, it indicates an ink-end error to urge the user to replace the cartridge considering the following possible reasons:

1. The currently installed ink cartridge is far beyond its useful life (6 months). Ink, in this condition, does not eject properly and results in a false firing. When a new cartridge is installed, the problem is solved.
2. The cartridge installed has been repeatedly removed and then installed again several times. With this mis-handling of the cartridge, the ink consumption counter can not properly describe the actual remaining ink level, and a false firing occurs as a result. The solution in this case is also replacing the ink cartridge with a new one.

Furthermore, If an ink cartridge is removed from the printer, air comes in and bubbles inside the cartridge. Unlike a new cartridge, the ink inside the removed cartridges is not deaerated, so the bubbles inside can not be absorbed into the ink due to the ink's saturated condition. For this reason,

the more the cartridge is removed/installed, the more bubbles are formed, and the printhead can not eject ink properly and false firing occurs.

[Mechanism status detection part]

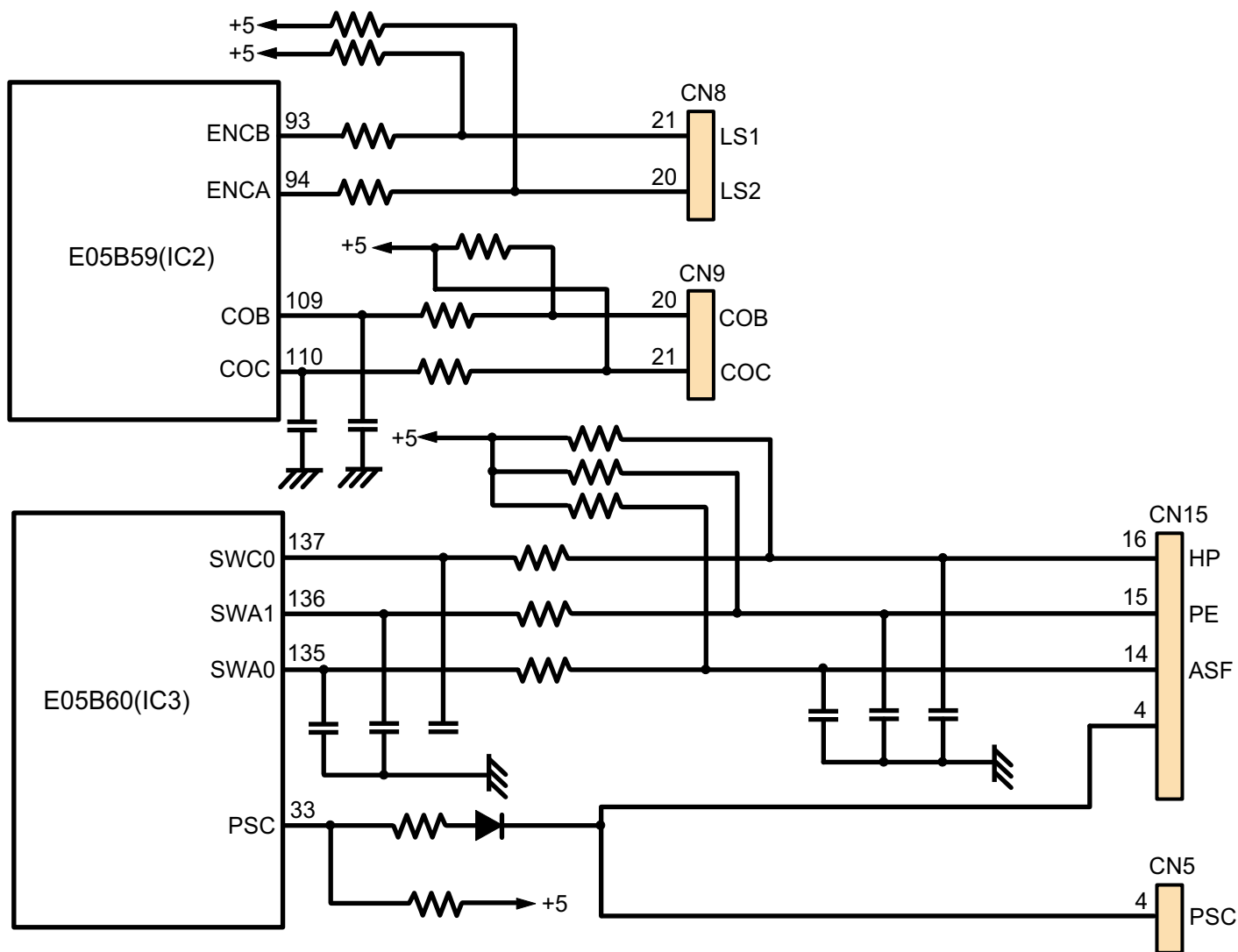

Figure 2-14. Sensor Circuit Block Diagram (Mechanism Status Detection Part)

- Encoder:

This sensor increases accuracy of ink ejection timing. Irregular movement of the carriage, usually caused by a paper jam, can be also detected based on the change in input signals of this sensor. Carriage movement is monitored by running the encoder belt (with lines printed on it with increments of 180 dpi) between the photo sensor attached to the carriage. Also, if the printer receives a large impact during printing, the input signal can not be properly read, and in some cases print quality decreases with a dot missing problem. This is because this printer forms one dot by producing trapezoidal head driving waveform based on the cycle determined by the signals sent from the encoder.
- Ink cartridge sensor:

If the printhead drives without any ink cartridge installed (= false firing), it damages the printhead unit. Also, compared with other printers, this printer uses the largest number of PZT and accordingly releases more heat. For this reason, the ink itself inside the cartridge serves to lower the temperature inside the cartridge, and black and color ink cartridges can be separately detected to avoid false firing.

Detection process: An ink cartridge is detected when the ink cartridge being installed activates the actuators, which then pushes the micro switch.
- CR home position sensor:

When the printer is turned on, the CRHP sensor confirms the CR is in the home position during the home position seeking sequence. Then the printer can determine the CR control afterwards. The printing column position is also confirmed based on the signals from the sensor.

Detection process: The carriage is detected when the flag interrupts the light beam in the photo sensor which is located on the right end of the printer mechanism.
- PE (Paper End) sensor:

The PE sensor detects the following conditions:

 - Whether or not paper is set at power on.
 - Whether or not paper is properly fed from the ASF with the paper feed command.
 - Whether or not the printer properly ejects a page of printed paper after rotating the PF (Paper Feed) motor with the predefined distance.

Detection method: A photo sensor is used to detect the actuator's motion; the actuator is pushed/released by the leading/rear edge of the paper.
- ASF sensor:

Various parts in the ASF are engaged in the phase that is designed to feed paper at the appropriate timing. If the timing is wrong, mismatch occurs between paper feeding by the ASF and paper transportation for printing, and non-feeding or paper jam will occur. Therefore, this printer monitors the sensor condition at power on and before and after paper is fed/ejected according to the pump/ASF motor's rotational distance.
- Power on/off detection:

Unlike primary-side switch type products, ASIC E05B60 (IC3) on the C380 main board is used to monitor the power on/off operation instead of any sensor. When the power switch on the control panel is turned off, the change from 5 V to ground level is detected at the Pin 33 of the IC3, and the program starts the power off sequence with this change. Power used during the sequence is supplied by the electrolysis condenser C84 in the voltage drop delay circuit in the secondary side of the C265 PSB/PSE board. The electrolysis condenser continues to supply power until all electric charge inside is completely discharged.

2.3.3 CR Motor Driver Circuit

An exclusive motor drive IC (LB1847: IC12) enables 4W1-2 phase excitation on the hardware basis. A micro stepping motor is used for the CR motor to move the carriage accurately and also to improve printing accuracy by minimizing the motor's vibration during printing. Figure 2-15 shows the CR motor driver circuit block diagram.

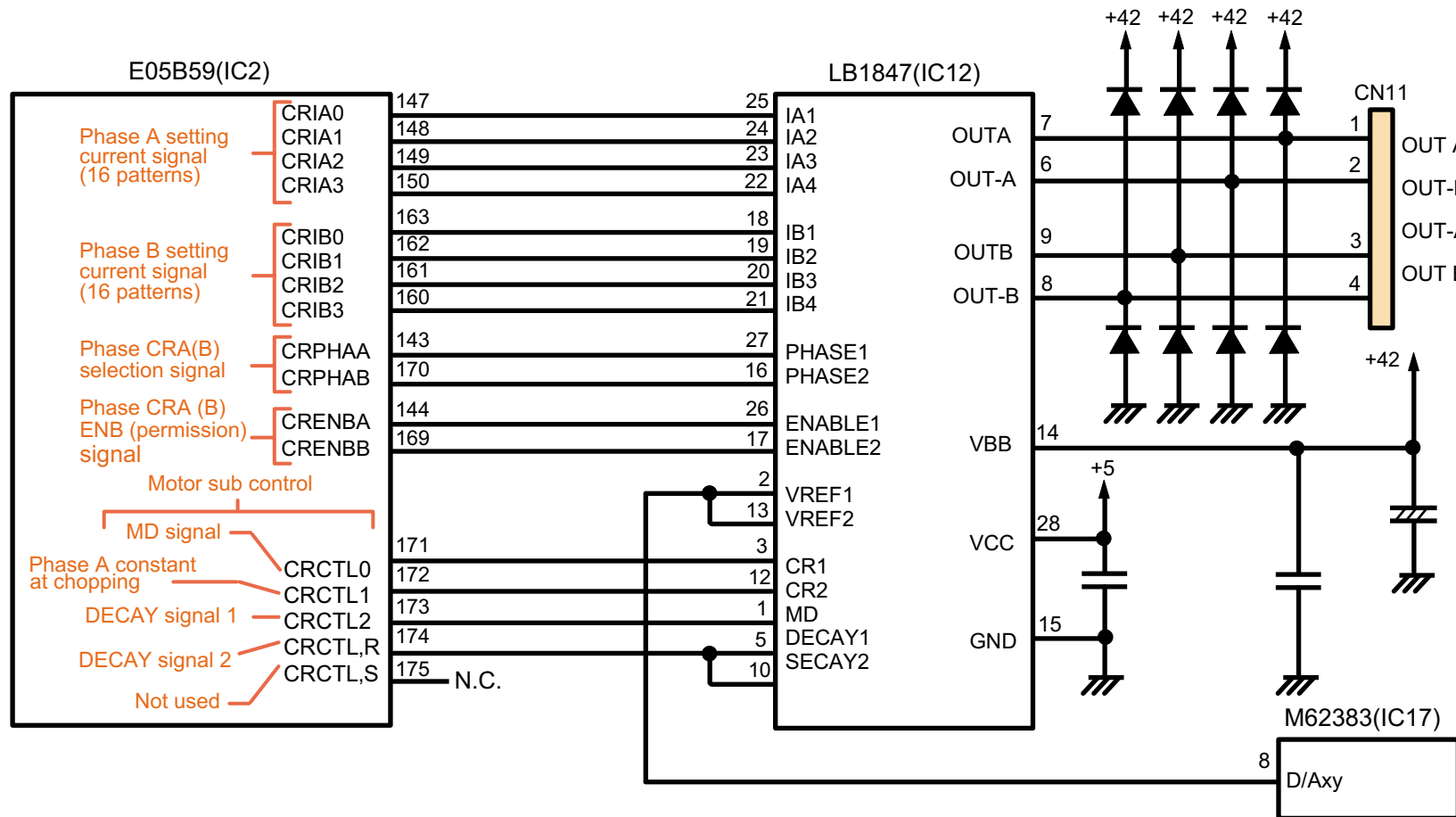

Figure 2-15. CR Motor Driver Circuit Block Diagram

Unlike previous EPSON ink jet printers, the number of the phase excitation input ports in the motor drive IC of this printer has increased to 8. The previous micro step system used total of 4 phase excitation input signals for both phases A and B. (Stylus COLOR, Stylus PRO series, and Stylus PRO XL series are exceptional, since they transfer 4-bit serial data from ASIC to the motor driver.) This is because the micro stepping was controlled by the software only. On the other hand, LB1847 enables the 4W1-2 phase excitation using the hardware and is equipped with the necessary number of input ports (8 ports) for current setting signals. Among these input ports, 4 ports are allocated to each phase, A and B. Therefore, 16 types of current setting data can be constantly sent to the driver IC. The LB1847 controls the micro stepping system by exciting the corresponding phase based on the combinations of the setting signals sent from the ASIC.

Table 2-16 shows the excitation modes used for the CR motor and their usage.

Table 2-16. CR Motor Excitation Mode and Usage

Excitation mode	Usage	Minimum step
2-2 phase drive	LQ print mode	1/120" (0.212 mm)
1-2 phase drive	Not used	1/240" (0.106 mm)
W1-2 phase drive	Sort skipping SLQ print mode	1/480" (0.053 mm)
2W1-2 phase drive	Wiping Capping	1/960" (0.026 mm)
4W1-2 phase drive	Moving from the capping position Uncapping	1/1920" (0.013 mm)

2.3.4 PF Motor Driver Circuit

Motor drive exclusive IC (LB1847: IC11) enables 4W1-2 phase excitation on the hardware basis. A stepping motor is used for the PF motor to move the carriage accurately and also to improve printing accuracy by minimizing the motor's vibration during printing. Figure 2-16 shows the PF motor driver circuit block diagram.

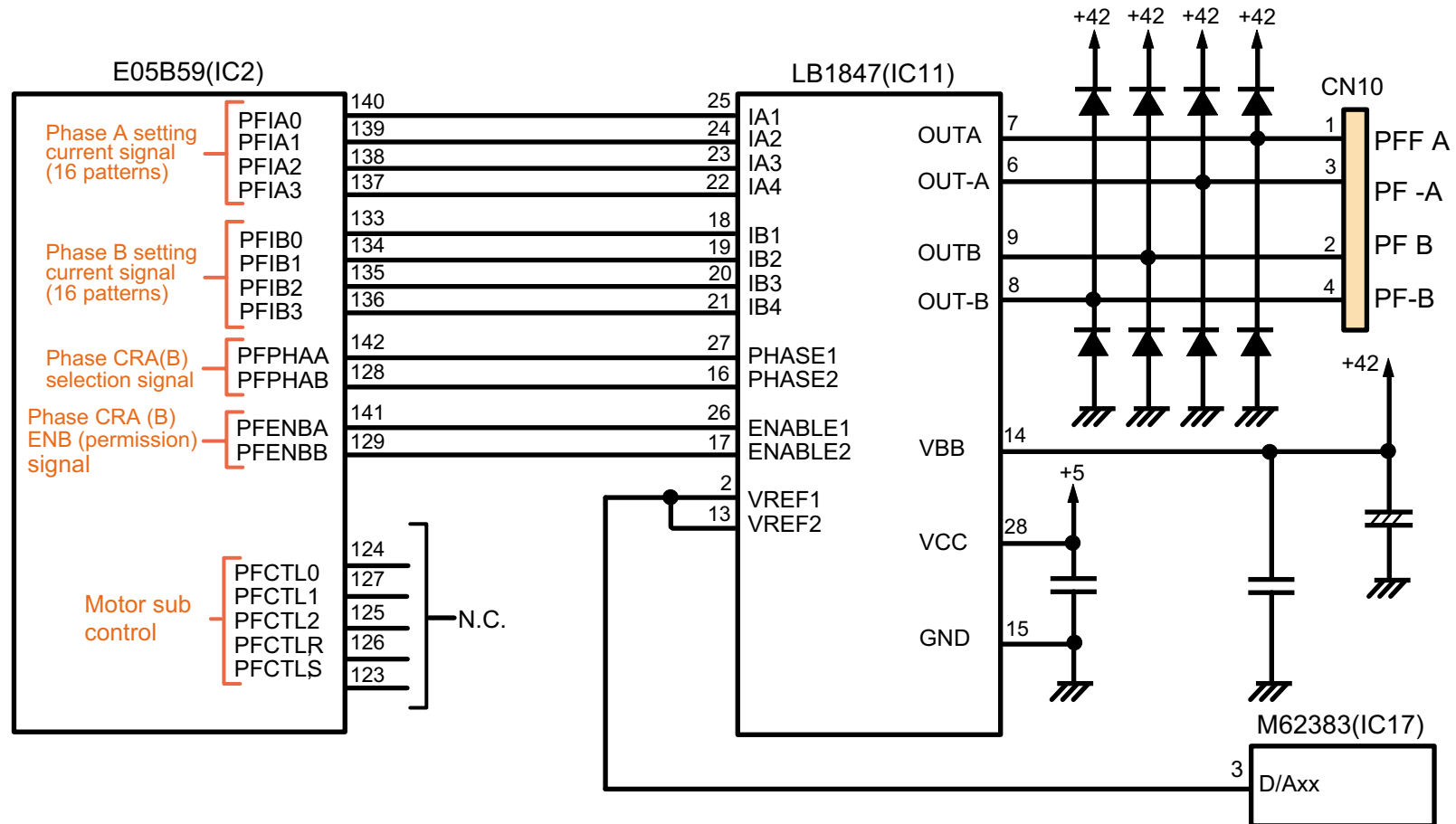

Figure 2-16. PF Motor Driver Circuit Block Diagram

Unlike the previous EPSON ink jet printers, the number of the phase excitation input ports in the motor drive IC of this printer has increased to 8. The previous micro step system used total of 4 phase excitation input signals for both Phase A and Phase B. (Stylus COLOR, Stylus PRO series, and Stylus PRO XL series are exceptional, since they transfer 4-bit serial data from ASIC to the motor driver.) This is because the micro stepping was controlled by the software only. On the other hand, LB1847 enables 4W1-2 phase excitation using the hardware and is equipped with the necessary number of input ports (8 ports) for current setting signals. Among 8 input ports, 4 are allocated to each phase, A and B. Therefore, 16 types of current setting data can be constantly sent to the driver IC. The LB1847 controls the micro stepping system by exciting the corresponding phase based on the combinations of the setting signals sent from the ASIC.

Table 2-17 shows the excitation modes used for the PF motor and their usage.

Table 2-17. PF Motor Excitation Mode and Usage

Excitation phase	Usage	Minimum step
2-2 phase drive	Not used	1/720"(0.035 mm)
1-2 phase drive	Fast feed 1 Fast feed 2 Special fast feed	1/1440"(0.018 mm)
W1-2 phase drive	Not used	1/2880"(0.009 mm)
2W1-2 phase drive	Middle-speed feed	1/5760"(0.004 mm)
4W1-2 phase drive	Normal feed Micro adjust feed Slow feed	1/11520"(0.004 mm)

2.3.5 Pump/ASF Motor Driver Circuit

Like for the CR motor and the PF motor, A3957 (IC13, IC14) enables the pump/ASF motor to perform 4W1-2 phase excitation on the hardware basis. Figure 2-17 shows the pump/ASF motor driver circuit block diagram. Among 2 drivers, IC13 and IC14 drives the Phase A and Phase B, respectively.

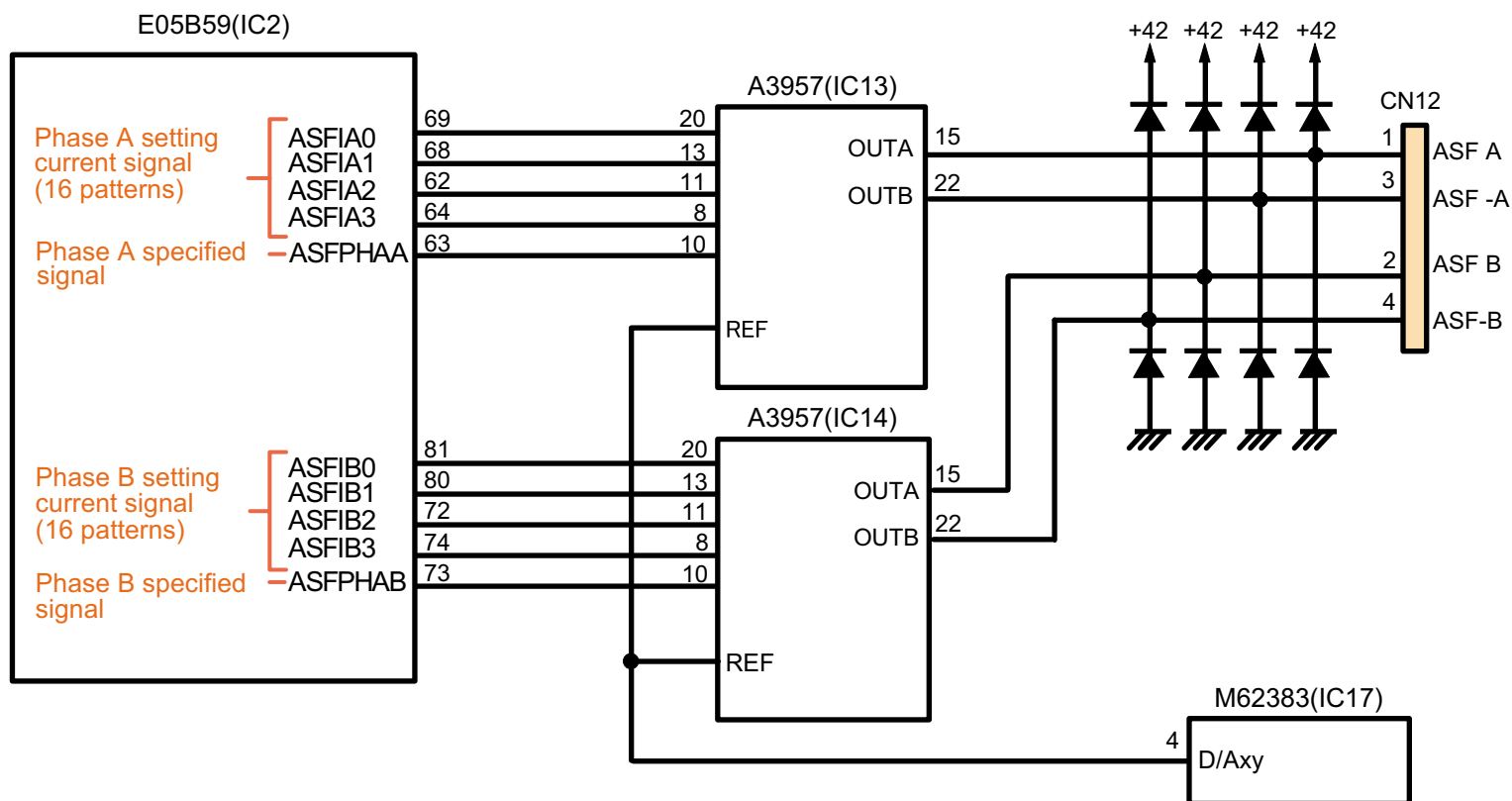

Figure 2-17. Pump/ASF Motor Driver Circuit Block Diagram

Table 2-18 shows the excitation modes used for the pump/ASF motor and their usage.

Table 2-18. Pump/ASF Motor Excitation Mode and Usage

Excitation phase	Usage	Minimum step
2-2 phase drive	Fast absorption Semi-fast absorption Fast feed	1/720" (0.035 mm)
1-2 phase drive	Micro absorption	1/1440" (0.018 mm)
W1-2 phase drive	Not used	1/2880" (0.009 mm)
2W1-2 phase drive	Normal absorption Normal feed	1/5760" (0.004 mm)
4W1-2 phase drive	Constant drive Slow feed Slow absorption	1/11520" (0.004 mm)

2.3.6 Printhead Driver Circuit

The printhead driver circuit consists of 2 circuits: the common voltage production circuit (a trapezoid waveform production circuit) on the C380 main board and nozzle selector on the printhead. The pre-driver CXA2128 (IC15, 16) produces trapezoid waveform and the transistors (Q3 - Q6) output it. Unlike previous products, data (serial data) is independently transferred to each nozzle row to enable reduction in data latch time required to form one dot, while nozzle selection is performed by ASIC, which sends serial data directly to the nozzle selector on the printhead synchronizing with the clock signal. (A block diagram and the circuit diagram for the nozzle selector are not included in this manual.) The printhead driver circuit block diagram is shown in Figure 2-18.

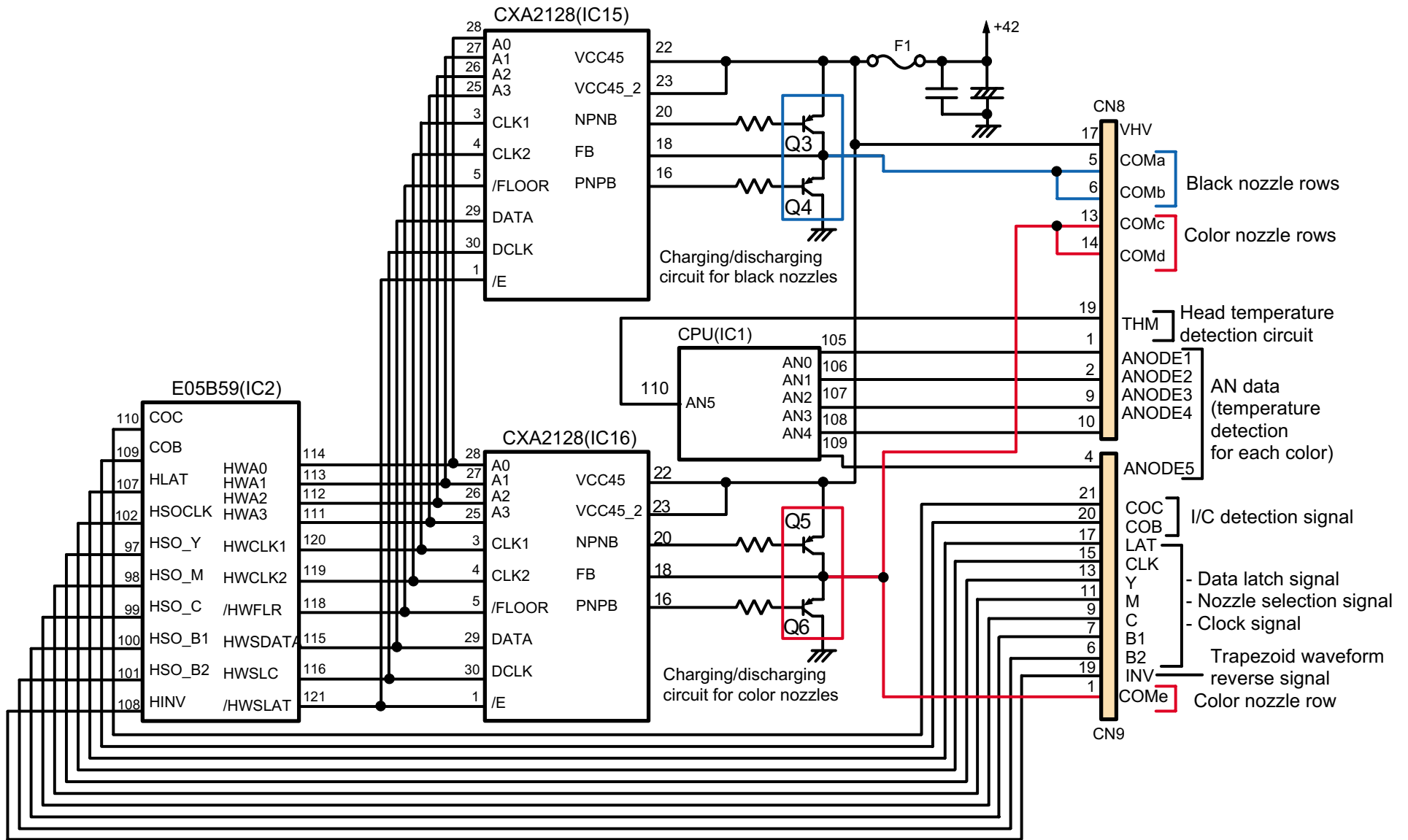

Figure 2-18. Printhead Driver Circuit Block Diagram

2.3.7 Cooling Fan Driver Circuit

Since this printer drives a large number of PZT elements (total of 480 nozzles) with a high drive frequency (maximum 32.4 K Hz), heat radiated around the printheads and the trapezoid waveform production circuit on the C380 main board is considerably large compared to other printers. Therefore a thermistor is attached to the heat sink fixed to the trapezoid waveform production transistors to prevent the trapezoid waveform production transistors (Q3 - Q6) and adjacent HIC from operating abnormally due to high temperature. When the thermistor detects abnormally high temperature, the printer turns the cooling fan on to forcibly blow out heat from the lower case. Figure 2-19 shows the cooling fan driver circuit block diagram. Table 2-19 shows how the signals output from the ASIC and corresponding fan conditions.

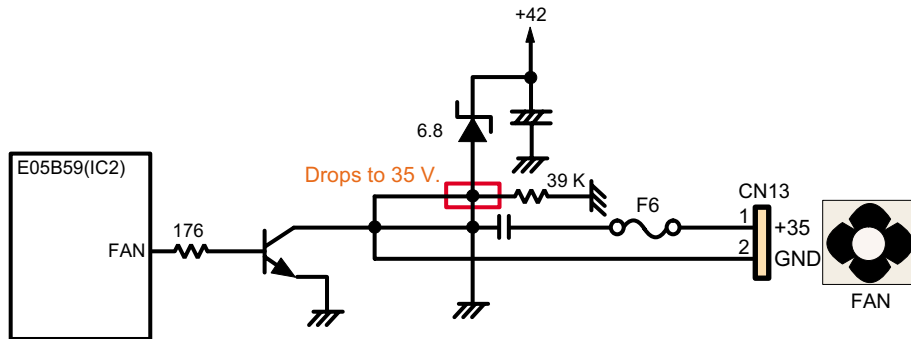

Figure 2-19. Cooling Fan Driver Circuit Block Diagram

Table 2-19. Cooling Fan Control by the ASIC (IC2)

ASIC (IC2, 176- pin) condition	Cooling fan condition
High	(5 VDC) On
Low	(0 VDC) Off

Figure 2-20 shows the main routine of the cooling fan drive.

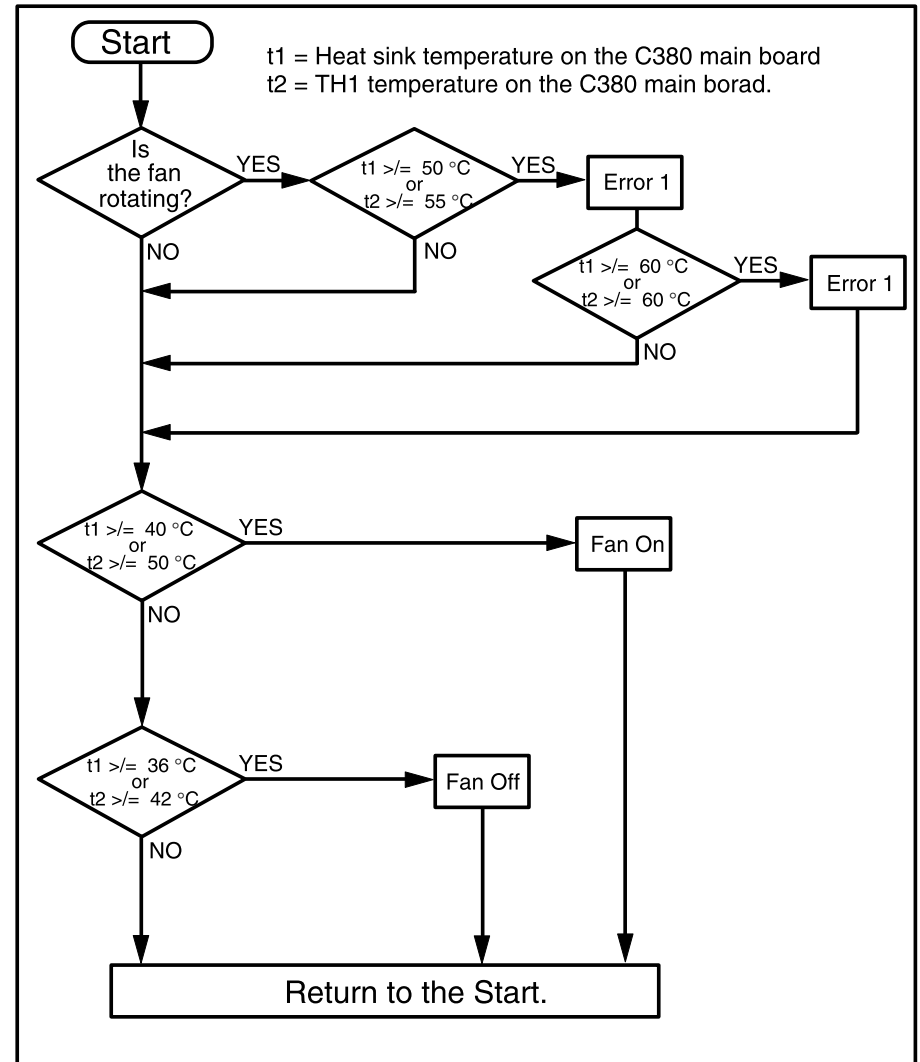

Figure 2-20. Main Routine of the Cooling Fan Drive

Whether or not the cooling fan is driven depends on the electrical signals sent from the 2 thermistors (“t1” and “t2” in the figure). The “t1” represents the temperature detected by the thermistor attached to the heat sink on the C380 main board with a screw, while the “t2” represents the one between the printhead pre-driver ICs (IC15 and IC16) on the C380 main board. Table 2-20 shows the thermistor condition and corresponding fan operation.

Table 2-20. Conditions for Driving the Cooling Fan

Thermistor condition	Cooling fan: Operating	Cooling fan: Stops operating.
t1 and t2 have detected temperatures.	$t1 \geq 40\text{ °C}$ or $t2 \geq 50\text{ °C}$	$t1 \geq 36\text{ °C}$ or $t2 \geq 42\text{ °C}$

Even while the printer is in idle status, the thermistors continue to detect temperatures every 2 seconds for the cooling fan operation. However, 2 error status conditions can be detected in the main routine, since air may not cool down if the fan is defective or the ventilation grill is clogged.

[Error 1]

The printer does not stop printing but continues to print by lowering the drive frequency. For instance, the printer normally prints with the head drive frequency of 14.4 K Hz to perform 1440-dpi print (horizontal) at 200 cps (CR speed). In the error condition, however, the printer can lower the head drive frequency to 7.2 K Hz by reducing CR speed to 100 cpi. Note the printer actually performs printing at 1/3 duty / 1-pass of a normal speed.

[Error 2]

The printer stops printing. In this condition, the temperature at the junction of the power transistor for trapezoidal waveform production and the trapezoid waveform production IC (pre-driver) has risen to the limit (which means the thermistors have detected over 60 °C at both t1 and t2), and the printer generates a fatal error after stopping printing

completely. Therefore, this printer specifically shows a fatal error on the control panel when detecting abnormal temperatures in addition to the following 2 common conditions.

1. Failure in CR home position detection:
This failure can be caused by one of the following 4 reasons:
 - CRHP sensor itself is defective.
 - There is a deficiency in the circuit.
 - Incorrect PG adjustment
 - CR motor is defective
2. Failure in ASF home position detection:
This failure can be caused by one of the following reasons:
 - ASF sensor itself is defective.
 - There is a deficiency in the circuit.
 - ASF is damaged.
 - Pump/ASF motor is defective.

2.3.8 ASF Solenoid Driver Circuit

A planetary gear is used in the gear train which switches between paper feed operation from the ASF and pump operation. The switching action is enabled by the solenoid. See Table 2-21 and Figure 2-21 which show ASF solenoid specifications and the ASF solenoid control circuit block diagram, respectively.

Table 2-21. ASF Solenoid Specifications

No.	Items	Specifications
1	Type	Single-phase DC solenoid
2	Drive voltage	42 VDC \pm 5%
3	Coil resistance	588 Ω \pm 10% (at 20 °C)
4	Induction	0.98 N (100 gf) or more

Table 2-22 shows the ASIC's (IC2) conditions for driving the ASF solenoid.

Table 2-22. Conditions for Driving the ASF Solenoid

ASIC's (IC2, 83-pin) condition	Solenoid's condition
High (5 VDC)	Inducting
Low (0 VDC)	Non-inducting

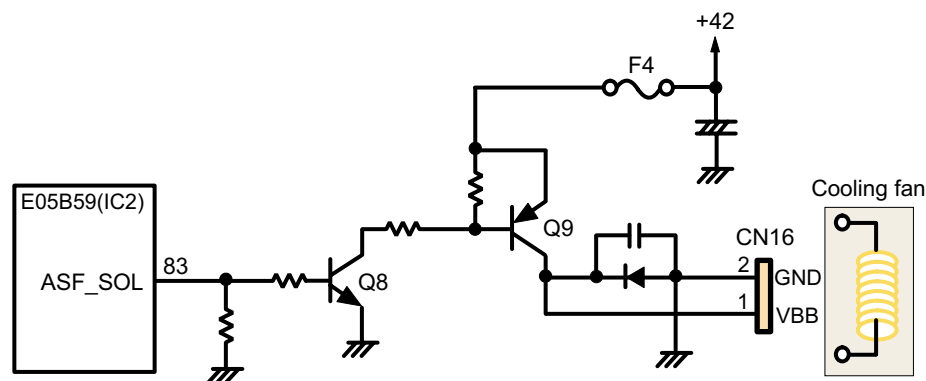

Figure 2-21. ASF Solenoid Control Circuit Block Diagram

2.3.9 EEPROM Control Driver Circuit

Data for various factory-adjustment items is stored in the EEPROM (IC7) on the C380 main board. The size of the EEPROM is 2 K bit since various types of dots are available with this printer and memory allocated for the ink consumption counter is accordingly large.

When the printer is turned on, data stored in the EEPROM is transferred to the D-RAM by the ASIC (IC3). In the D-RAM, the ASIC controls various adjustment values, total ink consumption, and current ink usage condition for each color, and the printer prints depending on these values. When the printer is turned off, the data and adjustment values accumulated and controlled in the D-RAM are written back into the specific addresses in the EEPROM under the ASIC's control. Information is transmitted between the ASIC (IC3) and the EEPROM in the serial data format.

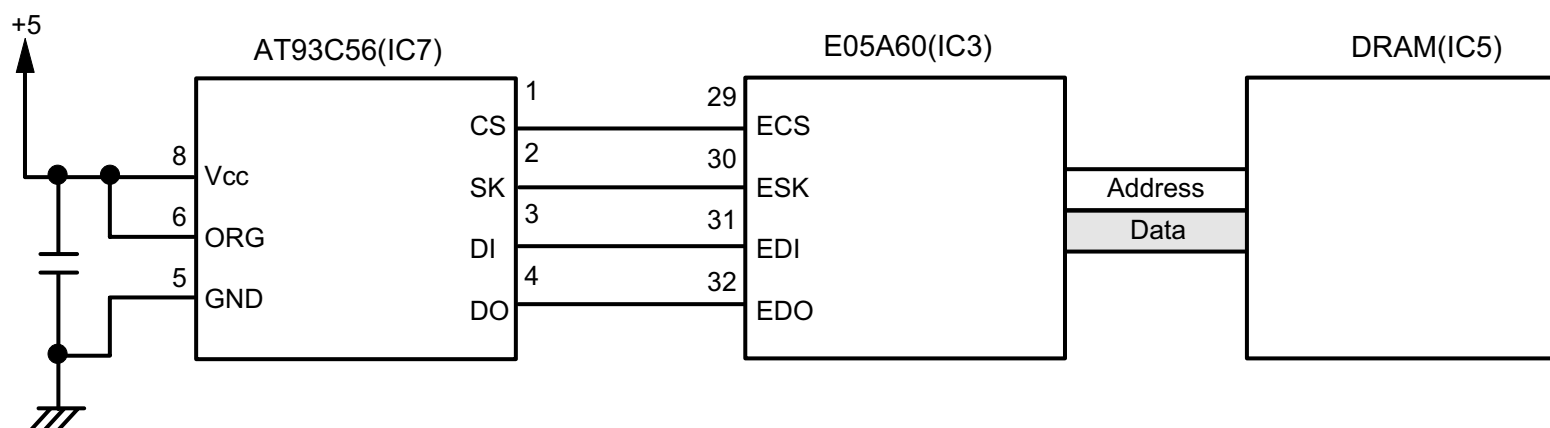

Figure 2-22. EEPROM Control Circuit Block Diagram

CHAPTER

3

TROUBLESHOOTING

3.1 Overview

This chapter describes how to troubleshoot problems. It consists of the sections shown in the flowchart below. When identifying and troubleshooting problems, be sure to proceed to the correct section specified in the flowchart.

Following sections show detailed information on each step in the flowchart. Be sure to perform troubleshooting without neglecting the correct order specified in each section.

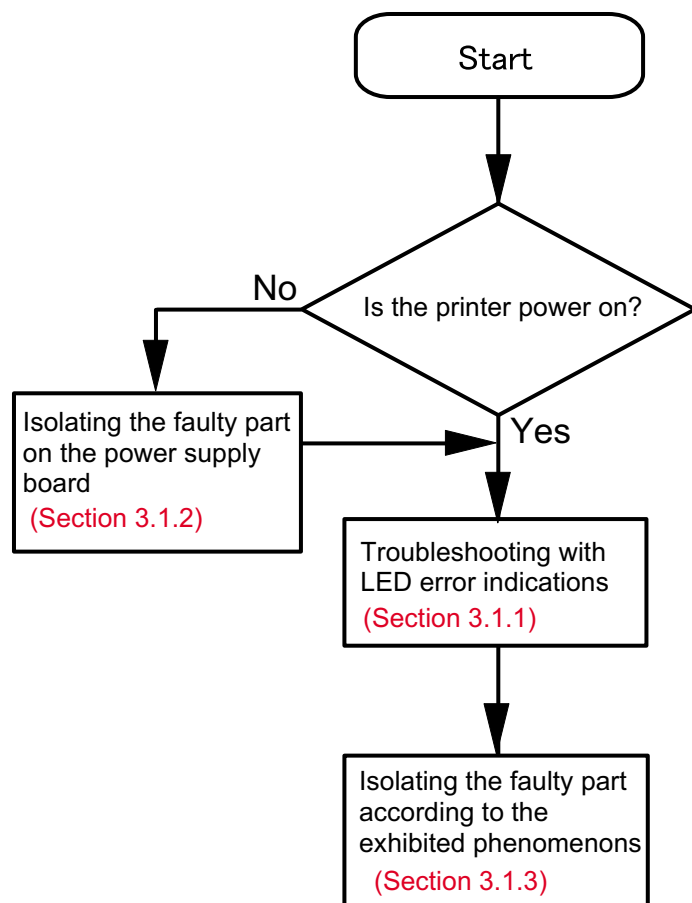

Figure 3-1. Troubleshooting Flowchart

3.1.1 Troubleshooting with LED Error Indications

This section describes how to troubleshoot the problem when the printer indicates an error at power on and can not print. The Stylus Color can detect the following seven errors and indicates them with the LEDs, as shown below.

Table 3-1. Error Indication with the LEDs

Error Condition	Corresponding Combination of the LED Condition			
	Power	Ink Out (Black)	Ink Out (Color)	Paper Out
Paper Out Error	On	---	---	On
Paper Jam Error	---	Off	Off	Blink
No I/C or Ink Out (Black) Error	---	On	---	---
No I/C or Ink Out (Color) Error	---	---	On	---
Maintenance Error	Blink	Blink	Blink	Blink
Fatal Error	Blink	On	On	Blink
Double Feed Error	---	---	---	On

NOTE: “---” means the LED is not affected by the error condition.

See the following tables which show the error conditions and corresponding possible causes.

Table 3-2. Error Condition and the Possible Causes

No.	Error Condition	Possible Causes
1	Paper Out Error or Double Feed Error (Refer to Section 3.1.1.1.)	1. Failure in paper feeding
		2. Connector for the PE sensor is disconnected.
		3. The PE sensor actuator is acting improperly. The sensor base is not fixed properly.
		4. The PE sensor is defective.
		5. ASF is damaged.
2	Paper Jam Error (Refer to Section 3.1.1.2.)	1. The paper in use is longer than specified.
		2. The encoder at the back of the carriage is covered with dust.
		3. The encoder at the back of the carriage is almost dislocated. If it has completely come off, a fatal error occurs.
		4. The PE sensor remains on because it is covered with paper debris or dust.
		5. The PE sensor actuator is not acting properly. The sensor base is not fixed properly.
		6. The PE sensor is defective. The encoder is defective.
		7. The ASF is not installed properly. The paper load sub roller is not fixed properly.

Table 3-3. Error Condition and the Possible Causes (continued)

No.	Error Condition	Possible Causes
3	NO I/C or Ink Out Error (Refer to Section 3.1.1.3.)	1. The counter is not showing the actual remaining ink level.
		2. Ink cartridge sensor actuator is not acting properly.
		3. The micro switch is not mounted correctly. The connector (green) is disconnected.
		4. The connector (green, 3-pin) on the small board directly attached to the printhead surface side is disconnected. Note the connector (green, 4-pin) is irrelevant as it is for the encoder.
		5. The micro switch is defective.
		6. The value for the ink consumption counter in the EEPROM is destroyed.
		7. Ink cartridge replace command is generated because an abnormal temperature is detected.
4	Maintenance Error (Refer to Section 3.1.1.4.)	Usual waste ink over-flow is requested. Note this error can be cleared by the special function through the control panel operation only.
5	Fatal Error (Refer to Section 3.1.1.5.)	1. The CRHP sensor has come off. The connector for the CRHP sensor is disconnected.
		2. The encoder belt has come off. The encoder belt is not placed through the encoder located at the back of the carriage.
		3. The ASF sensor has come off. The connector for the ASF sensor is disconnected.
		4. The coil for the CR motor has burnt.
		5. The coil for the PF motor has burnt.
		6. The lever fixing the planetary gear has come of the frame. The tension spring is dislocated.
		7. Coil for the pump/ASF motor has burnt.
		8. The coil for the ASF solenoid has burnt.
		9. The CRHP sensor is defective.
		10. The ASF sensor is defective.

3.1.1.1 Remedies for Paper Out Error

This section provides check points and corresponding actions which are necessary when the Paper Out Error problem has occurred because of either of the following reasons:

- Paper is set in the ASF hopper but not fed.
- Paper is fed but not detected by the printer.

Be sure to follow the steps in the order described in the tables.

NOTE: If the finding for the question is Yes, take the action described in the right column. If "No", proceed to the next step.

Table 3-4. Remedies for Paper Out Error

Step	Check point	Actions
1	Is no paper loaded?	<p>Set a cleaning sheet in the ASF up side down. Then holding the top edge, press the Load/Eject button, and the micro pearl on the paper load roller (a semicircular roller) surface is removed. To remove severe smear, staple a cloth moistened with alcohol to a post card and clean the roller in the same manner.</p> 
2	Is the connector for the PE sensor disconnected?	<p>Connect the connector (yellow, 3-pin) for the PE sensor.</p>  <p>Bottom view of the printer mechanism</p> <p>Connector for the PE sensor</p> <p>Tension spring</p>
3	<ul style="list-style-type: none"> Is the PE sensor actuator acting improperly? Is the sensor base floating? 	<ul style="list-style-type: none"> Using your hand, try activating the actuator in the same condition as it is detecting incoming paper. Then release the actuator and check if the actuator automatically returns to its original position with the tension of the spring. Referring to the illustration above, check that the sensor base is securely installed to the frame. If the sensor base is floating or installed insecurely, instal it securely.

Table 3-5. Remedies for Paper Out Error (continued)

Step	Check point	Actions
4	Is The PE sensor defective?	<p>Measure the voltage at the yellow 3-pin connector on the relay board by activating the actuator manually to check that the voltage is correct as follows.</p> <p>The actuator is activated: 2.4 V or more The actuator is released: 0.7 V or less</p> 
5	Is the ASF damaged?	<p>Hand-rotate the shaft in the ASF in the paper feed direction and check if the hopper hops out every time you rotate the shaft.</p> <p>NOTE: Even though the ASF sensor is in the proper condition for detecting the HP sensor, If the hopper is not operating at the correct timing for paper feeding, paper is not loaded. Therefore, if the ASF sensor is working without this correct combination, reassembly or replace the ASF.</p>

3.1.1.2 Remedies for the Paper Jam Error

This section includes the check points and corresponding actions which are necessary when the Paper Jam Error constantly occurs when the printer is turned on or feeding paper.

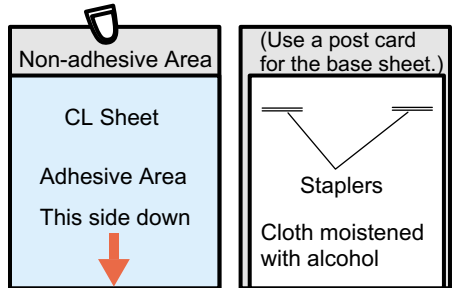
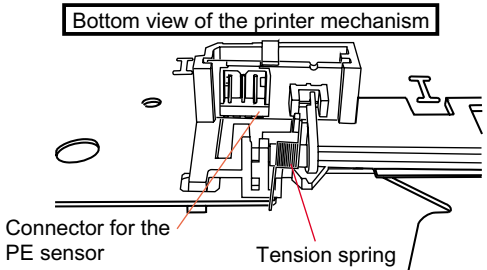
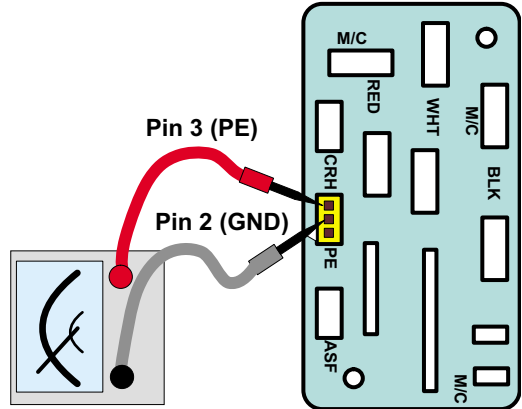
Be sure to follow the steps in the order described in the tables.

NOTE: If the finding for the question is Yes, take the action described in the right column. If “No”, proceed to the next step.

Table 3-6. Remedies for Paper Jam Error

Step	Check Points	Actions
1	Is the paper length beyond the specifications?	Instruct the user that the Paper Jam Error occurs if paper whose length is beyond the specifications is used.
2	Is the encoder located at the back of the CR covered with dust?	Check if there is any dust or paper debris lodged between the parts of the encoder (a transmission type photo sensor) located at the back of the carriage.  A technical diagram of the carriage unit. It shows a yellow linear scale (encoder belt) running horizontally across the carriage. Below it is the encoder. The carriage unit is shown in a perspective view from the side.
3	Is the encoder belt nearly dislocated from the encoder?	Referring to the illustration above, check if the encoder belt is nearly dislocated from the encoder.
4	Is the PE sensor always on because of the paper debris or dust accumulated over the sensor.	Viewing the PE sensor from the front, check that the actuator is the correct position: the actuator falls in the cutout without any paper.  A technical diagram showing the PE sensor assembly and PF roller. The PE sensor assembly is shown in a perspective view from the front. The PE Sensor Actuator is a small rectangular component. The PE Paper Guide Assembly (Right) and PF Roller are also shown. Red lines point to the PE Sensor Actuator, PE Paper Guide Assembly (Right), and PF Roller.

Table 3-7. Remedies for Paper Jam Error (continued)



Step	Check Points	Actions
5	<ul style="list-style-type: none"> Is the PE sensor actuator acting improperly? Is the sensor base floating? 	Referring to Step 3 in Section 3.1.1.1 "Remedies for Paper Out Error", check the sensor condition.
6	<ul style="list-style-type: none"> Is the PE sensor defective? Is the encoder defective? 	<p>Referring to Step 4 in Section 3.1.1.1 "Remedies for Paper Out Error", check the sensor condition. Then, verify the encoder sensor condition by checking the following points for proper connection and electrical continuity, since checking the signal directly from the encoder is impossible.</p> <ol style="list-style-type: none"> 1. Connection of the connector 1 2. Connection of the connector 2 3. Electrical continuity of the cable.  <p>Carriage viewed from the back</p> <p>Head surface</p> <p>Connector 1</p> <p>Connector 2</p> <p>Check for continuity.</p>

Table 3-8. Remedies for Paper Jam Error (continued)

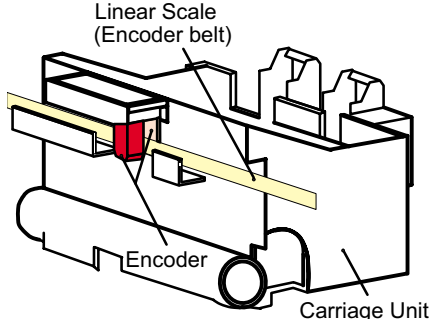
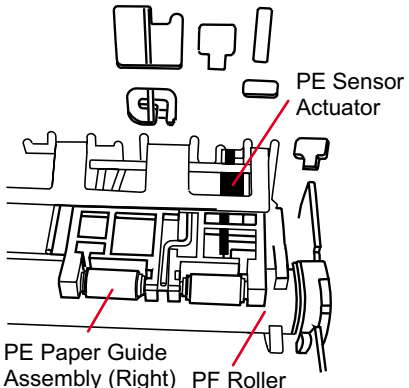
Step	Check Points	Actions
7	<ul style="list-style-type: none"> Is the ASF installed improperly? Is any of the paper load sub rollers fixed improperly? 	<ul style="list-style-type: none"> Check the ASF installation at the following 2 points: View A and View B in the figure below.    <ul style="list-style-type: none"> Viewing the printer from the back, check that all of the six torsion springs securing the paper load sub rollers are properly installed.  <p>View B</p> <p>View A</p> <p>Protrusion is set in here.</p> <p>View B</p> <p>Disconnected</p> <p>View A</p> <p>Top Frame</p> <p>Tension Spring</p>

3.1.1.3 Remedies for No I/C and Ink Out Errors

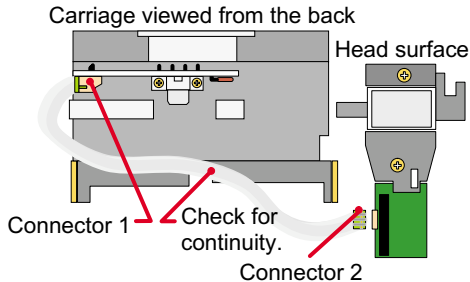
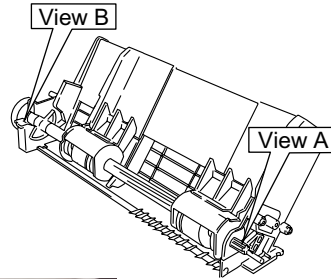
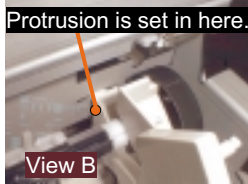
This section includes the check points and corresponding actions which are necessary when the black ink (or color ink) LED comes on or blinks at power on despite the ink cartridge has been replaced with a new one. Be sure to follow the steps in the order described in the tables.

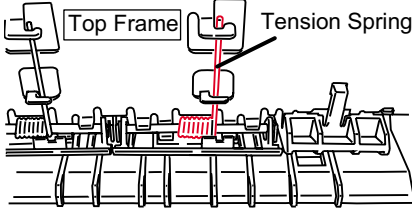
NOTE: If the finding for the question is Yes, take the action described in the right column. If "No", proceed to the next step.

Table 3-9. Remedies for No I/C and Ink Out Errors

Step	Check Point	Actions
1	Does the counter value mis-match the actual remaining ink level?	<p>The ink consumption counter, separately set for black and color ink, adds up points according to ink weight used to form one dot. This counter is reset (the value returns to zero) when the I/C replacement sequence is performed. If the counter is reset for any other purposes, the following adversities will occur.</p> <ol style="list-style-type: none"> 1. Enough ink is remaining in the cartridge, but the printer shows the Ink low or Ink end condition and can not continue to print. 2. Ink has run out but the printer continues to print and starts false firing, which damages the printhead. <p>Explain the situation to the user well, and replace the I/C with a new one.</p>
2	Is the ink cartridge sensor actuator acting improperly?	<p>Turn the both actuators (eight and left) manually and check that they properly push the micro switches. Then, also check that the actuators return to their normal conditions shown in the figure below automatically.</p> <div style="text-align: center;">  <p>The diagram shows the internal mechanism of the ink cartridge sensor. It features two actuators, labeled 'Actuator 1' and 'Actuator 2', which are connected to micro switches. The actuators are shown in a state where they are pushing the micro switches. The labels 'Actuator 1' and 'Actuator 2' are positioned below the actuators, and 'Micro Switches' is positioned above the switches. The diagram is a close-up photograph of the printer's internal components, with the actuators and switches highlighted in orange and blue.</p> </div>

Table 3-10. Remedies for No I/C and Ink Out Errors (continued)

Step	Check Point	Actions
3	Is the micro switch fixed improperly? Is the connector (green) disconnected?	<p>If the micro switch is not properly attached, the actuators possibly fail to touch the micro switch. Therefore, check that the micro switch is securely attached to the carriage by the hooks.</p> 
4	Is the connector (green, 3-pin) disconnected from the small board which is directly attached to the head surface side?	<p>Remove the printhead and check if the connector (green, 3-pin) is disconnected from the small board at the bottom of the printhead.</p> <p>Note: The white 4-pin is irrelevant as it is for the encoder.</p>
5	Is the micro switch defective?	<ol style="list-style-type: none"> Keeping the left micro switch pressed down, place the probes of the tester to the middle and left pins to check for electrical continuity. Keeping the right micro switch pressed down, place the probes of the tester to the middle and right pins to check for electrical continuity. 

Table 3-11. Remedies for No I/C and Ink Out Errors (continued)

Step	Check Point	Actions
6	Is data in the EEPROM destroyed?	<p>If the address for the ink consumption information in the EEPROM is garbled and the printer shows the Ink Out (Ink End) error constantly, the printer sets the interface signal "BUSY" to High and stops communication with any other peripheral devices. Therefore, it is effective to replace the I/C with a new one to forcibly overwrite the address with 00H.</p>
7	Is the abnormal temperature detection circuit working?	<p>Since the Stylus Color 980 drives a large number of PZT with a high drive frequency, if the printhead is driven without any ink filled in it, the printhead abnormally heats up and may be damaged as the result. Therefore, this printer monitors and controls the temperature around the printhead more strictly than any other printers do. In case the printer detects abnormal rise in head temperature during printing, it generates the I/C replacement command after the sequence described below.</p> <ol style="list-style-type: none"> Detects an abnormal temperature during printing. Stops printing and begins a head cleaning. (This operation solves the nozzle clogging problem in most cases.) Resumes printing. If detects an abnormal rise in the head temperature again, sets a flag and generates the I/C replacement command. (The Ink LED comes on.) <p>The printer mostly enters this sequence under the following two conditions:</p> <ul style="list-style-type: none"> Ink around the nozzles is severely viscous. (due to removal and reinstallation of the I/C) Ink is leaking from the printhead because of a large impact. <p>The temperature in the printhead actually rises abnormally when half the nozzles in any nozzle row are clogged, or 48 nozzles in any 96-nozzle row are clogged.</p>

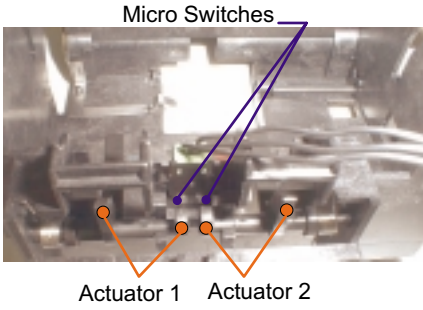
3.1.1.4 Remedies for the Maintenance Error

While the printer is in this error condition, it disables all operations including data communication except for the panel operation specified to clear the error. Therefore, follow the steps described in Table 3-12 to solve the problem.

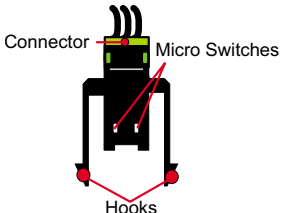
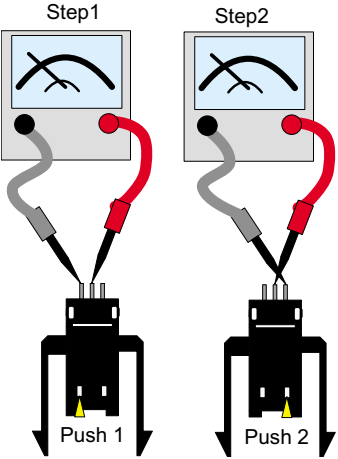
Table 3-12. Remedies for the Maintenance Error

Step	Actions	Correct LED condition
1	Turn the printer on while pressing the Load/Eject and the Cleaning buttons, and the Paper Out LED starts blinking. (Blinks for three seconds.)	The Paper Out LED is blinking.
2	While the Paper Out LED is blinking (for three seconds), press the Cleaning button for ten seconds.	The following three red LEDs are blinking: Ink Out LED (Black), Ink Out LED (Color), and Paper Out LED.

NOTE: During the Step 2, if the Load/Eject button is pressed, the Maintenance Error is not cleared but the EEPROM initialization mode is activated instead. The EEPROM initialization can be used to recover from conditions such as the printer does not accept any data from the PC. The EEPROM initialization mode initializes the following items:

- Accumulated power-off time: The value for the Timer IC is reset.
- CL Timer: The CL timer, which is also called fire-waiting timer, secures the printer specific period of time so bubbles formed around the printhead during a cleaning vanish.
- I/F selection: Selects "Auto", the factory default, from 3 I/F selection items: Auto, Parallel and Option.

3.1.1.5 Remedies for Fatal Error

A fatal error is basically caused by any of the following conditions:

1. The printer does not detect the carriage in the home position.
2. The printer does not detect signals from the linear scale.
3. The ASF sensor does not detect the ASF home position.

The following tables show various causes of the error and corresponding solutions. Be sure to follow the steps correctly to solve the problems.

NOTE: If the finding for the question is Yes, take the action described in the right column. If "No", proceed to the next step.

Table 3-13. Remedies for Fatal Error

Step	Check Point	Actions
1	Has the CRHP sensor come off the printer mechanism frame? Is the connector for the CRHP sensor disconnected?	Check the CRHP sensor visually. Connect the connector properly. Make sure the connector is connected to the indicated position on the relay board. Also, check that there is no dust nor paper debris between the sensor parts. 
2	Has the encoder belt come off?	Referring to step 2 in Section 3.1.2.2, check that the encoder belt is set between the sensor parts. Also check that the sensor is free from dust and paper debris.

Table 3-14. Remedies for Fatal Error

Step	Check Point	Actions
3	Has the ASF sensor come off? Is the sensor for the ASF disconnected?	Referring to the figure below, check that the ASF sensor is attached to the correct position. Check that both connectors 1 and 2 are securely connected. 
4	Has the coil for the CR motor burnt?	Since the CR motor is controlled by the Bipolar system, measure the coil resistance using the tester as shown below. <Resistance: 5.8 Ω ± 10%> Note: Be sure to measure the resistance at two points shown in the figure below. 
5	Has the coil for the PF motor burnt?	Measure the internal coil resistance of the PF motor in the same manner as for the CR motor. <Resistance: 8.1 Ω ± 10%>

Table 3-15. Remedies for Fatal Error (continued)

Step	Check Point	Actions
6	Is the lever securing the planetary gear dislocated from the frame? Has the tension spring come off?	<p>Check if the two hooks securing the planetary gear fixing lever to the Pump/ASF switch mechanism are released from the frame. Also, check the tension spring's condition.</p>  <p><Pump/ASF Switching Mechanism> Pump/ASF Motor Lever Fixing the Planetary Gear Iron Core in the Solenoid Tension Spring</p>
7	Has the coil for the Pump/ASF motor burnt?	<p>Measure the internal coil resistance of the pump/ASF motor in the same manner as for the CR motor (Step 4). <Resistance: 7.0 Ω ± 10%></p>
8	Is the coil for the ASF solenoid burnt?	<p>Referring to the figure below, measure the coil resistance of the solenoid coil using a tester. Note the tester can be used regardless of the polarity. <Resistance: 588 Ω ± 10%></p>  <p>Solenoid</p>

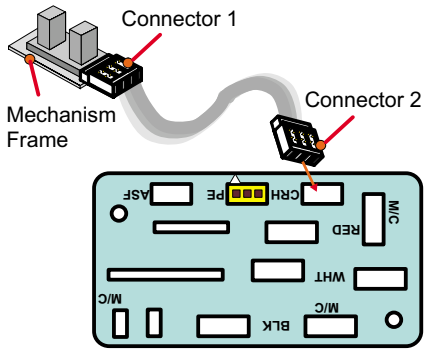
Table 3-16. Remedies for Fatal Error (continued)

Step	Check Point	Actions
9	Is the CRHP sensor defective?	<p>Check for the correct voltages at 3-pin connector shown in the figure below. Turn the printer on and check the voltage is correct as follows:</p> <ul style="list-style-type: none"> When the CR has come in the home position, the voltage rises to 2.4 VDC or higher. When the CR has left the home position, the voltage drops to 0.7 VDC or lower.  <p>To Pin 3 (CRHP) To Pin 2 (GND)</p>
10	Is the ASF sensor defective?	<p>Check for the proper voltage in the same manner as described in the previous step. The ASF connector (3-pin) location on the relay board is also shown in the figure above. The pin configuration is also the same as CRHP sensor. At power on, the ASF reset operation is performed, and the ASF Sensor detects ASF home position.</p>

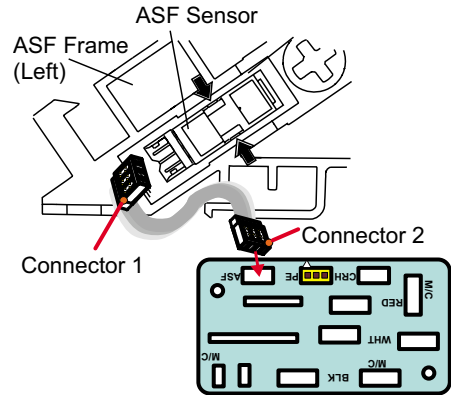
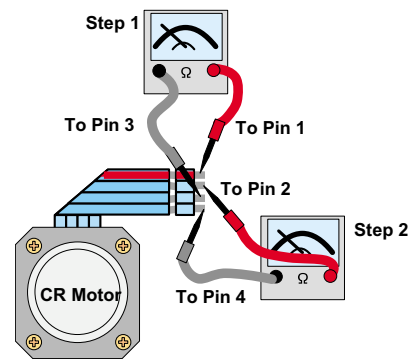
3.1.2 Isolating the Faulty Part on the Power Supply Board

This section explains how to troubleshoot the following problems:

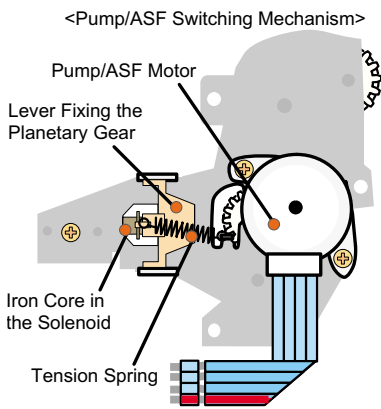
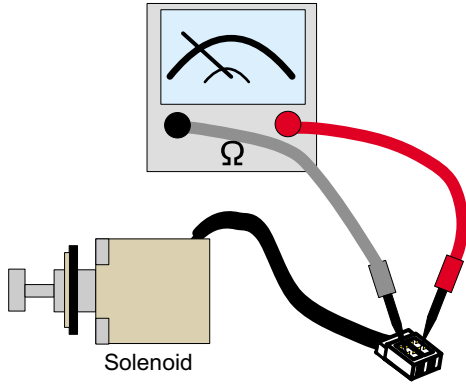
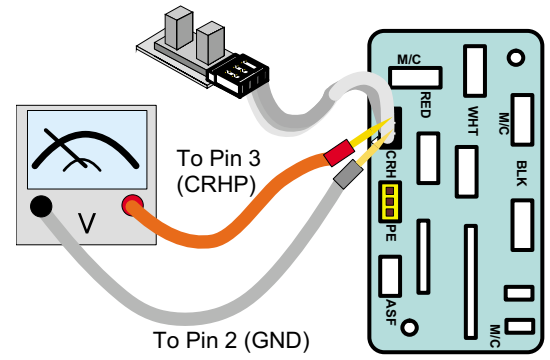
- The printer is turned on, but the initialization is not performed and LED on the control panel do not come on.
- Problems after power on

Be sure to perform troubleshooting in the order specified, because the parts involved are mentioned in the disassembly procedure to facilitate servicing.

Table 3-17. Isolating the Faulty Part on the Power Supply Board

Step	Check Point	Action
1	Is the panel FFC disconnected from the connector on the panel board?	The power switch for this printer is in the secondary side. Therefore, if the FFC does not transfer signals, the printer does not operate despite the power supply board and the main board are properly connected.
2	Is the panel FFC disconnected from the connector (black, 12-pin) on the relay board?	This printer uses the power switch on the secondary side. Therefore, if the FFC does not transfer signals, the printer does not operate despite the power supply board and the main board are properly connected.
3	Is the connector disconnected from the CN15 on the main board?	The reason is the same as above. The panel control FFCs are connected via 1) CN15 on the main board → 2) Relay board → 3) Control Panel.
4	Has the fuse (F1) on the power supply board blown?	Check if the line in the F1 located beside the CN1 on the power supply board has blown.
5	Is CN2 or CN3 on the power supply board disconnected?	Check that the connectors CN2 and CN3, which are used to apply power to the main board, are properly connected.

Table 3-18.

Isolating the Faulty Part on the Power Supply Board (continued)

Step	Check Point	Action
6	Is CN 5 or CN6 on the main board disconnected?	Check that the connectors CN5 and CN6, which are used to input power from the power supply board, are properly connected.
7	Is the choke coil broken?	Viewing the reverse side of the power supply board, check for the proper continuity at the two points indicated in the figure below. 
8	Is the transformer (T1) broken?	Referring to the figure below, check if the transformer is disconnected between the poles. Try every combination in each group marked with a blue box. 

Table 3-19.

Isolating the Faulty Part on the Power Supply Board (continued)

Step	Check Point	Action
9	Is the main switching FET (Q1) defective?	<p>Check the electrical continuity of the switching FET by trying four patterns below. Be sure to pay attention to the polarity. If the main switching FET is good, the findings should be as shown under the figure.</p> <p>Step 1: Off, Step 2: On, Step 3: Off, Step 4: Off</p>
10	Is the NPN connection transistor defective?	<p>Check the electrical continuity of the NPN connection transistor on the C265 PSB/SE board by trying four patterns below. Be sure to pay attention to the polarity. If the NPN contact transistor is good, the findings should be as shown under the figure. Note the NPN connection transistor is shown in the circuit diagram as described below.</p> <p>Step 1: On, Step 2: Off, Step 3: Off, Step 4: On</p>

Table 3-20.

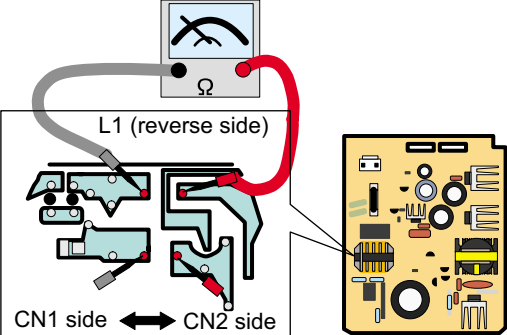
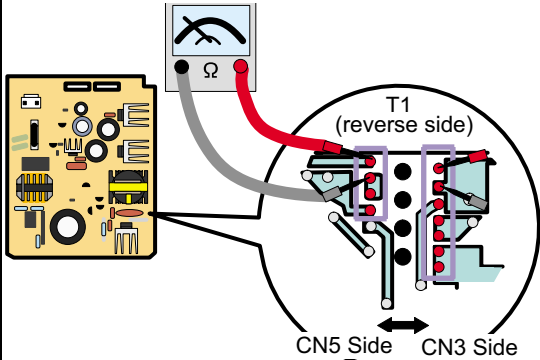
Isolating the Faulty Part on the Power Supply Board (continued)

Step	Check Point	Action
11	Is the PNP connection transistor defective?	<p>Check the PNP connection transistor on the C265 PSB/SE board in the same manner described in the previous step.</p> <p>Step 1: Off, Step 2: On, Step 3: Off, Step 4: On</p>
12	Is the +5 V regulator (IC51) defective?	<p>Check the IC51 for the oscillation waveform (measured by using a oscillo scope) output from the Pin 5. If the output waveform is as shown below, it means the IC51 is working properly.</p> <p>Oscillation waveform</p> <p>5-pin(OSC)</p>

3.1.3 Isolating the Faulty Part according to the Phenomenon

Refer to this section if you could not solve the problem in Section 3.1.1 or Section 3.1.2 or need more information to isolate the cause according to the exhibited phenomenon. The contents mostly cover the problems relating to the C380 Main board and their remedies.

Table 3-21. Phenomena Exhibited

No.	Phenomenon Exhibited	Table to refer to
1	The cooling fan does not rotate. Note the cooling fan does not constantly rotate. Refer to Chapter 2 / Section 2.3.7.	Table 3-22,
2	CR motor does not rotate.	Table 3-23
3	PF motor does not rotate.	Table 3-24
4	pump/ASF motor does not rotate.	Table 3-25, Table 3-26
5	ASF solenoid does not operate.	Table 3-27, Table 3-28
6	Cleaning does not solve the print problem.	Table 3-29 - Table 3-33
7	Ink End Error occurs after the printhead is replaced, so the printhead can not be adjusted.	Table 3-34

Table 3-22. Cooling Fan does not Rotate

Step	Check Point	Action
1	Is the fuse (F6) open?	Place the probes of the tester on the both terminals of the chip fuse (F6) on the C380 Main board. Then check for electrical continuity. F6 is located beside the Q7 which is in front of the cooling fan connector (CN13).
2	Is the transistor (Q7) defective?	<p>Q7 is beside the connector (CN13 for the cooling fan). Since the three terminals for the base, emitter, and collector are not marked, try every pattern below to check for electrical continuity. Be sure to test with the correct polarity. The correct findings are shown under the figure.</p> <p>Step 1: On, Step 2: Off, Step 3: On, Step 4: Off</p>
3	Is the internal coil for the fan motor open?	Replace the Fan unit and then check for the correct operation.
4	Is the C380 Main board defective?	If the cause has not been isolated yet, replace the C380 Main board.

Table 3-23. CR Motor does not Operate

Step	Check Point	Action
1	Getting ready for inspecting waveforms.	<p>The connector used to control the CR motor is indicated in the figure below. Using the oscillo scope, check for the waveform for each phase at the indicated connector. To check the waveform, press the Load/Eject button to attempt to move the carriage. Be sure to leave the cable for the CR motor connected.</p> <p>Phase A, Phase B, Phase /A, and Phase /B from the Pin 1 mark.</p>  <p>NOTE: The GND can be output by placing the probe of the oscillo scope to the tapped hole in the bottom plate on the board with a screw. Note the connector has no ground line since this printer drives the motor with the bipolar system.</p>
2	Check of the waveform and remedies	<p>While trying to drive the CR motor, the waveform output from each phase should be as shown in the figure. If the waveform output from each phase is as shown below, replace the CR motor. If not, replace the IC12 (CR motor driver IC) or C380 Main board.</p>  <p>NOTE: The GND can be output by placing the probe of the oscillo scope to the tapped hole in the bottom plate on the board with a screw.</p>

Table 3-24. PF Motor does not Operate

Step	Check Point	Action
1	Getting ready for inspecting waveforms.	<p>The connector used to control the PF motor is indicated in the figure below. Using the oscillo scope, check for the waveform for each phase output from the indicated connector. To check the waveform, press the Load/Eject button to attempt the ASF paper feeding. Be sure to leave the cable for the PF motor connected.</p>  <p>Phase A, Phase B, Phase /A, Phase /B from the Pin 1 mark</p> <p>NOTE: The GND can be output by placing the probe of the oscillo scope to the tapped hole in the bottom plate on the board with a screw. Note the connector has no ground line since this printer drives the motor with the bipolar system.</p>
2	Check of the waveform and remedies.	<p>While trying to drive the PF motor, the waveform output from each phase should be as shown in the figure. If the waveform output from each phase is as shown in the figure, replace the PF motor. If not, replace the IC11 (PF motor driver IC) or C380 Main board.</p>  <p>NOTE: The GND can be output by placing the probe of the oscillo scope to the tapped hole in the bottom plate on the board with a screw.</p>

Table 3-25. Pump/ASF Motor does not Operate

Step	Check Point	Action
1	Getting ready for inspecting waveforms.	<p>The connector used to control the Pump/ASF motor is indicated in the figure below. Using the oscillo scope, check the waveform for each phase output from the indicated connector. To check the waveform, press the Load/Eject button to attempt the ASF paper feeding. Be sure to leave the cable for the Pump/ASF motor connected.</p>  <p>Phase A, Phase B, Phase /A, Phase /B from the Pin 1 mark</p> <p>NOTE: The GND can be output by placing the probe of the oscillo scope to the tapped hole in the bottom plate on the board with a screw. Note the connector has no ground line since this printer drives the motor with the bipolar system.</p>

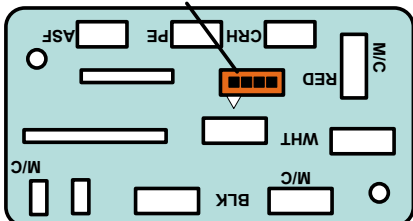
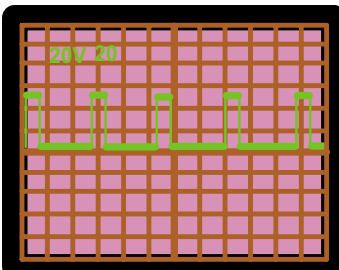
Table 3-26. Pump/ASF Motor does not Operate (continued)

Step	Check Point	Action
2	Check of the waveform and remedies.	<p>While trying to drive the Pump/ASF motor, the waveform output from each phase should be as shown below. If the waveform output from each phase are as shown below, replace the Pump/ASF motor. If not, replace the IC13 (Pump/ASF motor driver IC) or C380 Main board.</p>  <p>NOTE: The GND can be output by placing the probe of the oscillo scope to the tapped hole in the bottom plate on the board with a screw.</p>

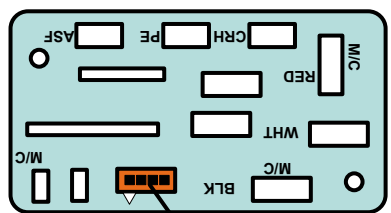
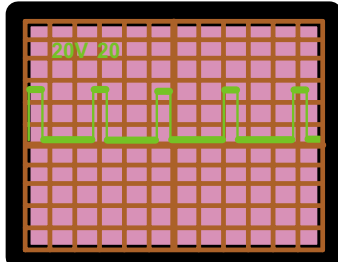
Table 3-27. ASF Solenoid does not Operate

Step	Check Point	Action
1	Is the fuse (F4) open?	Place the probes of the tester on the both terminals of the chip fuse on the C380 Main board, then check for electrical continuity. The F4 is located between CN12 and CN16 and also beside the Q9.
2	Is the transistor (Q8) defective?	Place the probe of the oscillo scope on the collector side of the transistor Q8 on the C380 Main board, then check that 40 VDC is constantly applied. Then press the Load/Eject button and check if the voltage drops to 0 VDC for an instant. If it does, it means the Q8 is working properly. The Q8 is located between CN12 and CN16. 

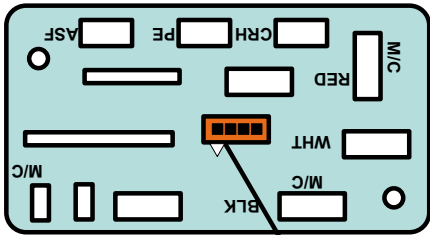
Table 3-28. ASF Solenoid does not Operate (continued)

Step	Check Point	Action
3	Is the transistor (Q9) defective?	Place the probe of the oscillo scope on the emitter side of the transistor Q9 on the C380 Main board, then check that voltage is always 0 VDC. Then press the Load/Eject button and check for an instant change in voltage level from 0 to 40 VDC. If it changes correctly as described above, it means the Q9 is working properly. The Q9 is located beside the CN16. 
4	Is the C380 Main board defective?	If the cause has not been isolated yet in the previous steps, replace the C380 Main board.

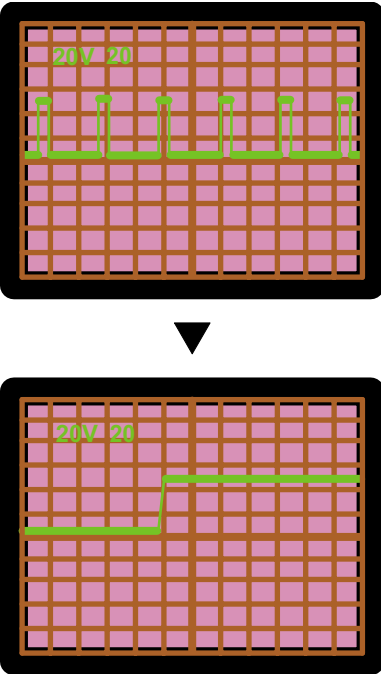
Table 3-29. Cleaning does not Solve the Print Problem

Step	Check Point	Action
1	Repeat the cleaning 7 or 8 times.	Unlike the previous products, the Stylus Color 980 is not equipped with the CL3 (dummy cleaning). Therefore, you can repeat the cleaning every time you press the Cleaning button without running a self-test nor any printing.
2	Trying the initial ink charge operation.	You can repeat the initial ink charge operation in the way described below: 1. Using the exclusive program, reset the initial ink charge flag in the EEPROM. 2. Turn the printer back on. (Refer to Chapter 5 for details.)
3	Reinstalling the printhead FFC.	Remove the upper case and check if the FFCs are properly connected to the CN8 and CN9 on the C380 Main board. Even though they are not installed aslant as shown below, disconnect the FFC once and connect them again, then run a print check.  Check that the connectors are not connected aslant. NOTE: Before reinstalling the FFCs, be sure to remove the frame (in red in the figure) secured to the lower case with two screws. Otherwise, proper continuity may not be guaranteed despite the FFCs look connected without slant.

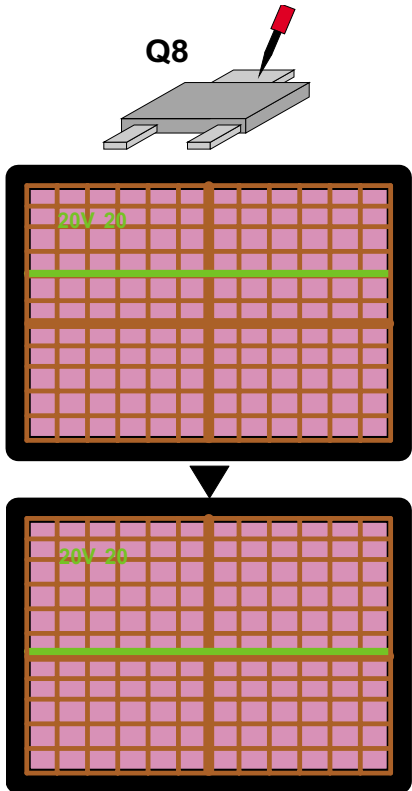
Table 3-30. Cleaning does not Solve the Print Problem (continued)

Step	Check Point	Action
4	Check the cap for any foreign matter, dirt, or damage.	Remove the printer mechanism and release the carriage lock at the back of the printer mechanism to move the carriage unit away from the home position. Then, have a close look at the cap rubber and check for any problem below. 
5	Has the valve cap fallen off?	If a strong impact is applied to the valve cap in the cap unit, it may fall off. Therefore, check that the cap is securely attached to the cap unit. Without this part, ink can not be absorbed. 

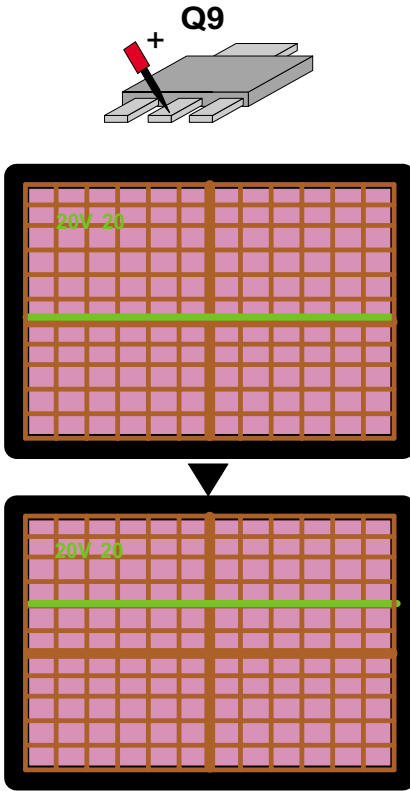
Table 3-31. Cleaning does not Solve the Print Problem (continued)

Step	Check Point	Action
6	Is any ink tube disconnected from the cap unit?	<p>Referring to the figure below, check the following points:</p> <ul style="list-style-type: none"> • Connection between two tubes and the bottom of the cap (Remove the whole cap from the unit to check the connection.) • Connection of each tube and the separator. • Connection of one tube at the bottom of the valve 
7	Is the FFC disconnected from the printhead board?	<p>Remove the printhead unit from the carriage unit, and bring the printhead surface side upward to check that two FFC is properly connected. Even though no slant connection nor disconnection is found, disconnect the FFC once and install them again.</p> 

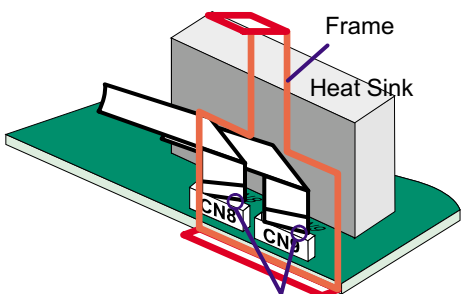
Table 3-32. Cleaning does not Solve the Print Problem (continued)

Step	Check Point	Action
8	Is the head driver transistor defective?	<p>If you see the C380 Main board from the heat sink side, the following four power transistors can be found:</p> <ul style="list-style-type: none"> • Q3 and Q4: Outputs the common voltage for the row A and B (black nozzle rows) • Q5 and Q6: Outputs the common voltage for the row C, D, and E (color nozzles) <p>To check if each pair transistor is working properly, check the trapezoid waveform at the emitter terminal of the charging side (Q3 and Q5). Check the waveform while running a print.</p>   <p>NOTE: Frequency of waveform and voltage level (p-p) varies if printing is performed through the driver. Therefore, as long as the trapezoid waveform is output, the head driver IC is considered good, and the printhead must be replaced in that case.</p>

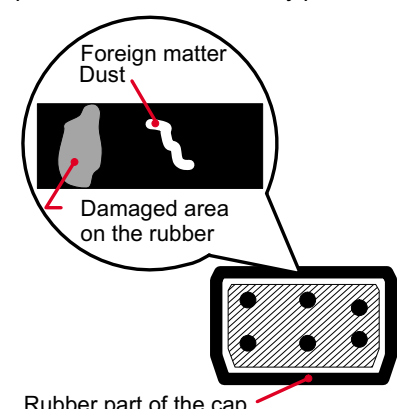
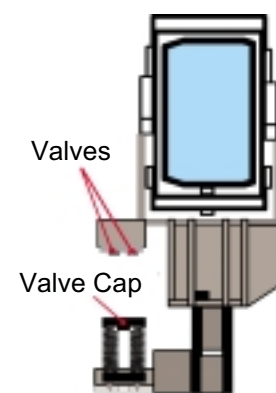
Table 3-33. Cleaning does not Solve the Print Problem (continued)

Step	Check Point	Action
9	Is the head driving pre-driver defective?	<p>If a trapezoid waveform is not output in the previous step, check all the power transistors (Q3 - Q6) for base waveforms. Like the head transistor in Step 8, the power transistors also output trapezoid waveforms, but are input from the pre-driver side.</p>  <p>If the waveform are not output correctly, replace the IC15/16 or C380 Main board. If the waveform is output correctly, replace the corresponding power transistor.</p>

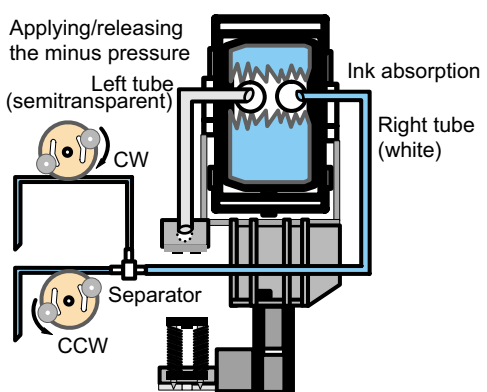
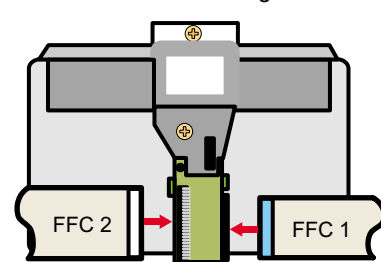
Unlike the previous products, the procedure after head replacement is precisely specified. Therefore, be sure to follow the steps in Table 3-34 exactly. The background of the procedure is explained after the table.

Table 3-34. Ink End Error Occurs after Printhead Replacement

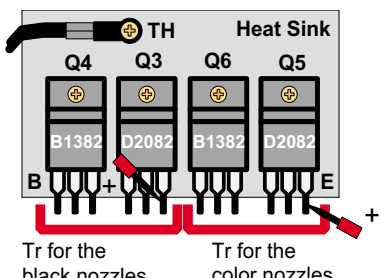
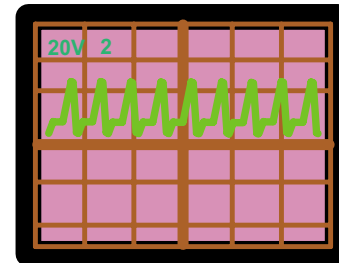
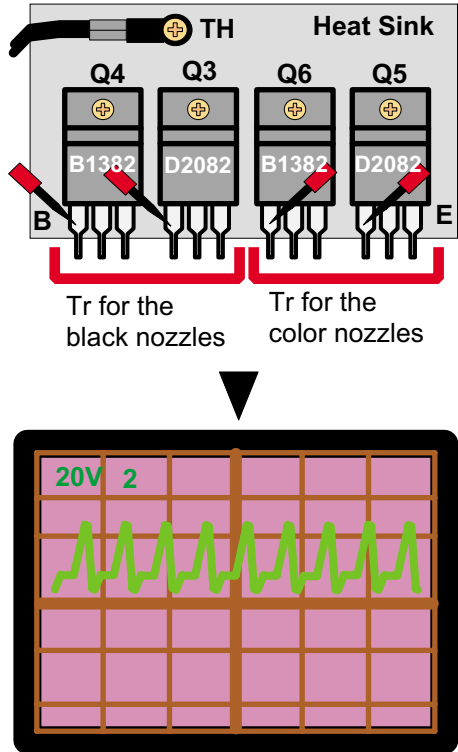
Step	Action
1	Turn the printer power off.
2	Replace the printhead.
3	Turn the printer back on. (The printer is in No Ink Cartridge condition.)
4	Keep the Load/eject button pressed down for several seconds. The printer enters the I/C replacement sequence. (The printer moves to the black ink cartridge replacement position first, then to the color cartridge replacement position if the Load/Eject button is pressed.)
5	Input a 21-digit head IC. (Refer to Chapter 4 "Adjustment" for details.)
6	Perform the initial ink charge operations. (Refer to Chapter 4 "Adjustment" for details.)
7	Perform the head angle adjustment. (Refer to Chapter 4 "Adjustment" for details.)
8	Perform the Bi-D adjustment. (Refer to Chapter 4 "Adjustment" for details.)
9	Perform the Uni-D adjustment. (Refer to Chapter 4 "Adjustment" for details.)

Among the steps, if you do not perform Step 1 to Step 4 in the correct order especially, Ink Cartridge Out error (Ink End error) may occur whenever you replace the printhead. The background of this problem is as follows.

1. Since the printhead equipped with this printer is composed of 480 nozzles and driven by 32.4 KHz, the temperature inside the printhead rises more easily than any other printer. Therefore, the temperatures inside the printhead and on the printhead board must be intensely monitored to avoid damaging the printhead.
2. Rise in the internal temperature of the printhead can cause a fatal damage to the printhead itself. Heat inside the printhead is normally removed as the ink flows inside the printhead.
3. If any of the following conditions occurs, the printhead fails to eject ink properly even though the print data is input.
 - The printhead surface is left away from the home position for a long period of time.
 - The same ink cartridge is remove and installed repeatedly.
 - The table with the printer on it is moved up and down (vertically) intensely.
4. If the ink does not flow properly, the PZT gradually heats up and is eventually hot enough to evaporate the ink inside the cavity (a tank which stores ink).
5. To prevent the printhead from heating up, the 5-channel abnormal temperature detection circuit is included in the nozzle selector (directly attached onto the printhead board). With this circuit, the temperature of each nozzle row (five rows in total) can be independently monitored. (Refer to Chapter 2 / Section 2.3.2.)
6. Once the abnormal temperature detection circuit is active, the printer stops printing and starts a forcible cleaning. This operation cleans the clogged nozzles, and the ink inside the printhead flow properly as a result. At this point, the printer sets the flag in the address for the abnormal temperature detection circuit in the EEPROM to record the first abnormal temperature error.
7. The printer resumes printing with the data transferred.
8. If the printer detects an abnormally high temperature again, the printer regards it as the second abnormal temperature error and enters Ink End Error condition. The printer makes this judgement to avoid following two problems:
 - Since the I/C has been repeatedly removed and reinstalled, the printer fails to evaluate the remaining ink level properly and leaves the I/C in an empty condition.
 - Since the I/C has been repeatedly removed and reinstalled, the ink inside gets stale and can not absorb bubbles and viscous ink into itself.
9. specifically, the nozzle selectors (5 rows in total) used in the mass produced Stylus Color 980 are purchased from either of the following two vendors: EPSON or Sharp. Their ICs slightly differ in the feed back voltage. Therefore, if the installed printhead has the nozzle selector and the 1st digit of the printhead ID in the combination shown in Table 3-35, the printer shows the error at power on and begins a cleaning automatically. Therefore, even though the printer continues to print, it forcibly enters the Ink End error condition for the second time since the flag is already set in the EEPROM address for the abnormal temperature detection circuit.

Table 3-35. Combination which Causes the Error

Nozzle Selector	1st digit of the Head ID
The board is in the Sharp-specific setting.	0
EPSON exclusive printhead	1

For this reason, if you perform the operation in an incorrect procedure such as; Head replacement → I/C replacement → Turning on the printer, the printer starts monitoring the temperatures before the printhead ID on the board is replaced with a new one, then shows the error consequently. On the other hand, if you follow the proper steps; Head replacement → Turning on the printer → proper I/C replacement with a new one, the program allows a data transfer once before printing so you can overwrite the printhead ID.

CHAPTER

4

DISASSEMBLY AND ASSEMBLY

4.1 Overview

This chapter describes procedures for disassembling the main components of EPSON Stylus Color 980. Unless otherwise specified, disassembly units or components can be reassembled by reversing the disassembly procedure. Therefore, no assembly procedures are included in this chapter. Precautions for any disassembly or assembly procedure are described under the heading “CHECK POINT”. Any adjustments required after disassembling the units are described under the heading “REQUIRED ADJUSTMENT”.

4.1.1 Precautions for Disassembling the Printer

See the precautions given under the heading “WARNING” and “CAUTION” in the right column and the following page, respectively, when disassembling or assembling EPSON Stylus Color 980.



- **Disconnect the power cable before disassembling or assembling the printer.**
- **Wear protective goggles to protect your eyes from ink. If ink gets in your eye, flush the eye with fresh water and see a doctor immediately.**
- **If ink comes into contact with your skin, wash it off with soap and water. If irritation occurs, contact a physician.**
- **A lithium battery is installed on the main board of this printer. Be sure to observe the following instructions when serving the battery:**
 - Keep the battery away from any metal or other batteries so that electrodes of the opposite polarity do not come in contact with each other.
 - Do not heat the battery or put it near fire.
 - Do not solder on any part of the battery. (Doing so may result in leakage of electrolyte from the battery, burning or explosion.) The leakage may affect other devices close to the battery.)
 - Do not charge the battery. (An explosive may be generated inside the battery, and cause burning or explosion.)
 - Do not dismantle the battery. (The gas inside the battery may hurt your throat. Leakage, burning or explosion may also result.)
 - Do not install the battery in the wrong direction. (This may cause burning or explosion.)

CAUTION



Danger of explosion if the battery is incorrectly replaced. Replace only with the same or equivalent type recommended by the manufacturer. Dispose of used batteries according to government laws and regulations.

CAUTION



Risque d'explosion si la pile est remplacée incorrectement. Ne remplacer que par une pile du même type ou d'un type équivalent recommandé par le fabricant. Eliminer les piles déchargées selon les lois et les règles de sécurité en vigueur.

CAUTION



- Never remove the ink cartridge from the carriage unless the manual specifies to do so.
- When transporting the printer after the ink cartridge has been installed, be sure to pack the printer for transport without removing the ink cartridge.
- Use only recommended tools for disassembling, assembling or adjusting the printer.
- Apply lubricants and adhesives as specified. (See Chapter 6 for details.)
- Make adjustments specified when you disassemble the printer. (See Chapter 4 for details.)

4.2 Disassembly Procedures

The flowchart below shows procedures for disassembly.

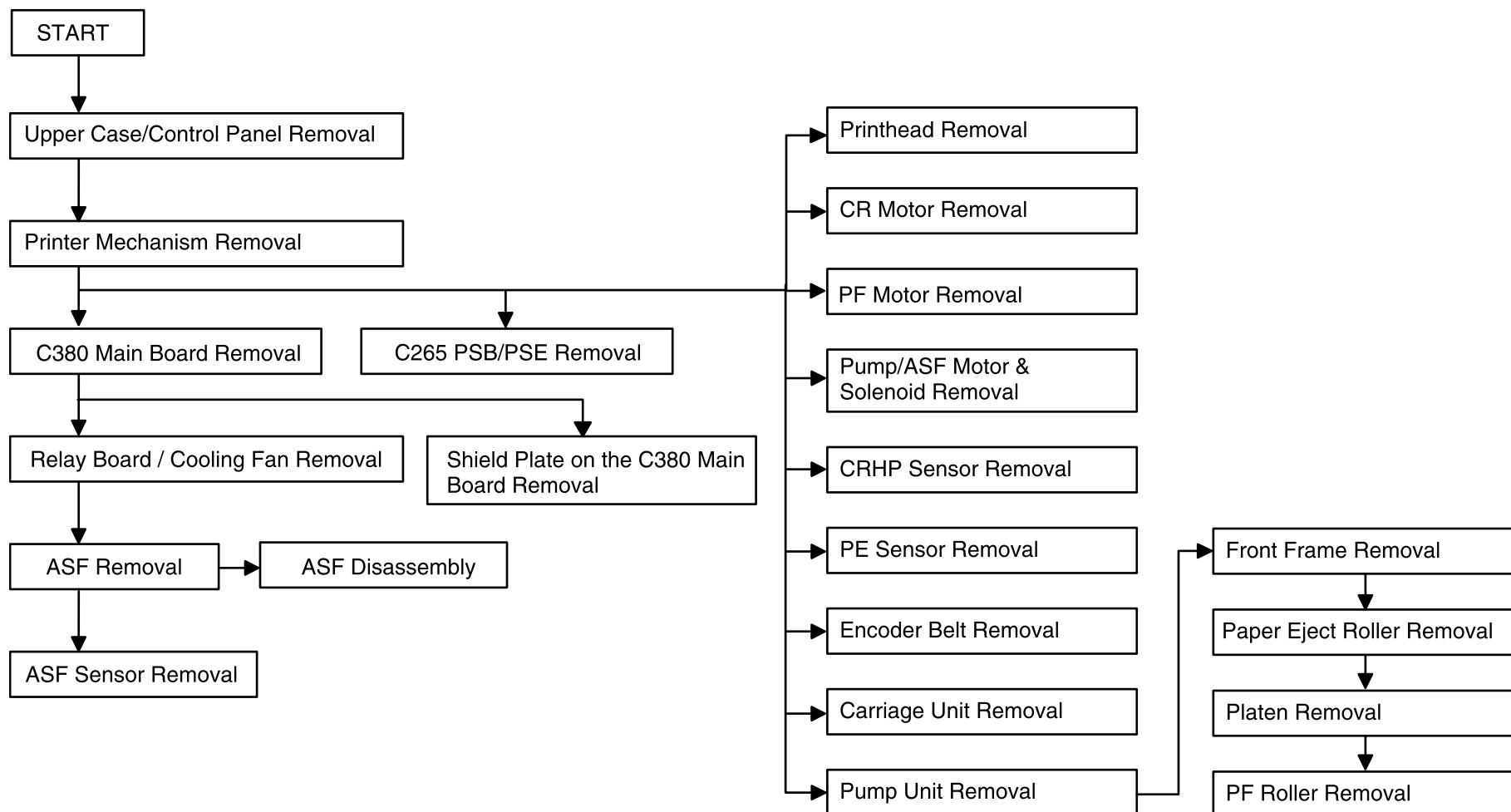

Figure 4-1. Disassembly Flowchart



If you have replaced specified parts, you must make necessary adjustments. See the following tables which shows the parts removed/replaced and corresponding adjustments required, and perform adjustments in the correct order. (See Chapter 5 “Adjustment” for detailed procedures.)

Table 4-1.
Removed/Replaced Parts and Corresponding Adjustments

Actions taken	Step	Corresponding adjustment required
Printhead	1	Install a new I/C in the I/C replacement sequence.
	2	Head Actuator Voltage ID Input
	3	Ink Charge Flag Reset
	4	Head Angular Adjustment.
	5	Bi-Directional Adjustment
C380 Main board	1	Head Actuator Voltage ID Input
	2	Bi-Directional Adjustment
CR shaft	1	Remove the Printhead and CR Unit.
	2	Remove the oil pad. (Refer to Chapter 6.)
	3	Clean and lubricate the carriage guide shaft.
	4	Reinstall the printhead and the CR Unit.
	5	Perform the Parallelism adjustment.
	6	Enter the I/C replacement sequence to install a new I/C and make sure it is completed.
	7	Ink Charge Flag Reset
	8	Head Angular Adjustment
	9	Bi-Directional Adjustment
Waste Ink Pad	1	Clear the protection counter value
CR Motor	1	Bi-Directional Adjustment
Program ROM replacement	1	Head Actuator Voltage ID Input
	2	Bi-Directional Adjustment

4.2.1 Upper Case and Control Panel Removal

1. Remove the sheet guide.
2. Open the upper case.
3. Open the output tray.

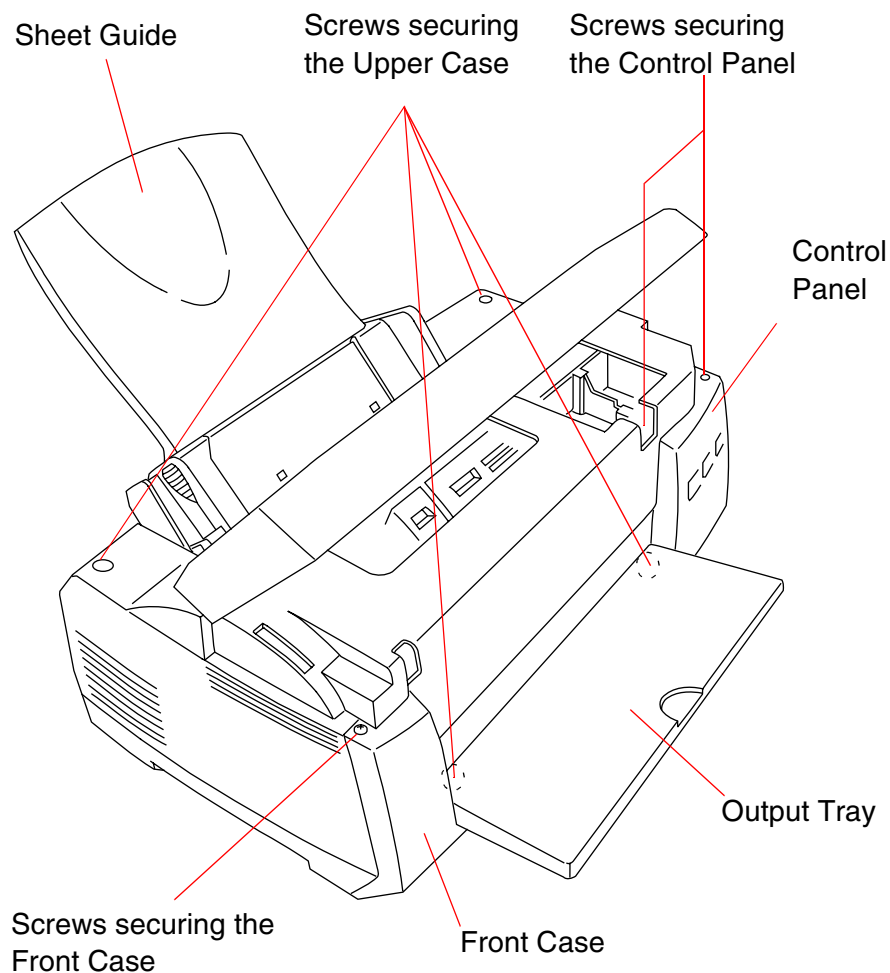

Figure 4-2. Upper Case Removal

4. Remove one screw securing the front case (on the left) to the printer mechanism, then pull the front case forward and remove it from the printer.
5. Pull the output tray to the left and remove it.
6. Remove two screws securing the control panel to the printer mechanism to release the control panel. Then disconnect the FFC from the control panel and remove the control panel from the printer.
7. Remove four screws securing the upper case. When assembling, note the only CBS Tight screw among four must be used at the rear right of the upper case.
8. Lift up the front edge of the upper case, then remove the whole case by tilting it along the ASF.

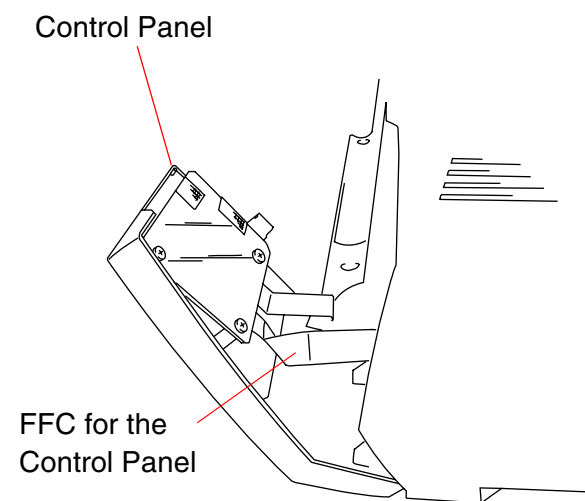

Figure 4-3. Control Panel Removal

4.2.2 Printer Mechanism Removal

1. Remove the upper case. (See Section 4.2.1.)
2. Unlock the cable clamp on the relay board, then take all harnesses out of the cable holder.

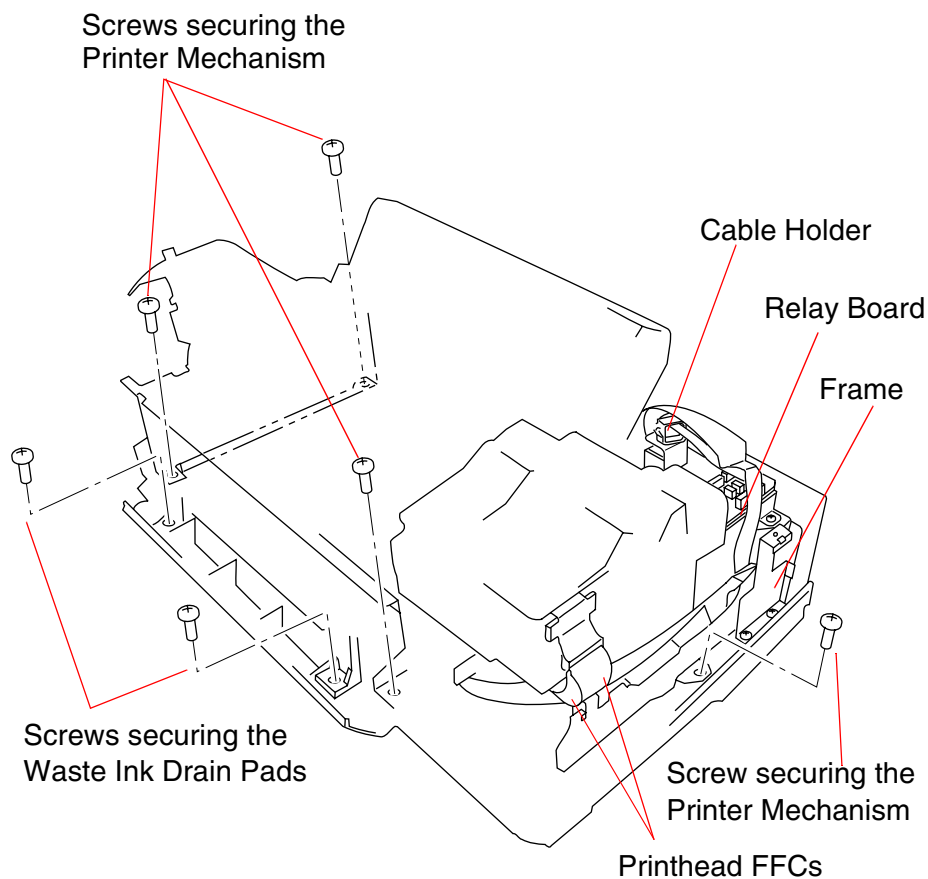

Figure 4-4. Printer Mechanism Removal

3. Disconnect the following connectors from the relay board. (The connectors to be disconnected are colored red in Figure 4-5.)



When assembling, be sure to connect the connectors properly as shown in Figure 4-5.

- 19-pin FFC (used to supply sensors with power and to send condition detection signals)
- 2-pin connector for driving the solenoid
- Connector for ASF
- Connector for PF motor
- Connector for Pump/ASF motor
- Connector for PE sensor
- Connector for CR motor
- Connector for CRHP (Carriage Home Position) sensor

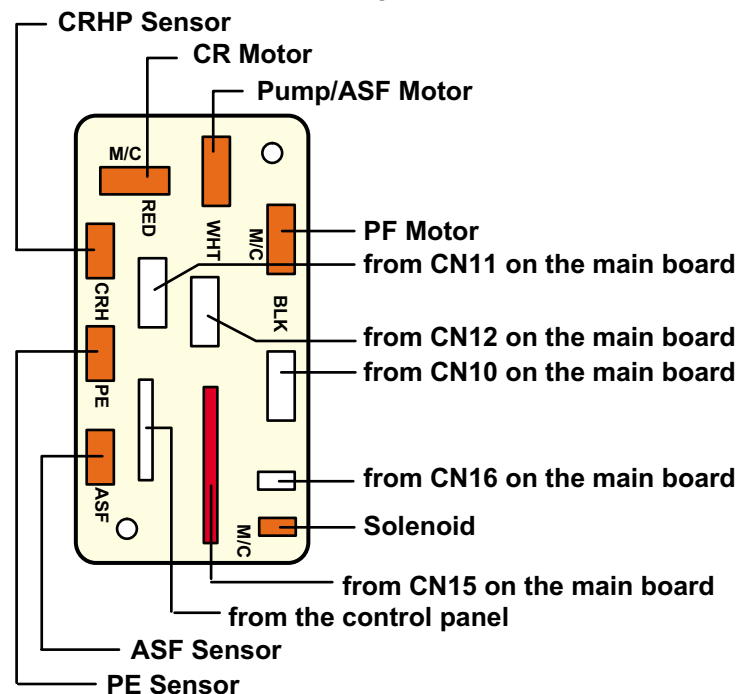

Figure 4-5. Connector Location

4. Remove two screws securing the waste ink drain pad cover to the lower case and remove it.
5. Remove four screws securing the rear case to the stay on the C380 Main board.

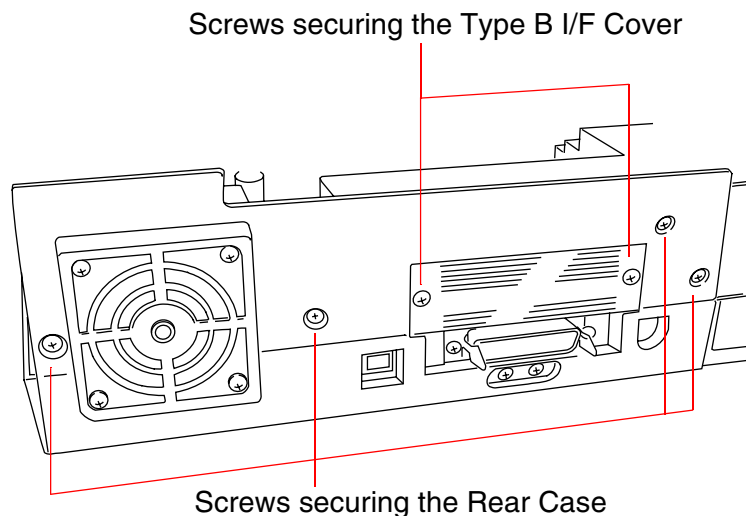

Figure 4-6. Rear case Removal

6. Remove two screws securing the Type B interface cover to the printer, and remove the rear case.
7. Remove one screw securing the frame to the shield plate on the C380 Main board and another two screws securing the frame to the lower case then remove the frame. (See Figure 4-4)
8. Disconnect two printhead control FFCs from the C380 main board.
9. Remove four large screws securing the printer mechanism to the lower case, and remove the printer mechanism.



- After replacing the Waste Ink Pads, perform any necessary adjustments. (See Table 4-1)
- When mounting the four screws, do not fasten them excessively, or the tapped areas in the lower will be damaged.

4.2.3 C380 Main Board Unit Removal

1. Remove the printer mechanism. (See Section 4.2.2.)
2. Remove one screw securing the C380 Main board unit to the shield plate on the C265 PSB / PSE board.

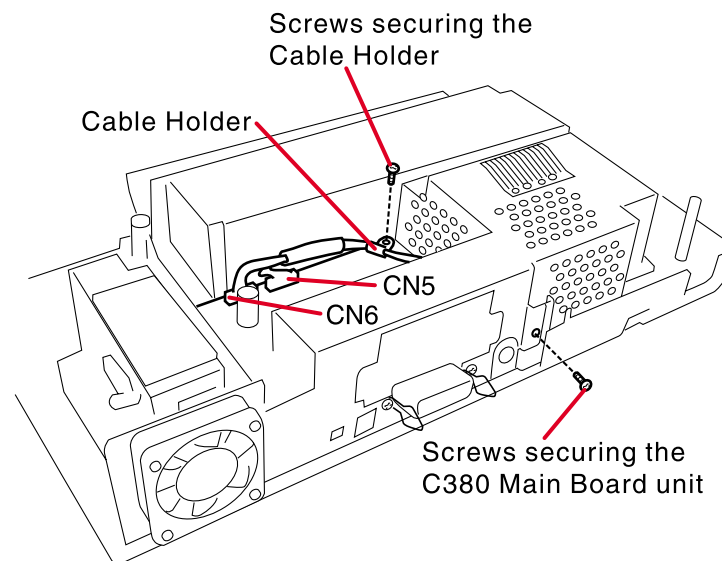

Figure 4-7. C380 Main Board Removal

3. Remove one screw securing the C380 Main board to the bottom frame, and remove the cable holder.

4. Disconnect two connectors CN5 and CN6 from the C380 Main board and remove the C380 Main board unit.



After removing/replacing the C380 Main Board, perform any necessary adjustments. (See Table 4-1)

4.2.4 Relay Board and Cooling Fan Removal

1. Remove the C380 Main board unit. (See Section 4.2.3.)
2. Remove all connectors from the relay board. (See Figure 4-5 when connecting them.)
3. Remove two screws securing the relay board to the shield plate on the C380 Main board, then remove the relay board.
4. Remove three screws securing the cooling fan unit to the shield plate on the C380 main board, then separate the cooling fan from the C380 Main board.
5. Disconnect the connector CN13 (white, 2-pin) from the C380 Main board, and remove the cooling fan unit.

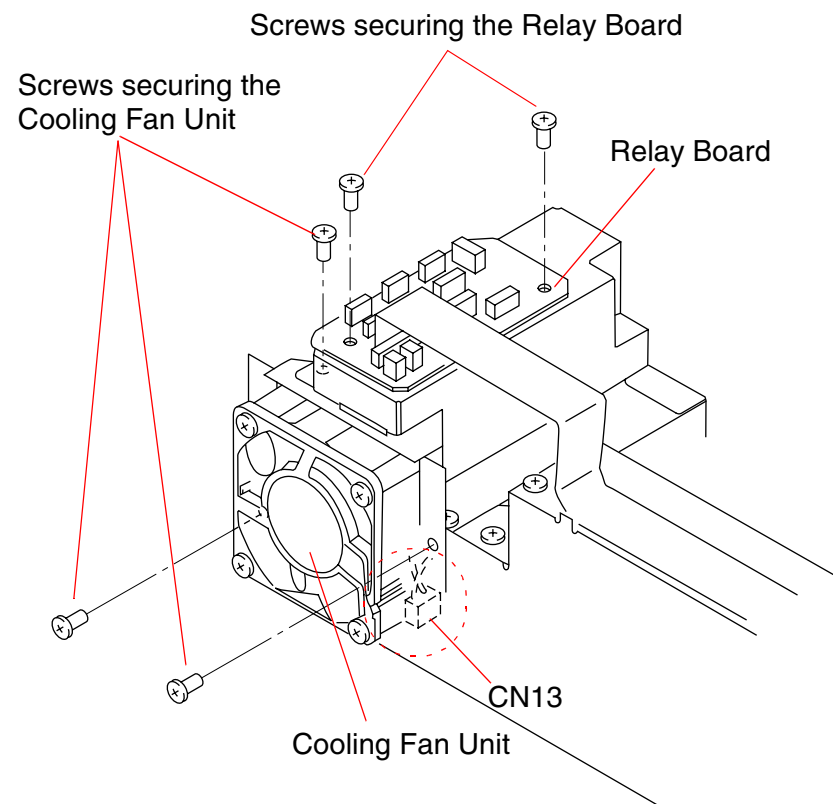

Figure 4-8. Relay Board and Cooling Fan Removal

4.2.5 Shield Plate on the C380 Main Board Removal

1. Remove the C380 Main board unit. (See Section 4.2.3.)
2. Remove the cooling fan unit. (See Section 4.2.4)
3. Remove the remaining four connectors from the relay board. (See Figure 4-5 when connecting them.)
4. Remove two screws securing the right upper main shield plate to the bottom frame and another two screws securing the left upper main shield plate to the bottom frame, then remove the both plates together.

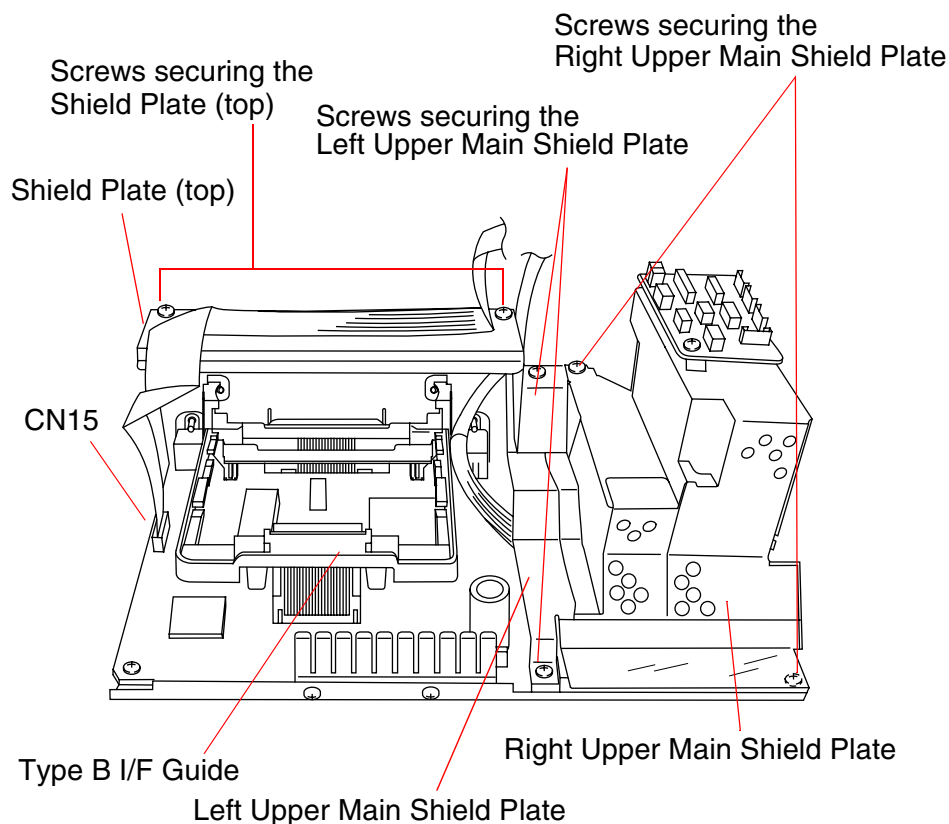

Figure 4-9. Shield Plate Removal (1)

5. Disconnect the FFC from the connector CN15 on the C380 Main board.
6. Remove two screws securing the shield plate (top) to the bottom frame, and remove the shield plate (top).
7. Remove the Type-B interface guide.
8. Remove three screws securing the C380 Main board onto the bottom frame. (Two screws among the three are fixing the reinforcing plate for the Type-B interface guide.)
9. Viewing the C380 Main board from the Centronics I/F connector side, remove three small screws and remove the C380 Main board.

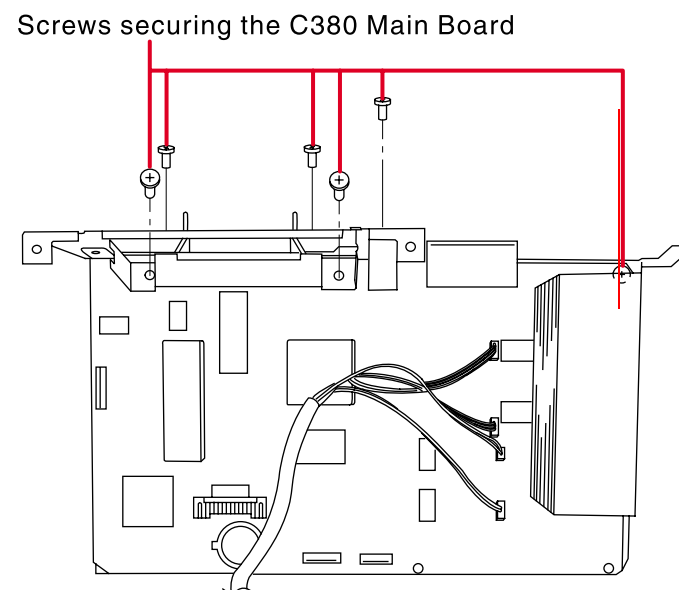

Figure 4-10. Shield Plate Removal (2)

4.2.6 C265 PSB/PSE Board Removal

1. Remove the printer mechanism. (See Section 4.2.2.)
2. Disconnect three connectors CN1, CN2, and CN3 from the C265 PSB/PSE board.
3. Remove four screws (including one for grounding) securing the C265 PSB/PSE board to the lower case and the shield plate on the C380 Main board, then remove the C265 PSB/PSE board unit.

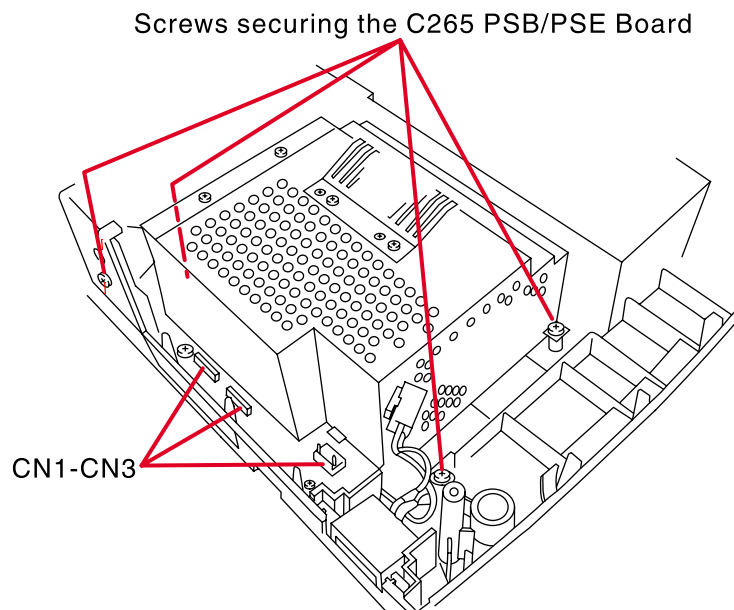

Figure 4-11. Removing the Connectors

4. Remove two screws securing the shield plate on the C265 PSB/PSE board, and remove the shield plate.

Screws securing the Shield Plate

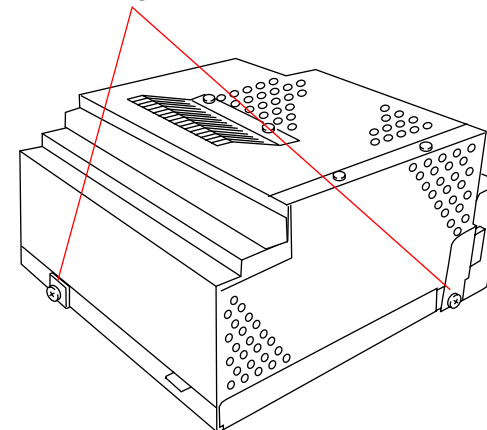

Figure 4-12. Removing the Shield Plate

5. Remove four screws securing the C265 PSB/PSE board to the bottom frame, and remove the C265 PSB/PSE board.

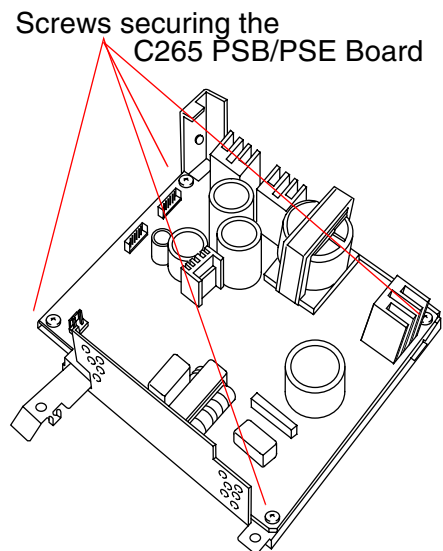

Figure 4-13. C265 PSB/PSE Board Removal

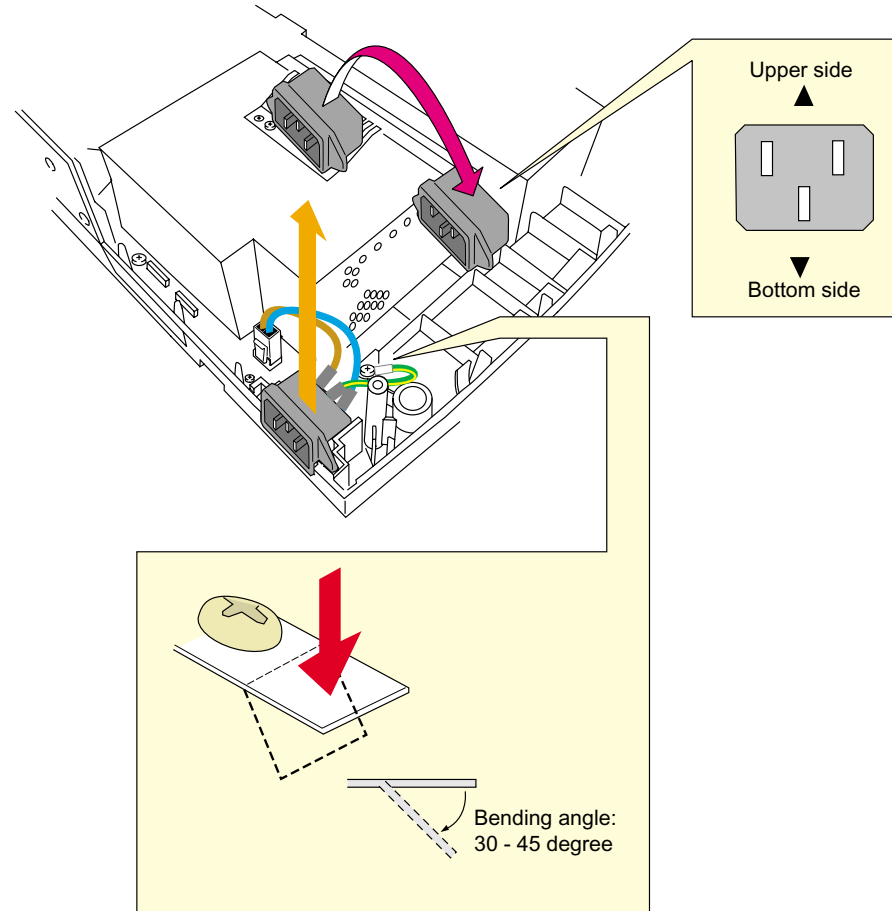

Figure 4-14. AC Inlet installation / Metal plate treatment

CAUTION



Whenever you remove the AC inlet from the lower housing, make sure to do the followings.

- Re-install the AC inlet as shown in figure. (In case if the AC inlet is installed in different direction on the printer which returned for repair, re-install it as instructed here.)
- Push down on a metal plate where a grounding wire is fixed, as to bent it downward for 30 - 45 degree.

4.2.7 Printer Mechanism Disassembly

4.2.7.1 Printhead Removal



- When removing the printhead, make sure the carriage unit is at the left end of the printer mechanism. If you try to remove it from any other position, excess force will be added and the printhead unit may be damaged as a result.
- The printhead for the Stylus Color 900 can not be used for this model.

1. Remove the printer mechanism. (See Section 4.2.2.)
2. If any ink cartridge is installed in the carriage unit, remove it.
3. Release the carriage lock at the back of the printer mechanism, and move the carriage unit to the left end of the printer mechanism.

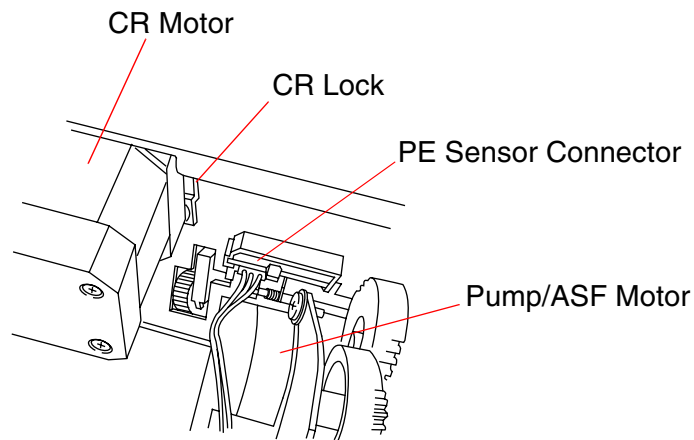

Figure 4-15. Releasing the CR Lock

4. Release two joints (gray) in the cartridge clamps to release the cartridge clamps from the carriage unit.

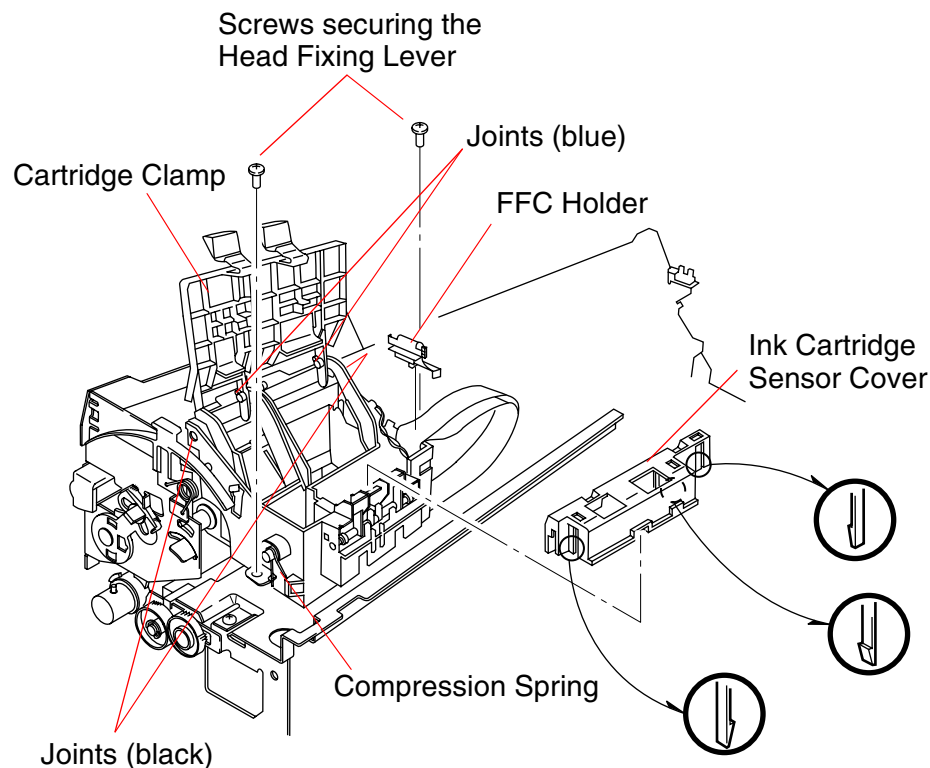

Figure 4-16. Printhead Removal (1)

5. Release two joints (black) in the cartridge clamps from the carriage unit, and remove the cartridge clamps.
6. Remove the compression spring on the left side of the carriage unit.
7. Releasing three hooks securing the cover protecting 2 ink cartridge sensors in the carriage unit, remove the cover.
8. Remove the FFC holder on the right edge of the carriage unit by pulling it upward.

9. Remove two screws securing the head fixing lever which is fixing the printhead by the bottom of the carriage unit, then pull out the suspension plate to the right.
10. Remove two actuators for the ink cartridge sensors. (Note the black one is for the black cartridge and the white one is for the color cartridge.)

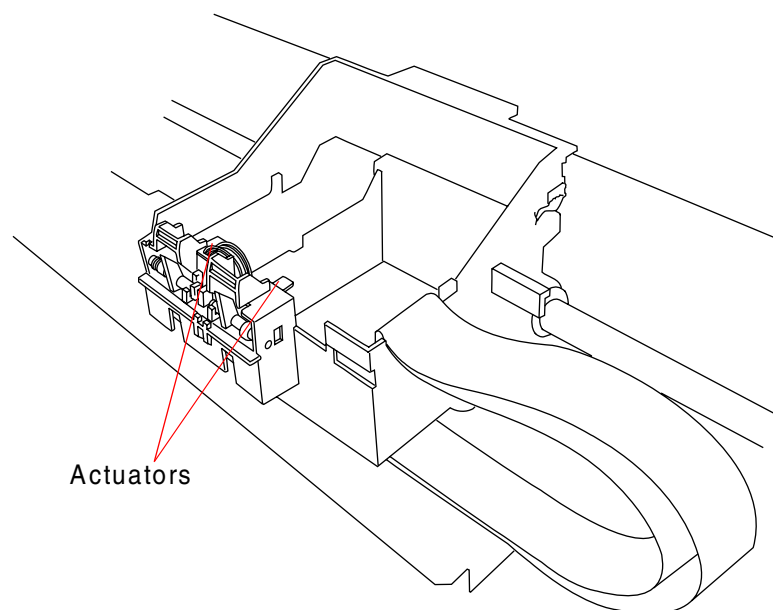

Figure 4-17. Removal of the I/C Detection Actuator

11. Disconnect the green connector for the ink cartridge sensor from the carriage unit.

12. Lifting up the printhead unit, disconnect 2 FFCs and the connector (white, 4-pin) for the ink cartridge sensor.

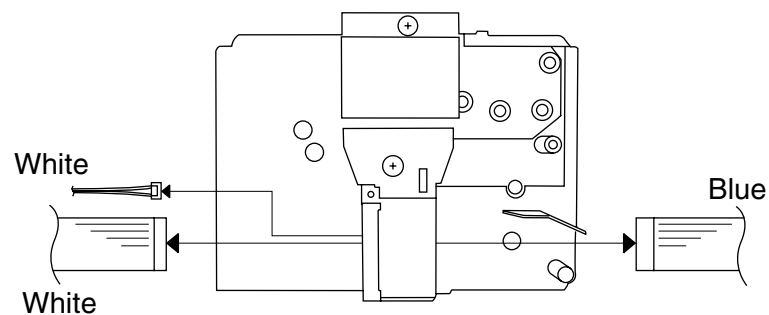

Figure 4-18. Printhead Removal (2)



When installing the printhead FFCs, make sure the reinforcing plates on the FFC are installed correctly as described below:

- White one: on the left side of the printhead.
- Blue one: on the right side of the printhead.



After removing/replacing the printhead, perform any necessary adjustments. (See Table 4-1)

4.2.7.2 CR Motor Removal

1. Remove the printer mechanism. (See Section 4.2.2.)
2. Release the carriage lock at the back of the printer mechanism, then move the carriage unit away from the home position. (See Figure 4-15.)
3. Remove two screws securing the CR motor to the printer mechanism, and remove the CR motor.



After removing/replacing the CR Motor, perform any necessary adjustments. (See Table 4-1)

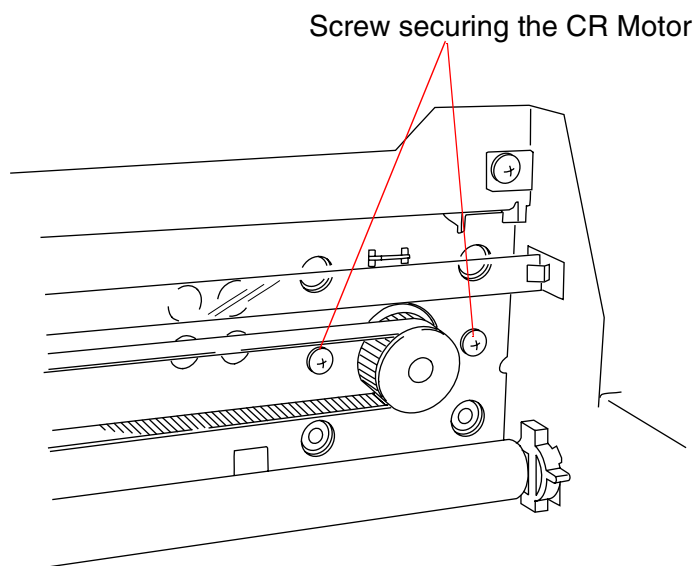

Figure 4-19. CR Motor Removal

4.2.7.3 PF Motor Removal

1. Remove the printer mechanism. (See Section 4.2.2.)
2. Remove the PF roller drive gear from the PF roller shaft.

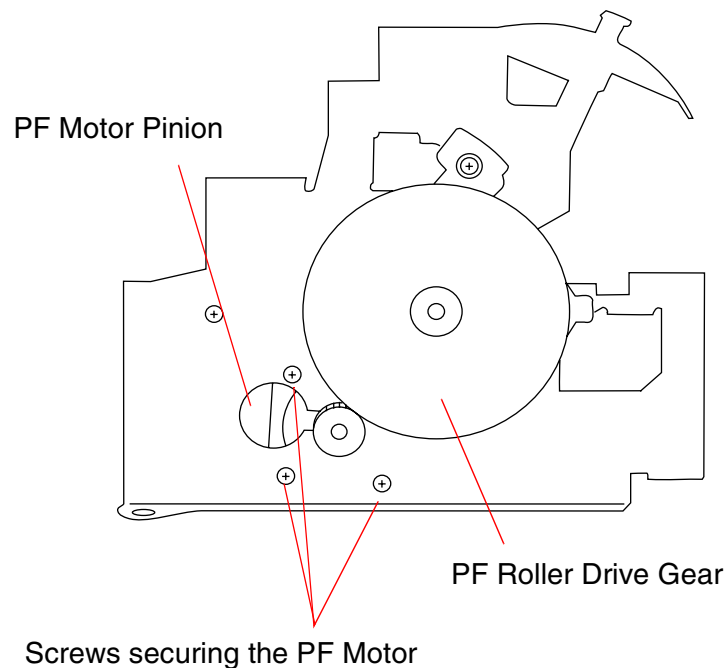

Figure 4-20. PF Motor Removal



- A high-precision gear is used for the PF roller drive gear. Therefore, if the PF roller drive gear has been removed, it must not be used again. Neglecting this may cause a printer malfunction.
- When installing a new PF roller drive gear, be sure to push it intensively by its center area, not forcing a push by its edge.

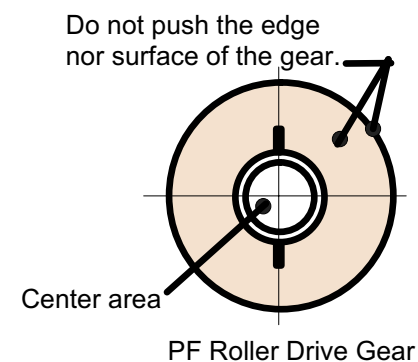

Figure 4-21. PF Roller Driver Gear Installation

3. Remove three screws securing the PF motor to the printer mechanism, and remove the PF motor.



- PF motor pinion gear as well as the PF roller drive roller is a high-precision gear. Therefore, be careful not to damage the gear by hitting it by the frame edges.
- When installing the PF motor, be sure not to touch the pinion gear surface with a screw driver.

4.2.7.4 Pump/ASF Motor and Solenoid Removal

1. Remove the printer mechanism. (See Section 4.2.2.)
2. When removing the solenoid, remove one screw securing the solenoid to the DE subassembly frame, and remove the solenoid. To remove the pump/ASF motor, remove three screws securing the DE subassembly frame to the back of the printer mechanism, then remove the DE subassembly frame along with the pump/ASF motor.
3. Remove two screws securing the pump/ASF motor to the DE subassembly frame, and remove the pump/ASF motor.

Screws securing the DE Subassembly Frame to the Printer Mechanism

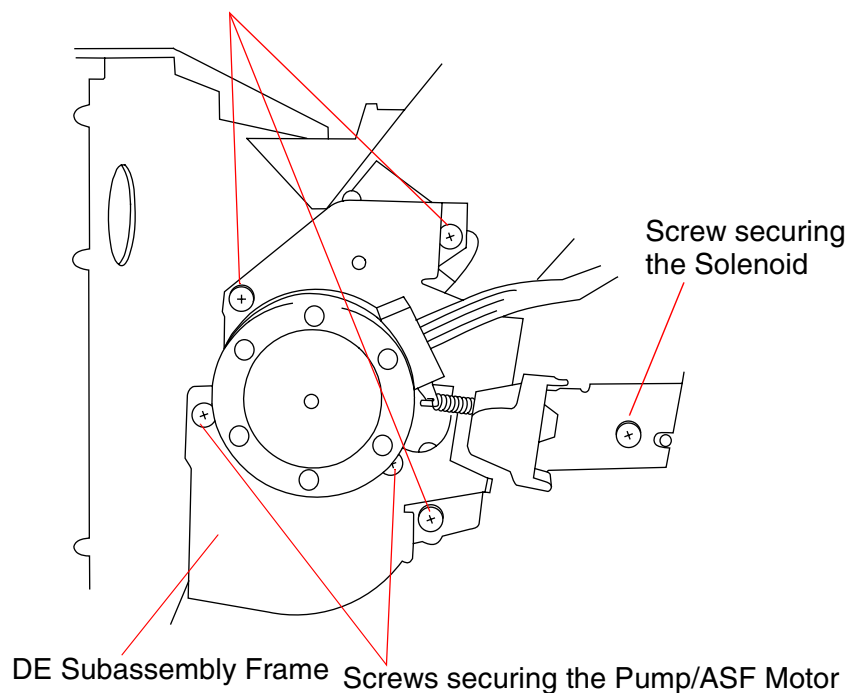

Figure 4-22. Pump/ASF Motor and Solenoid Removal

4.2.7.5 ASF Unit Removal

1. Remove the DE subassembly frame. (See Section 4.2.7.4.)
2. Remove the E-ring fixing the ASF drive shaft and remove the ASF drive gear.
3. Remove three screws securing the ASF unit.
4. Holding the paper hold lever up to the left, remove the ASF unit.

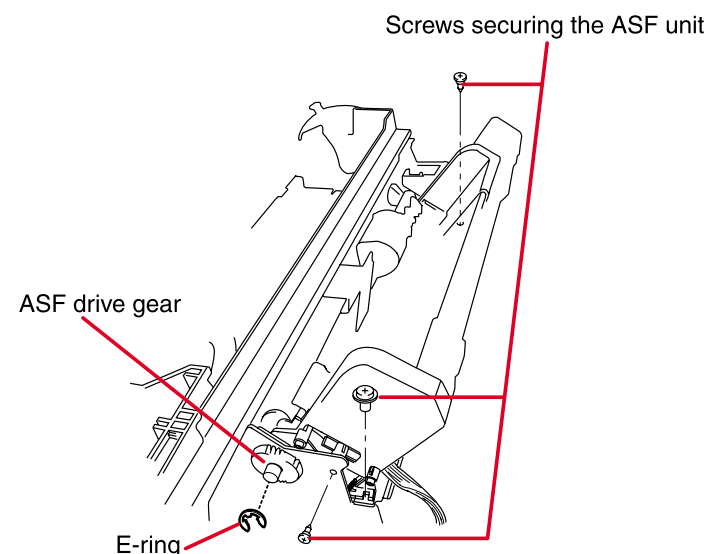

Figure 4-23. ASF Removal



When install the ASF be sure to use the correct type of the screws, as shown below:

- Screw with a flat head: on the right toward the front side of the printer.
- Screw with a washer: on the left toward the front side of the printer.
- Screw with a round head: on the left toward the front side of the printer, screwed horizontally.

4.2.7.5.1 ASF Disassembly

1. Remove the ASF. (See Section 4.2.7.5.)
2. Remove the left shaft E-ring located at the left end of the loading (LD) roller shaft.

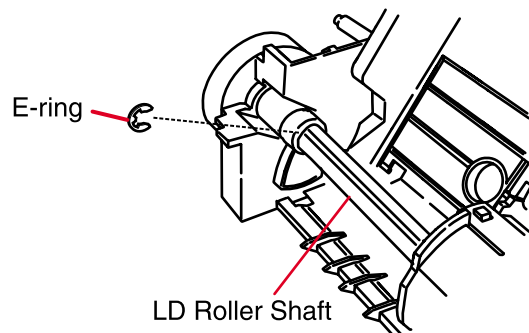

Figure 4-24. Left E-ring Removal

3. Shift the whole LD roller shaft to the left about 2 cm. Then, using tweezers, remove the detection wheel by releasing the tab attaching the detection wheel to the left end of the LD roller shaft.

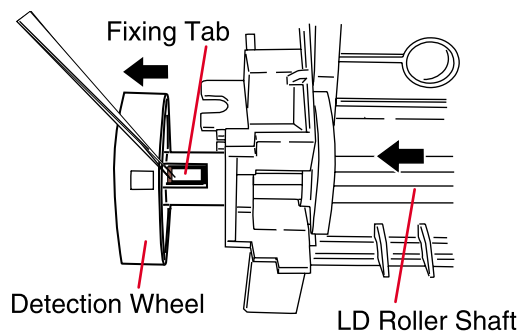

Figure 4-25. Detection Wheel Removal

4. Remove the release hopper lever (right) from the LD roller shaft
5. Remove the right shaft E-ring located at the right end of the loading (LD) roller shaft.

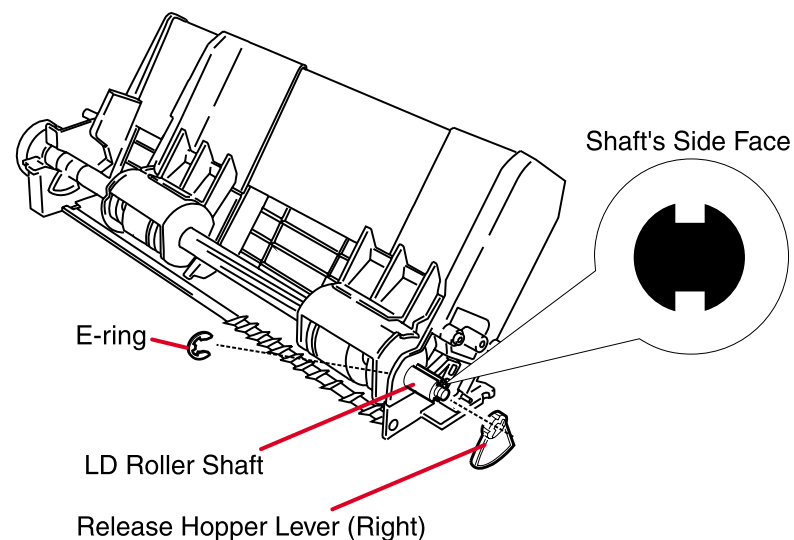

Figure 4-26. Release Hopper Lever Removal

6. Shift the LD roller shaft to the left to pull it out from the paper loading rollers (right and left).



When installing the shaft release hopper lever, pay attention to the direction for installing it. However, the lever does not fit in if the direction is wrong. Therefore, referring to Figure 4-26, find the correct direction with which you can push the release hopper lever without force.

7. Release the peg fixing the hopper assembly to the ASF frame by the top left. Then separate the hopper assembly and the ASF frame.

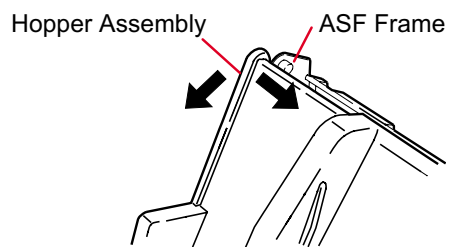

Figure 4-27.

Separating the Hopper Assembly from the ASF Frame

8. Remove the right and left paper loading assemblies from the hopper assembly. (The compression spring is remove together.)
9. Release one hook securing the LD roller cover in the paper loading assembly, and remove the LD roller cover.

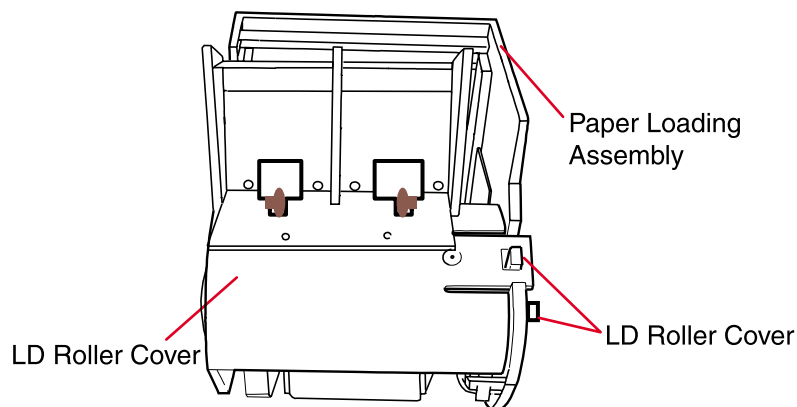

Figure 4-28. LD Roller Cover Removal

10. Release four hooks securing the LD roller assembly to the frame in the paper loading assembly, and remove the LD roller assembly.

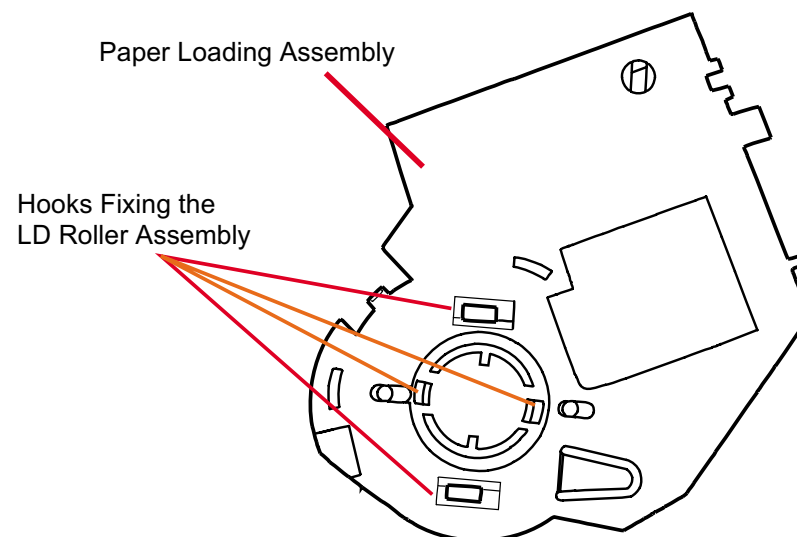

Figure 4-29. LD Roller Assembly Removal



Never touch the rubber part of the LD roller assembly with your bare hands.



- Before assembling the ASF, ensure the following four parts are correctly mounted onto the paper loading assembly.

- One Torsion spring
- One extension spring
- One compression spring
- One rod spring

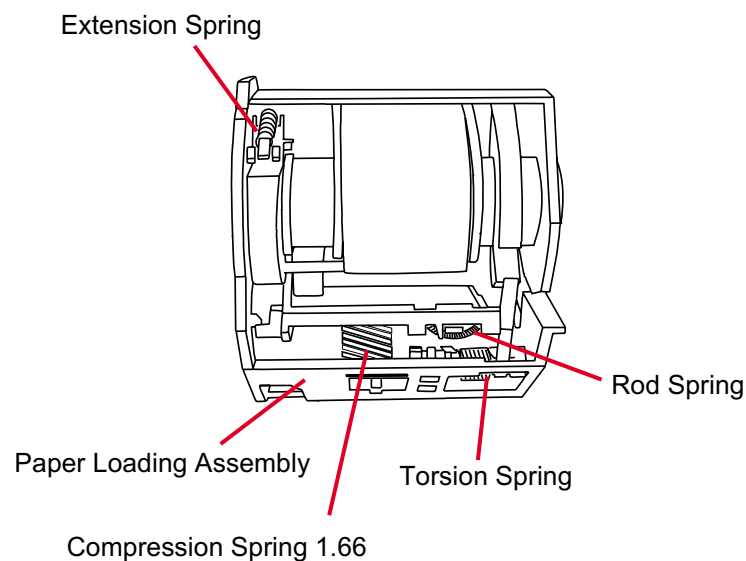

Figure 4-30. Parts in Paper Loading Assembly

- When installing the paper loading assembly, set the edge whose narrow portion is longer than the other to the right.

- When installing the LD roller shaft with the both paper loading assemblies on it into the ASF frame, shift the right paper loading assembly to the right edge of the ASF frame, then fix it by aligning the groove in the back of the paper loading assembly with the rail ribs on the inner side of the ASF frame. Fix the left paper loading assembly also by aligning it with the rail ribs on the inner side of the ASF frame. The left paper loading assembly, however, moves freely from left to right or vice versa.

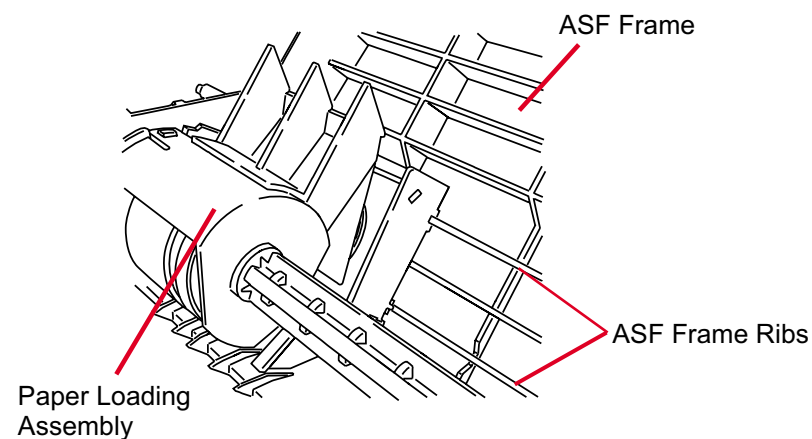

Figure 4-31. LD Roller Shaft Installation



- When installing the hopper assembly into the ASF frame with the paper loading assemblies and LD roller assemblies mounted on it, set the straight end (one of the ends of each spring is bent straight) facing upward. Then hook the straight end to the frame as shown in the top figure below. After setting the assembly, insert tweezers through the cutout in the back of the ASF frame to release the straight end of the compression spring as shown in the bottom figure below.

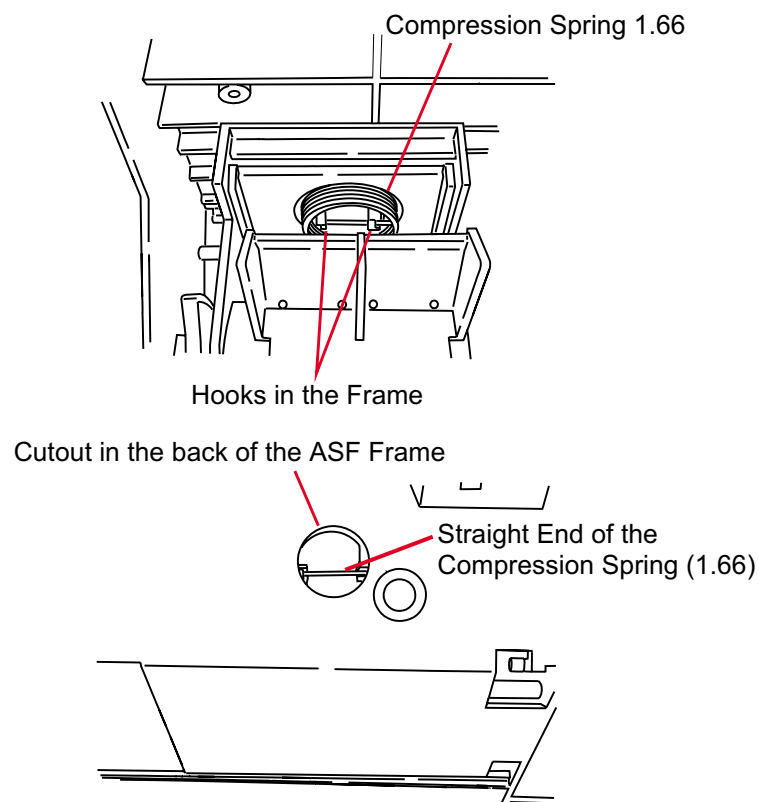

Figure 4-32. Hopper Assembly Installation

- Be sure to fix both right and left pegs on the ASF frame securely into the sockets in the hopper assembly.
- When installing the detection wheel onto the left end of the LD roller shaft, align the protruding portion of the LD roller shaft with the concave portion of the detection wheel.
- Ensure that the left frame of the left paper loading assembly fits correctly into the groove in the left part of the left edge guide in the hopper assembly.
- Make sure the bushing fixing the left hopper release lever by the left part of the shaft is attached to the correct position as shown in the figure below.

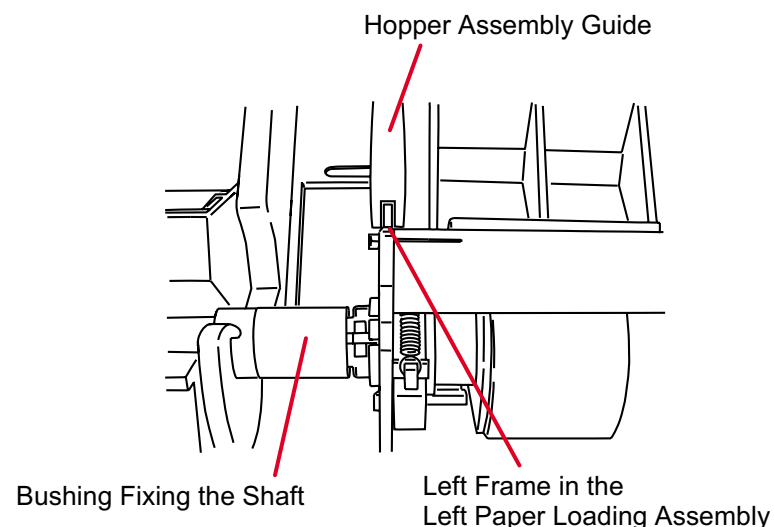

Figure 4-33. Assembling the ASF

4.2.7.6 ASF Sensor Removal

1. Remove the ASF unit. (See Section 4.2.7.5.)
2. Viewing the ASF unit from the front, remove the E-ring (left) fixed at the left end of the shaft.

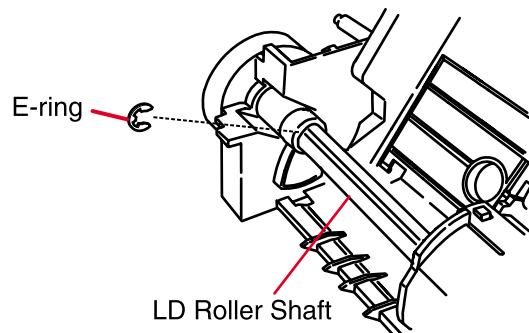

Figure 4-34. Left E-ring Removal

3. Release the hook securing the detection wheel and push the detection wheel to remove.

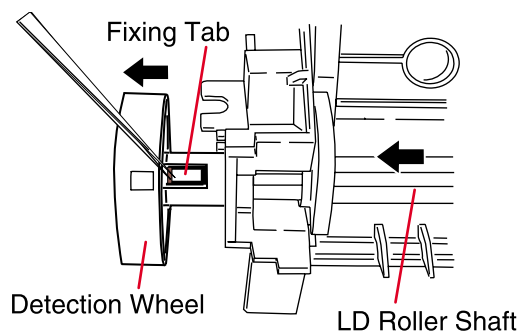

Figure 4-35. Detection Wheel Removal

4. Disconnect the connector from the ASF sensor.
5. Using tweezers, release two of the hooks securing the ASF sensor, and remove the ASF sensor.

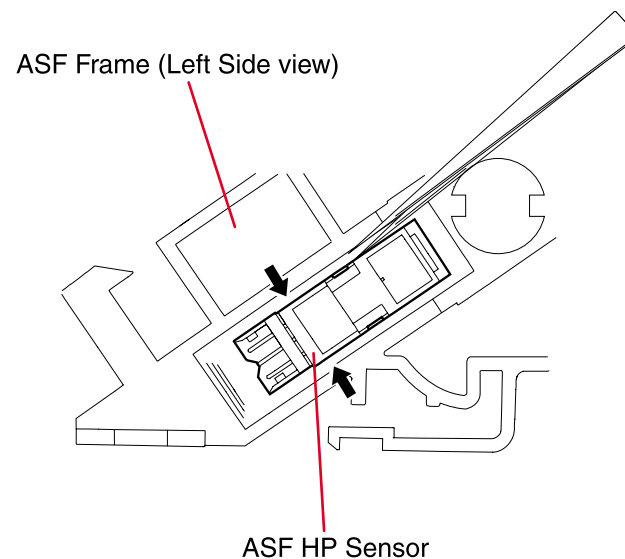

Figure 4-36. ASF Sensor Removal

4.2.7.7 CRHP Sensor Removal

1. Remove the printer mechanism. (See Section 4.2.2.)
2. Pushing two of the four hooks securing the CRHP sensor, remove the CRHP sensor.

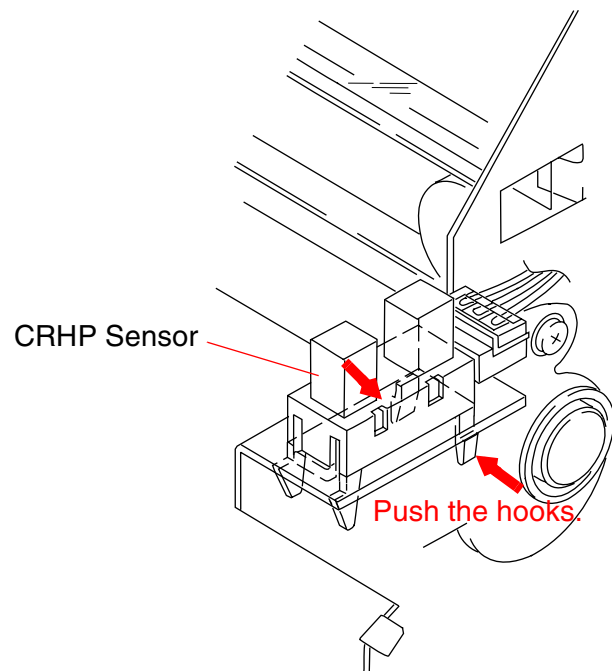

Figure 4-37. CRHP Sensor Removal

4.2.7.8 PE Sensor Removal

1. Remove the printer mechanism. (See Section 4.2.2.)
2. Release the hook securing the PE sensor at the back of the printer mechanism, and remove the PE sensor.

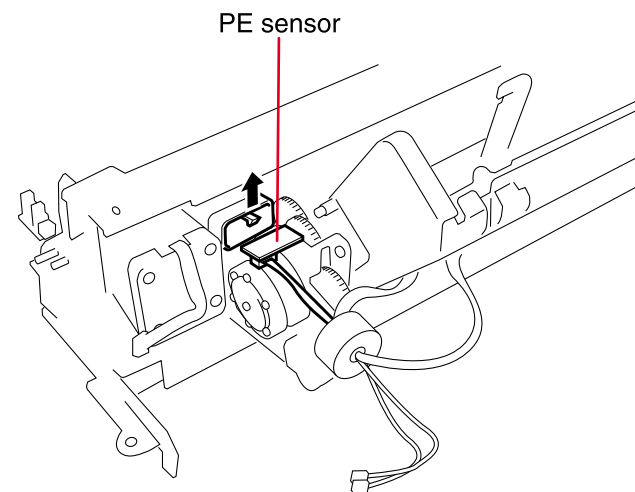

Figure 4-38. PE Sensor Removal

4.2.7.9 Encoder Belt Sensor Removal

1. Remove the printer mechanism. (See Section 4.2.2.)
2. Using your hand, push the fixing lever holding the encoder belt by the left end to the right, then remove the encoder belt when the encoder belt is released enough.

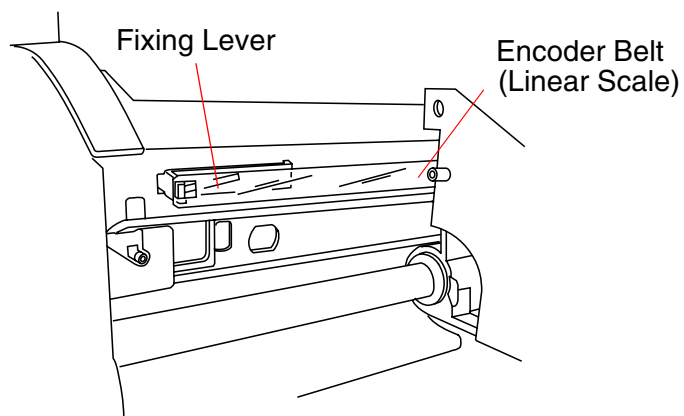

Figure 4-39. Encoder Belt Removal



When installing the encoder belt, be sure to place it between the flags for the photo sensor attached to the back of the carriage unit. Failure to do so will bring a fatal error at power on.

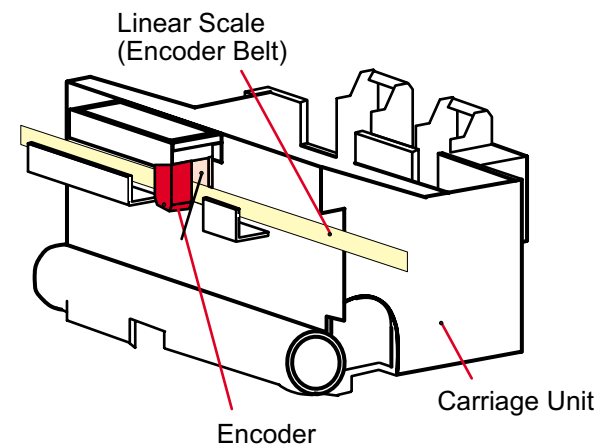

Figure 4-40. Positioning the Encoder Belt

4.2.7.10 Carriage Unit Removal

1. Remove the printer mechanism. (See Section 4.2.2.)
2. Remove the encoder belt. (See Section 4.2.7.9.)
3. Remove the tension spring from the belt pulley holder.

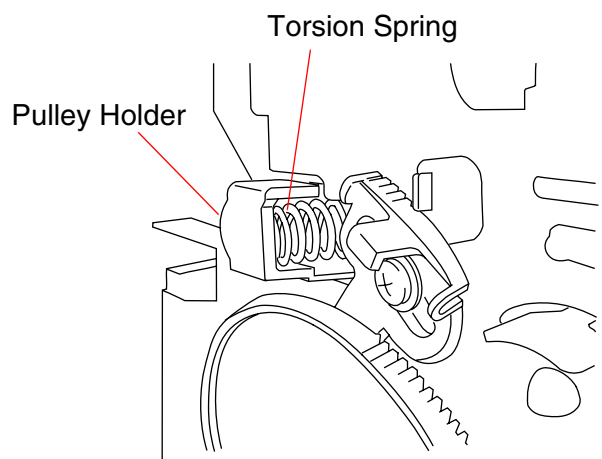

Figure 4-41. Belt Tension Spring Removal

4. Push the belt pulley holder to the right (HP side) to fit the holder in the cutout in the left frame, then push out the belt pulley holder to the front.
5. Remove the spring fixing the paper thickness adjusting lever with tension.

6. Release the hook securing the paper thickness adjusting lever to the printer mechanism, then push the paper thickness adjusting lever inward to remove it.

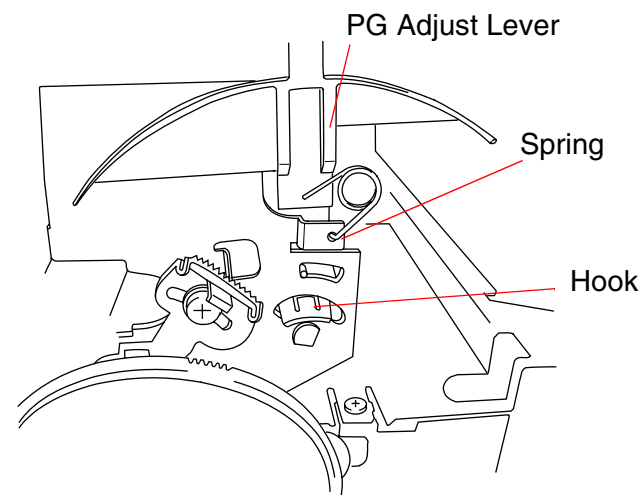

Figure 4-42. PG Adjust Lever Removal

7. Remove the E-ring fixing the carriage guide shaft and the parallelism adjustment bushing (right) and then the washer and the spring washer to release the parallelism adjustment bushing (right). (Note the concave side of the spring washer faces to the printer mechanism side.)
8. Remove the screw fixing the parallelism adjustment bushing (right).

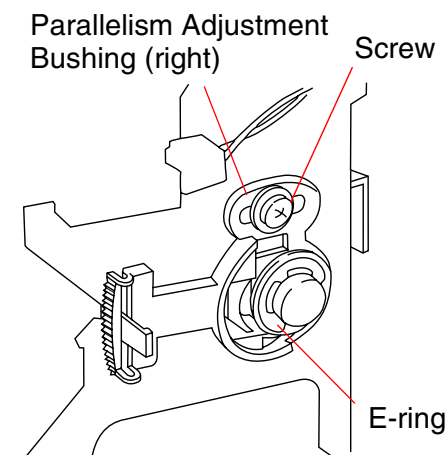

Figure 4-43. Parallelism Adjustment Bushing Removal

9. Turn the parallelism adjustment bushing to the left to align the bushing with the cutout in the left frame, then pull the parallelism adjustment forward.
10. Shift the whole carriage guide shaft to the right to release the joint at the left end, then remove the carriage guide shaft and carriage unit together.



- After removing/replacing the Carriage Unit (Carriage Guide Shaft), perform any necessary adjustments. (See Table 4-1)
- When removing the carriage guide shaft, pay attention to the oil pad as it will come off the carriage.
- When lubricating the carriage guide shaft, be sure to follow the correct order by referring to Chapter 6.

4.2.7.11 Pump Unit Removal

1. Remove the printer mechanism. (See Section 4.2.2.)
2. Remove three screws securing the pump unit and remove the pump unit along with the frame.

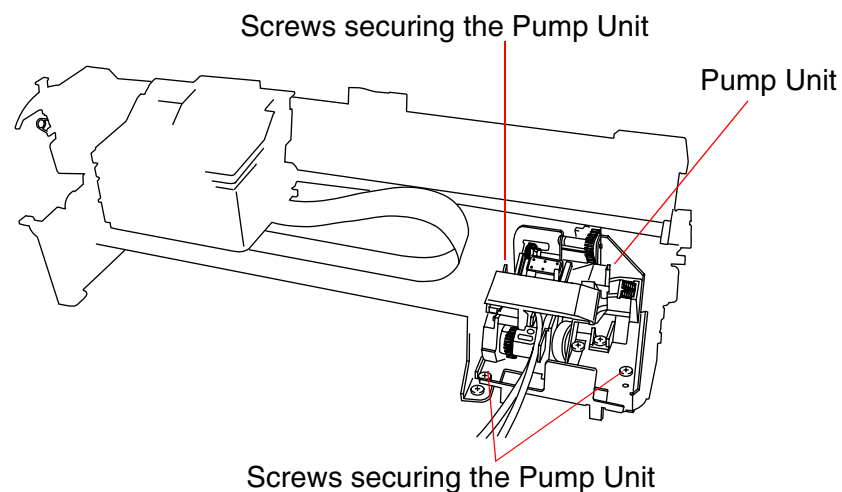

Figure 4-44. Pump Unit Removal

4.2.7.12 Paper Eject Frame Removal

1. Remove the printer mechanism. (See Section 4.2.2.)
2. Remove the pump unit. (See Section 4.2.7.11.)
3. Remove the carriage unit. (See Section 4.2.7.10.)
4. Remove hooks securing 2 FFC holders (one on the paper eject frame and the other on the right frame), and remove the FFC holders.

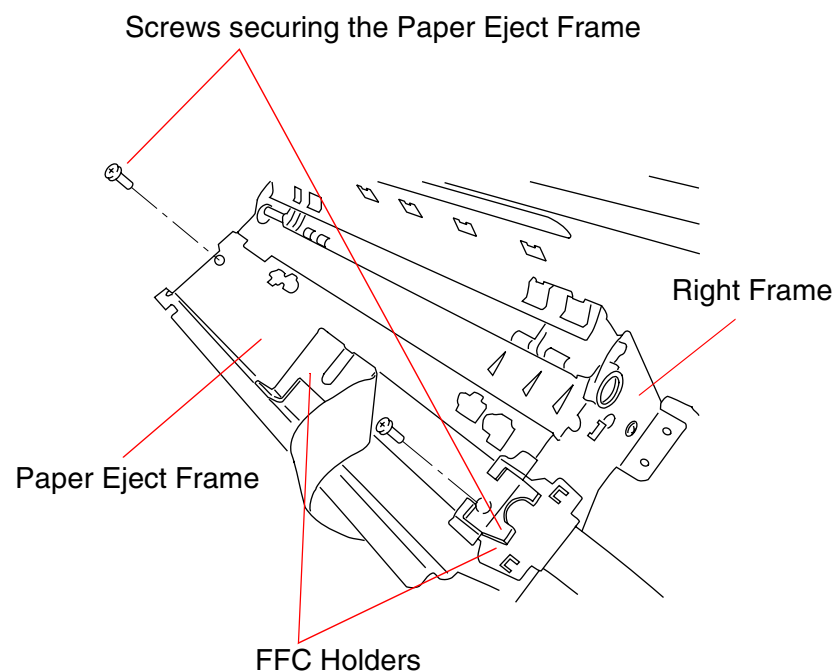

Figure 4-45. Paper Eject Frame Removal

5. Remove two screws securing the paper eject frame, and remove the paper eject frame.

4.2.7.13 Paper Eject Roller Removal

1. Remove the paper eject frame. (See Section 4.2.7.12.)
2. Turning the bushings fixing the paper roller by the both ends upwards, and remove the paper eject roller.

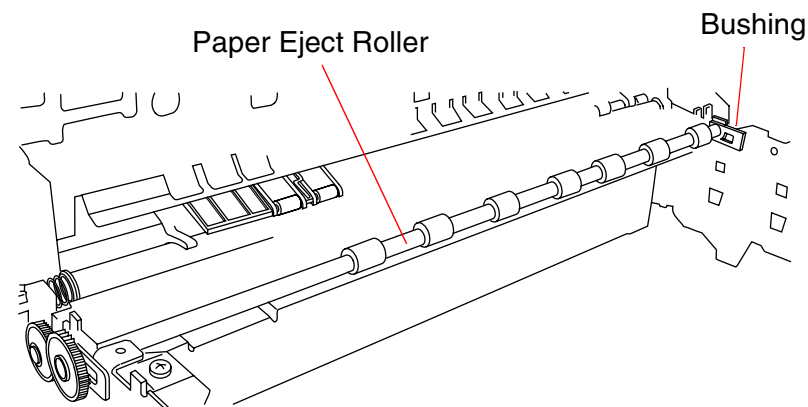

Figure 4-46. Paper Eject Roller Removal

4.2.7.14 Platen Removal

1. Remove the paper eject roller. (See Section 4.2.7.13.)
2. Lift up the front edge of the platen, and remove the plate.

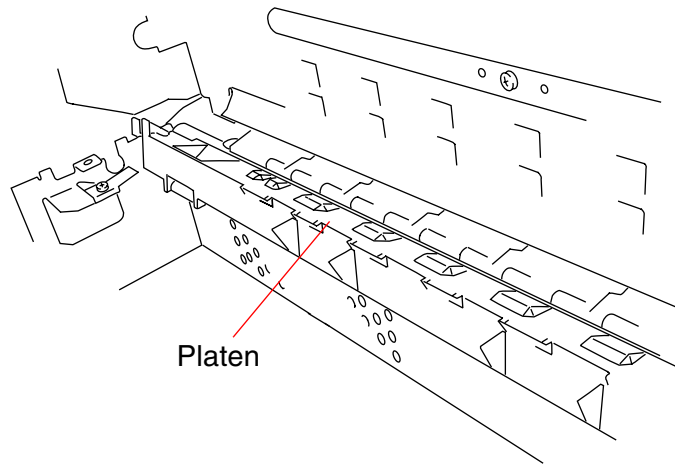

Figure 4-47. Platen Removal

4.2.7.15 PF Roller Removal

1. Remove the platen. (See Section 4.2.7.14.)
2. Remove the screw securing the paper support lever to the printer mechanism, and remove the paper hold lever along with the stay.

Screw Securing the Paper Support Lever

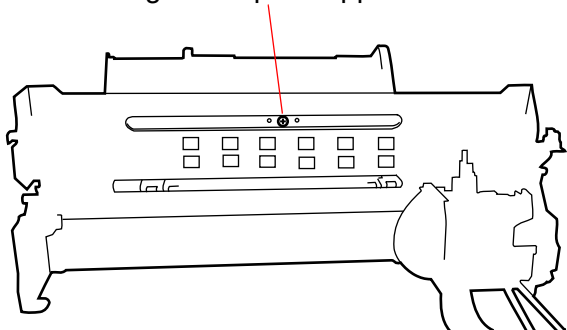

Figure 4-48. Paper Hold Lever Removal

3. From the back of the printer mechanism, release the torsion springs securing the paper guides (upper) to release the paper guides (upper).

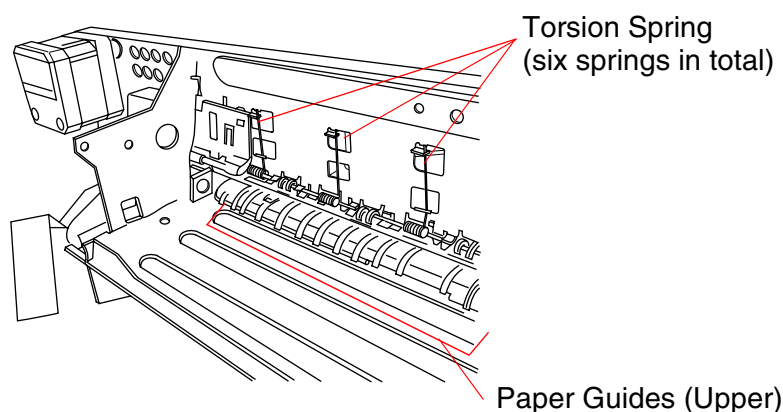

Figure 4-49. Releasing the Paper Guide (Upper)

4. Pull all the paper guides (upper) out to the front side of the printer mechanism (paper ejection side).



When installing the paper guide located on the left edge (HP side), be sure to insert it from the rear side of the printer mechanism: because it has a cutout in which the actuator for the PE sensor falls, and if the paper guide is removed to the rear, the actuator will be damaged.

5. Remove the tension spring stretching the encoder belt from the back of the printer mechanism.

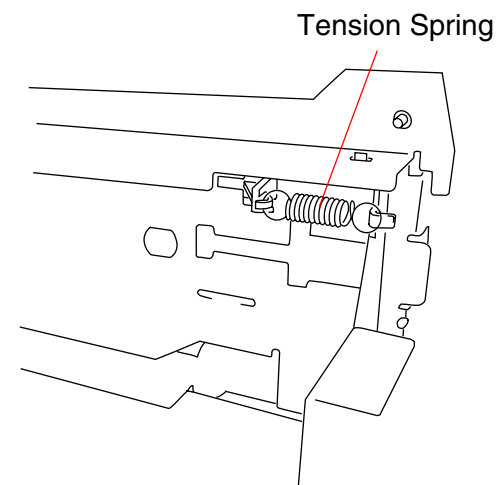

Figure 4-50. Tension Spring Removal

6. Remove two screws securing the top frame and remove the top frame.

- Remove three screws securing the top frame (two by the front and the rest by the rear right of the printer mechanism), and remove the top frame.

Screws securing the Top Frame

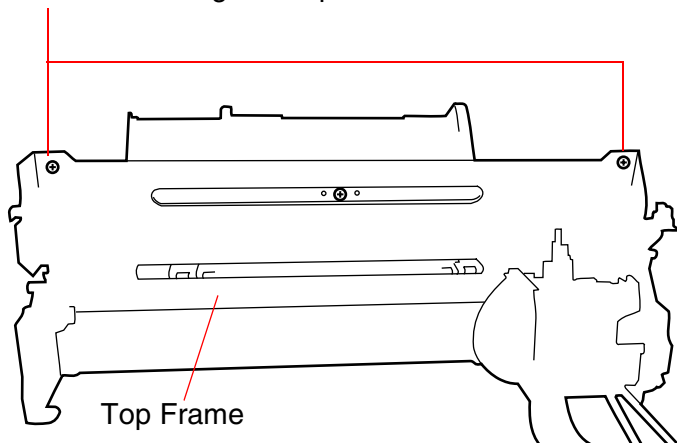
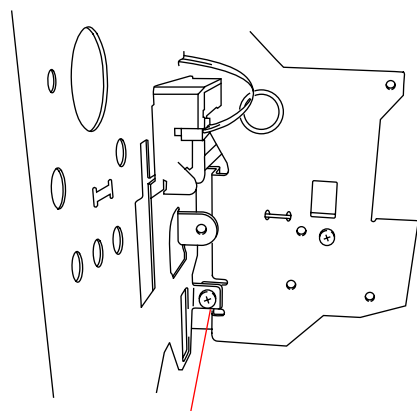

Figure 4-51. Top Frame Removal (1)



Screw securing the Top Frame (at the back)

Figure 4-52. Top Frame Removal (2)

- among two bushings securing the PF roller by the both ends, turn the left one (on the 80th column side) upward to release the PF roller, then shift the whole shaft to the right and remove the PF roller. (The paper guide (lower) is remove together.)



Never touch the PF roller with your bare hands.

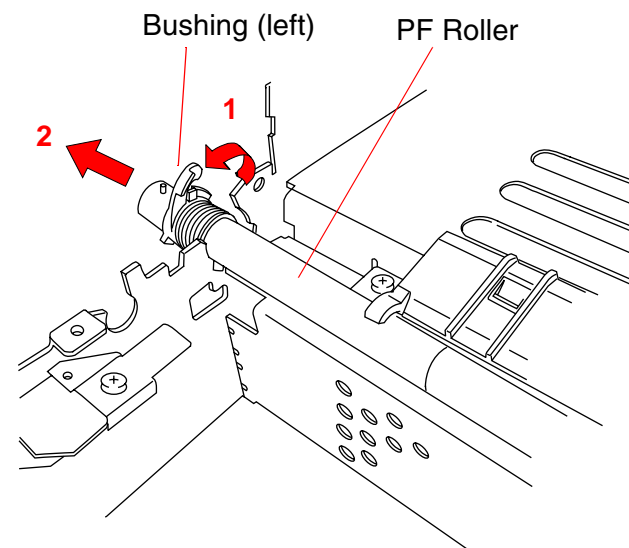

Figure 4-53. PF Roller Removal

CHAPTER

5

ADJUSTMENT

5.1 Overview

This chapter contains all adjustments procedures for Stylus Color 980.

5.1.1 Conditions for Each Adjustment

This section includes each adjustment which is required after repairing or replacing specific parts used in the Stylus Color 980. Some of the adjustments have the specified order to perform, depending on the contents of the adjustment. Therefore, observe the points shown under the heading "CAUTION" in the right column well and perform the adjustments properly in the correct order, referring to Table 5-1 - Table 5-3.



- When adjusting the printer, be sure to refer to Table 5-1 to check for all the necessary adjustment items and perform them in the correct order. Failure to do so may directly affect to print quality adversely.
- In this printer, the head angle adjustment can be done without removing the upper case. However, since the head fixing plated is installed with two screws, observe the instruction in this manual to perform the adjustment properly.
- The C language used in the service program only applies to the PCs which run DOS/V. Therefore, be sure to run DOS/V to use the service program, since If other types of PCs such as 98-series or the one which does not support bidirectional communication system are used, the program does not run properly and adjustments can not be made.
- When performing Initial Ink Charge forcibly, be sure to have a new ink cartridge ready.
- Before clearing the waste ink pad counters using the service program, make sure the waste ink pads have been replaced in advance. Lack of this operation may cause the ink to leak from the lower case.

Table 5-1.
Actions Taken and Corresponding Adjustments in Order

No.	Actions taken	Step	Corresponding adjustment required
1	Printhead replacement	1	Install a new I/C in the I/C replacement sequence (user performable) and make sure it is completed. <Purposes> 1. To avoid counter mis-matching 2. To preliminarily avoid head hot error which would occur in Step 3. (For details, refer to Chapter 2 / Sensor descriptions.)
		2	Perform "Ink Charge Flag Reset" using the service program and then turn the printer off. In 10 seconds, turn the printer back on, and the "Initial Ink Charge" begins automatically.
		3	Input a 22-digit ID in "Head Actuator Voltage ID Input" using the service program.
		4	Perform "Head Angular Adjustment" using the service program.
		5	Perform "Bi-Directional Adjustment" using the service program.
2	C380 Main board replacement	1	Input the model name in the service program.
		2	Select the destination in the service program. <Purpose> To set the CG and default value.
		3	Input a 22-digit ID in "Head Actuator Voltage ID Input" using the service program.
		4	Perform "Bi-Directional Adjustment" using the service program.

Table 5-2. (continued)
Actions Taken and Corresponding Adjustments in Order

No.	Actions taken	Step	Corresponding adjustment required
3	CR shaft replacement or cleaning	1	Referring to Chapter 6 "Maintenance", remove the oil pad from the carriage.
		2	Referring to Chapter 6 "Maintenance", perform the followings: 1. Clean the carriage shaft surface. 2. Perform the preliminary lubrication. 3. Oil the newly installed pad. 4. Install the carriage shaft to the carriage unit. NOTE: Make sure the printhead has been removed before supplying oil to the new oil pad.
		3	Reinstall the printhead to the carriage.
		4	Perform Parallelism adjustment.
		5	Enter the I/C replacement sequence to install a new I/C and make sure it is completed. <Purposes> 1. To avoid counter mismatching. 2. To preliminarily avoid head hot error which would occur in Step 7. (For details, refer to Chapter 2 / Cooling Fan Driver Circuit.)
		6	Perform "Ink Charge Flag Reset" using the service program and then turn the printer off. In 10 seconds, turn the printer back on, and the "Initial Ink Charge" begins automatically.
		7	Perform "Head Angular Adjustment" using the service program.
		8	Perform "Bi-Directional Adjustment" using the service program.

Table 5-3. (continued)
Actions Taken and Corresponding Adjustments in Order

No.	Actions taken	Step	Corresponding adjustment required
4	Clogged nozzles recovery	1	Perform "Head Cleaning" using the service program.
		2	If the step 1 is not effective, perform "Ink Charge Flag Reset" using the service program and then turn the printer off. In 10 seconds, turn the printer back on, and "Initial Ink Charge" begins automatically.
5	Waste Pad replacement	1	Replace the waste ink pad.
		2	Return the current counter values for the waste ink pads to zero by selecting "Indication of the counter value of waste ink pad" then "Clear the protection counter value" using the service program.
6	CR motor replacement	1	Perform "Bi-Directional Adjustment" using the service program
7	Program ROM replacement*1	1	Input a 21-digit ID in "Head Actuator Voltage ID Input" using the service program
		2	Perform "Bi-Directional Adjustment" using the service program.

*1: When the ROM (revision TEE01A, 01B, or 01C) is replaced with the revised one (TEE10D or newer).

NOTE:

Installing a ROM (version TEE01D or newer) in place of the older version (version TEE01A, 01B 01C) will change the output waveform control for ink firing. For this reason, you are required to re-input the head ID and perform Bi-D adjustment whenever you have replaced the ROM (version TEE01A, 01B, or 01C) with the revised one (revision TEE01D, or newer)

5.2 Adjustments

This section describes the procedure for each adjustment. Be sure to observe the CAUTION and tables in Section 5.1.1 before starting adjustments.

5.2.1 Preliminary Operation

Perform the preliminary operation, which is required prior to actual adjustment operation, by following the steps below.

1. Connect the PC and printer with PRIF4.
2. Turn the printer on.
3. Launch the service program (SC980.EXE) attached to the service manual for the Stylus Color 980.
4. The following screen appears.



Figure 5-1. Screen after Start-up Sequence

5. Select the name of the model you have connected.

NOTE:

- If we OEM this product in future, there will be a possibility that more model names are added to the option. In this case, be sure to select the model name you are dealing with correctly.
- The command required to write adjustment value for each adjustment includes a model-unique parameter, which is called R-code. The purpose of selecting the model name is to define the parameter which is specific to the model.

6. Select the printer port you use.
7. Select the destination which applies to the model on which you are making adjustments.
8. Select "Individual Adjustment Service Program".
9. The following screen appears.



Figure 5-2. Preliminary Operation Screen

10. Click "OK".
11. The main adjustment screen shown in Figure 5-3. appears.

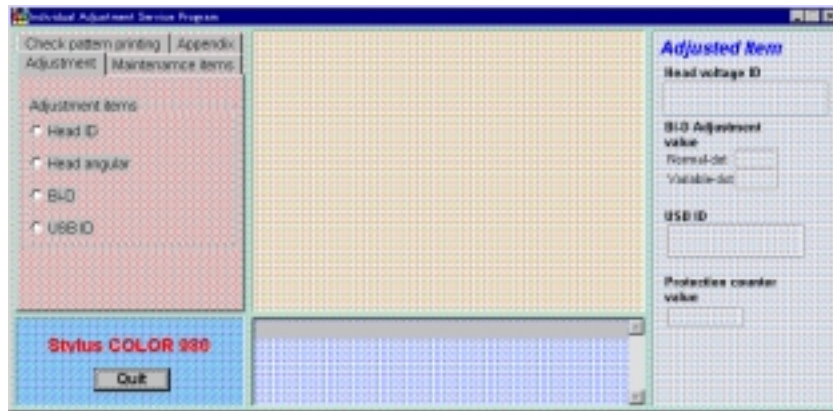

Figure 5-3. Main Adjustment Menu Screen

5.2.2 Head Actuator Voltage Input

This section describes how to input Head ID. Perform this operation under the following conditions:

1. The printhead has been replaced.
2. The C380 Main board has been replaced.

NOTE:

- After replacing the printhead, be sure to install a new ink cartridge in the I/C replacement sequence before inputting the Head ID.
- After replacing the printhead, if you install the I/C before turning on the printer, the next power on may cause the Head Hot Error (Panel Indication = Ink Out Error), and the printer loses all controls by the PC in that error condition.

1. Before replacing the printhead or main board, make a note of a 22-digit head ID.
2. Referring to Section 5.2.1, perform the preliminary operation.
3. Select "Head ID".
4. The following screen appears.

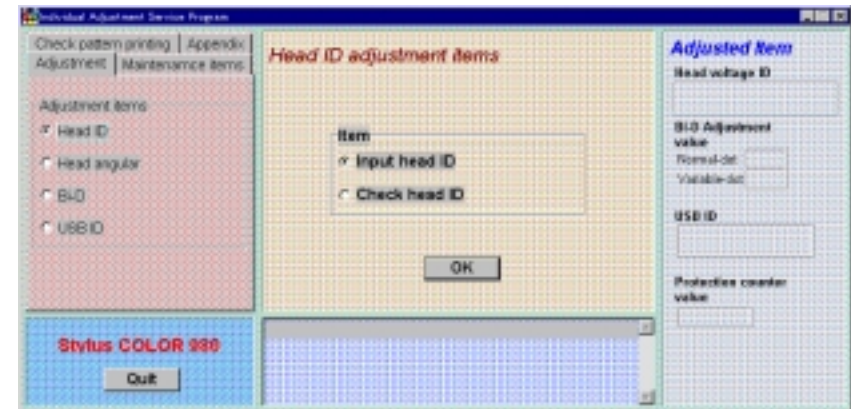

Figure 5-4. Head ID Input / Check Selection Screen

5. Select "Input head ID".
6. Click "OK".



Figure 5-5. Head ID Input Screen

7. Type exactly the 22-digit Head ID you made a note of. (First digit is hidden when you type 22nd digit.)

8. Click "OK".
9. When the program submit the ID you type, following screen appears.



Figure 5-6. Head ID Input Screen

10. Though the head ID inscribed on the printhead when you proceed head ID retrieval, select the "Previous" and refer the next section (5.2.3).

5.2.3 Head ID Retrieval

The section describes the procedure for head ID retrieval. This operation enables you to confirmation the head ID without defecting ink cartridge.

NOTE:

Though the sticker on the printhead indicates 22-digit of head ID, this function shows only 21-digit. The 22nd digit is the printhead management sign and there is no relation to EEPROM. So it is not regarded in case of retrieval and input.

1. Perform the operation of Head Actuator Voltage Input (5.2.2) 1-3.
2. Select "Check head ID".
3. Click "OK".
4. The following screen appears.

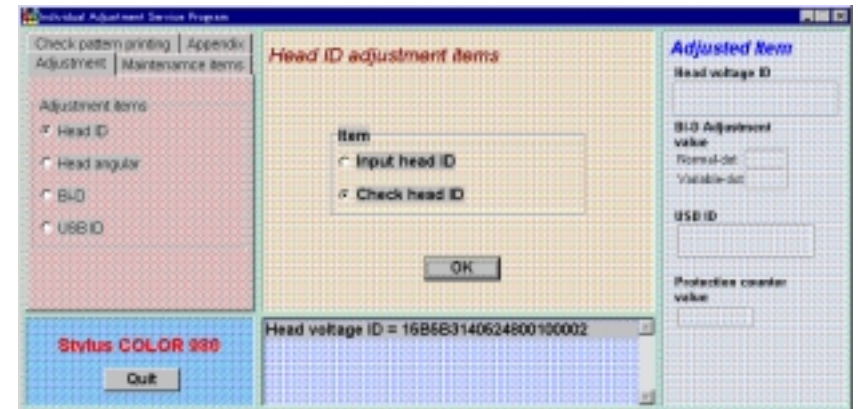

Figure 5-7. Check head ID screen

5.2.4 Head Angular Adjustment

TBD

5.2.5 Bi-Directional Adjustment

This section describes how to make Bi-Directional Adjustment. This adjustment must be made under the following conditions.

1. The printhead has been replaced/removed.
 2. Vertical lines are not aligned. (A print problem has occurred.)
 3. C380 Main Board has been replaced.
4. When the ROM (version TEE012A, 01B, or 01C) is replaced with the revised one (TEE01D or newer). (See Section 5.2.2 for details).

NOTE:

Bi-Directional Adjustment value is not cleared with EEPROM Initialization (resetting the protection counter and specific addresses).

1. Referring to Section 5.2.1, perform the preliminary operation.
2. Select "Adjustment" from the main adjustment menu (Figure 5-3) then "Bi-D".
3. The following screen appears.

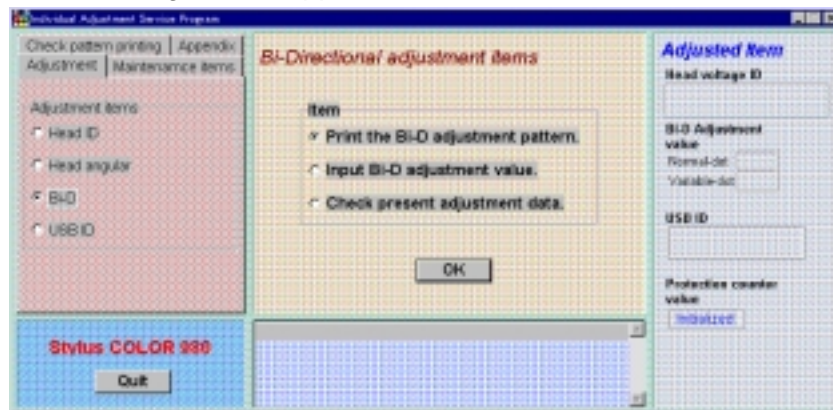

Figure 5-8. Bi-Directional Adjustment Screen

4. Select "Print the Bi-D adjustment pattern" in the screen.
5. Click "OK".
6. The following screen appears.

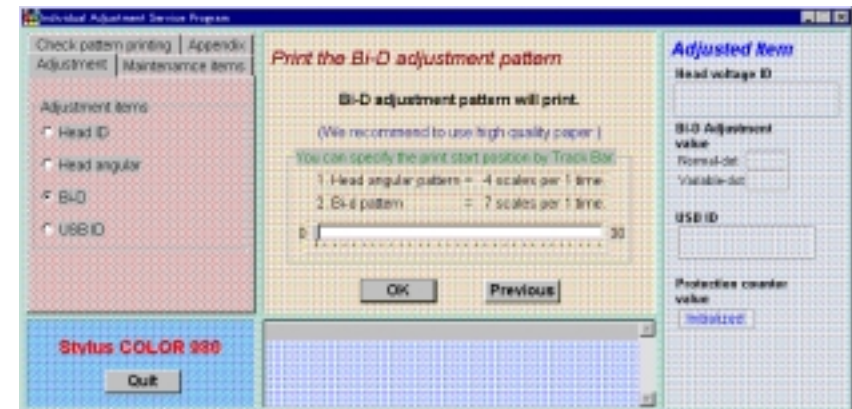

Figure 5-9.
Screen after "Print the Bi-D adjustment pattern" is Selected

7. Click "OK".
8. The following screen appears and the printer runs the Bi-D adjustment pattern consequently.

13. The following screen appears.

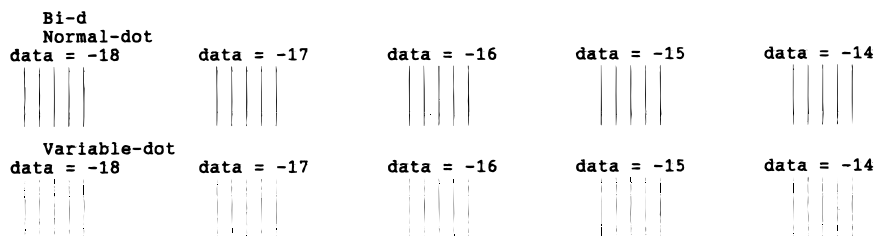

Figure 5-10. Bi-D Adjustment Pattern Sample

9. The sample pattern is printed as shown Figure 5-10. Select the value the most closely aligned vertical line. (In case of Figure 5-10, data No.-16 is most closely aligned at normal dot)
10. Click “Previous” to return to the Bi-Directional Adjustment Screen (Figure 5-8).
11. Select “Input Bi-D adjustment value”.
12. Click “OK”.

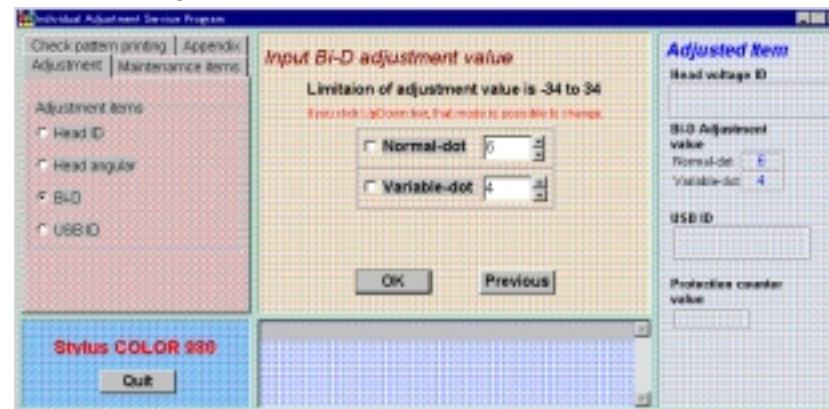

Figure 5-11. Bi-D Adjustment Mode Screen

14. Set the normal dot and vertical dot values according to the value on step 9. (In case of Figure 5-10, Set to the value to -16 at normal dot.)

NOTE:

Regardless of the value you have input, the center value (selected value) in the next Bi-D pattern sample will be “0”. The value in the range from -34 to 34 can be input.

15. When the desirable value is selected, click “OK”. The following screen appears.

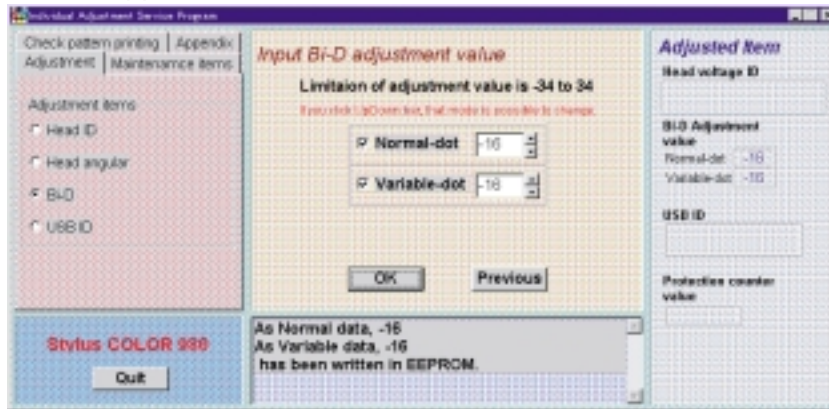

Figure 5-12. Screen after the Adjustment Value has been Written

16. Click “Previous” to return to the Bi-D Adjustment screen” (Figure 5-8).
17. To execute the adjustments, press the ESC key 2 times. The printer turns off and back on in an instant and the adjustment values are stored in the EEPROM. If you need to check the adjustment results, perform the A4 normal paper printing.

NOTE:

Bi-Directional Adjustment is the last adjustment to be made on the program. Never perform adjustments such as “Head Angular Adjustment” and “Head Actuator Voltage ID Input” after “Bi-Directional Adjustment”. (Refer to Table 5-1 for details.)

5.2.6 USB ID Input

This section describes the procedure of USB ID input.

1. Referring to Section 5.2.1, perform the preliminary operation.
2. Select "USB ID".
3. The following screen appears.

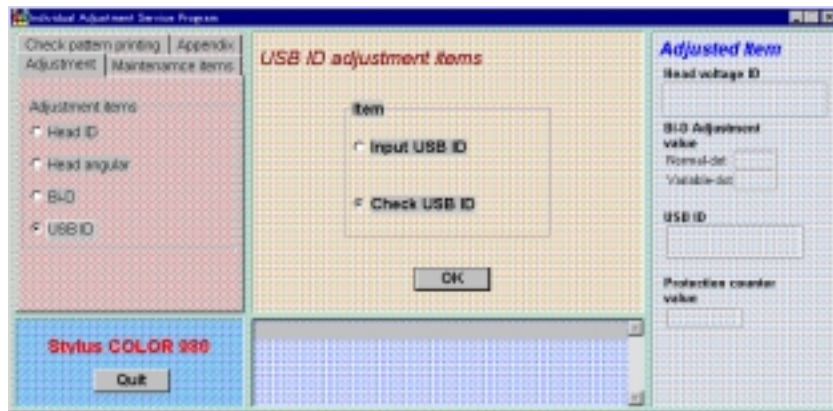

Figure 5-13. USB ID Input / Check Selection Screen

4. Select "Input USB ID".
5. Click "OK".
6. The following screen appears.

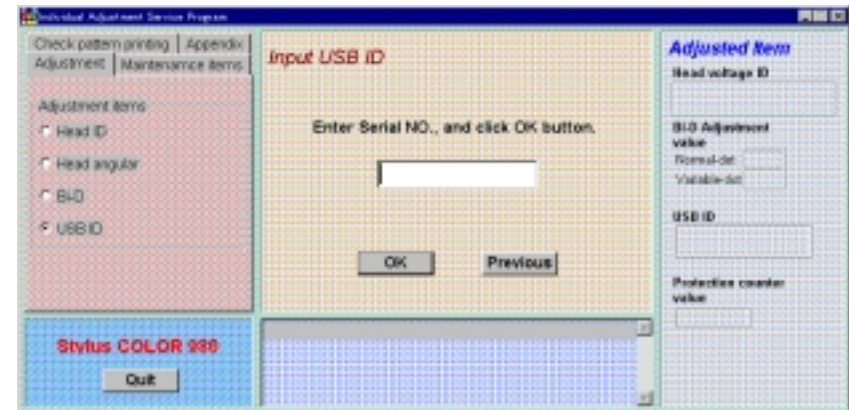

Figure 5-14. USB ID Input Screen

7. Type the USB ID.
8. Click "OK".
9. The following screen appears.

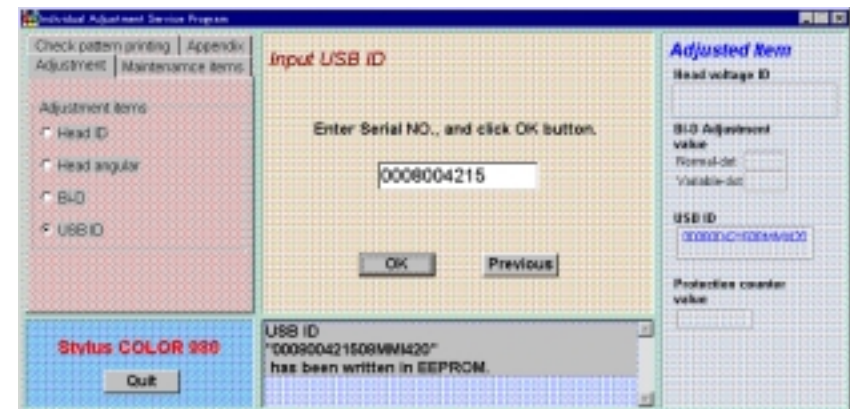

Figure 5-15. Screen after USB ID Input

5.2.7 USB ID Retrieval

This section describes the procedure of USB ID retrieval.

1. Perform the operation of USB ID Input (5.2.6) 1-3.
2. Select “Check USB ID”.
3. Click “OK”.
4. The following screen appears.

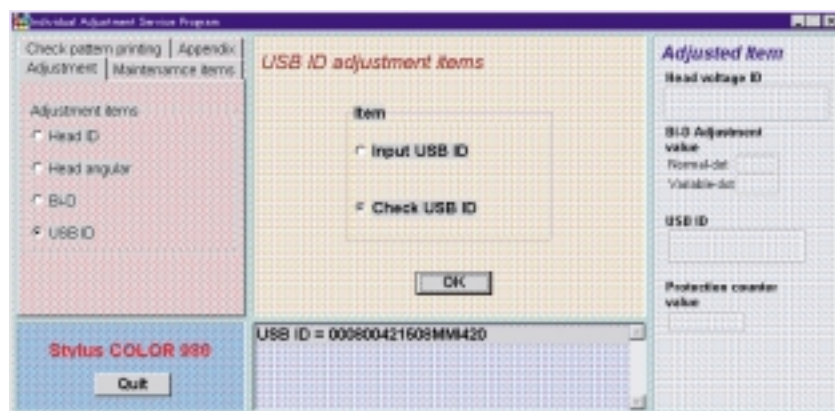

Figure 5-16. Check USB ID Screen

5.2.8 Printhead Cleaning Using the Program

The service program for the Stylus Color 980 has the cleaning function. The command is always executed with the most powerful cleaning mode. Note the printer is not equipped with the dummy cleaning called CL3. Therefore, you can attempt to solve the nozzle clogging problem by pressing the Cleaning button on the control panel repeatedly.

1. Referring to Section 5.2.1, perform the preliminary operation.
2. Select "Maintenance items" from the main adjustment menu.
3. Select "Head Cleaning".
4. The following screen appears.

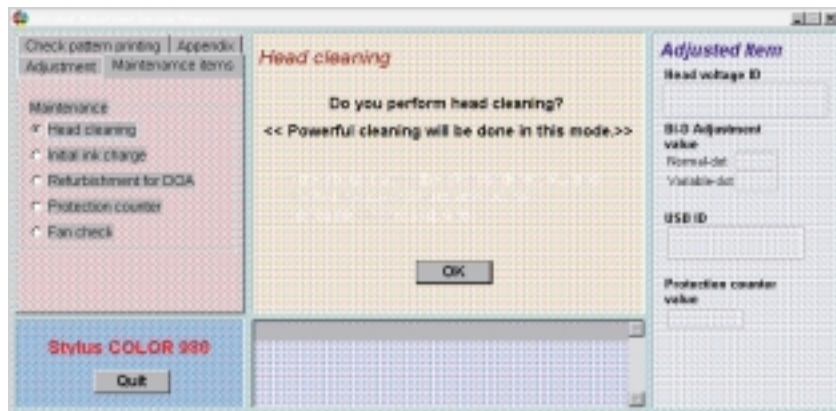

Figure 5-17. Main maintenance Menu Screen

5. Click "OK".

6. The following screen appears.

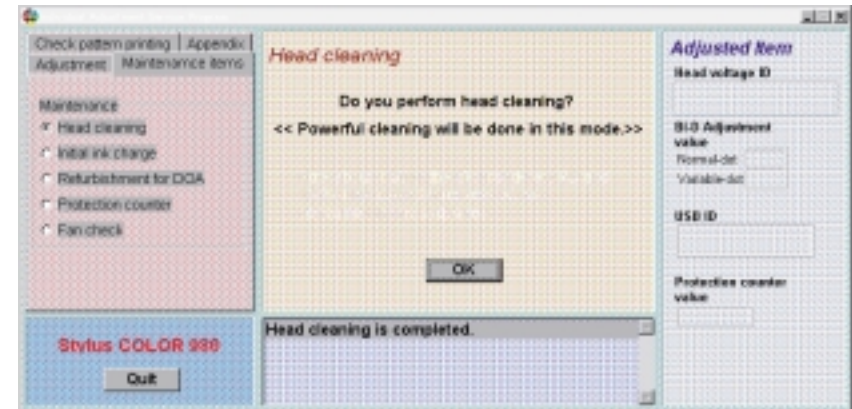

Figure 5-18. Cleaning Screen

7. Head cleaning is start.

5.2.9 Initial Ink Charge

This section describes how to perform Initial Ink Charge. It must be performed under the following conditions.

1. C380 Main Board has been replaced.
 2. The printhead has been removed. (Be sure to perform Ink Cartridge Replacement Sequence before performing Initial Ink Charge.)
 3. Nozzles are badly clogged. (Cleaning using the program and control panel has been done, but the nozzles are still clogged.)
1. It is advisable that the currently installed ink cartridges be replaced with new ones. (If ink runs out during the operation, Initial Ink charge begins again when a new I/C is installed.)
 2. Referring to Section 5.2.1, perform the preliminary operation.
 3. Select "Maintenance items" from the main adjustment menu.
 4. Select "Initial Ink Charge".
 5. The following screen appears.

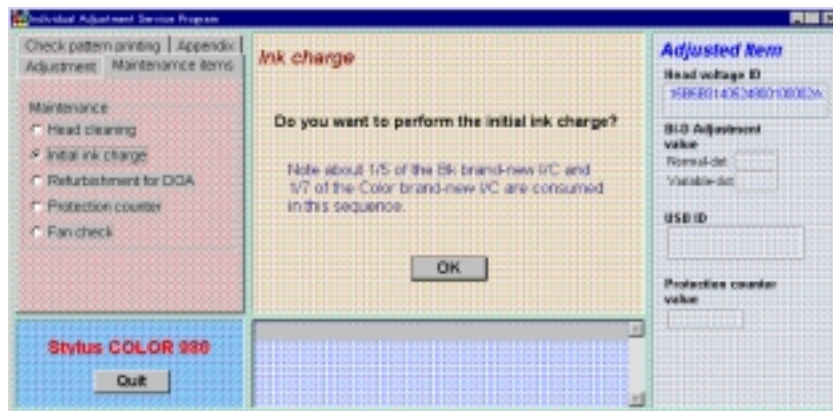

Figure 5-19. Screen after "Initial Ink Charge" is Selected

6. Click "OK".
7. The following screen appears.



Figure 5-20. Message during Ink Charge Flag Reset Operation

8. Turn the printer off.
9. Leave the printer as it is for 10 seconds.
10. Turn the printer back on. The printer performs Initialization and then Initial Ink Charge in sequence.

5.2.10 Refurbishment for DOA

TBD

5.2.11 Indication of the Counter Value for the Waste Ink Pad

This section describes how to indicate and clear the values for the waste ink pad counters (protection counters) which shows the total ink amount absorbed in the waste ink pads. In case of Stylus Color 980, you can confirm and reset the counter values through the printer's control panel operation only. This manual, however, only describes the procedure using the service program.

1. Referring to Section 5.2.1, perform the preliminary operation.
2. Select "Maintenance items" from the main Adjustment menu.
3. Select "Protection counter".
4. The following screen appears.



Figure 5-21.

Initial Protection Counter Screen - Check/Clear Selection

5. Select "Check the present counter values".
6. Click "OK".

7. The following screen appears.

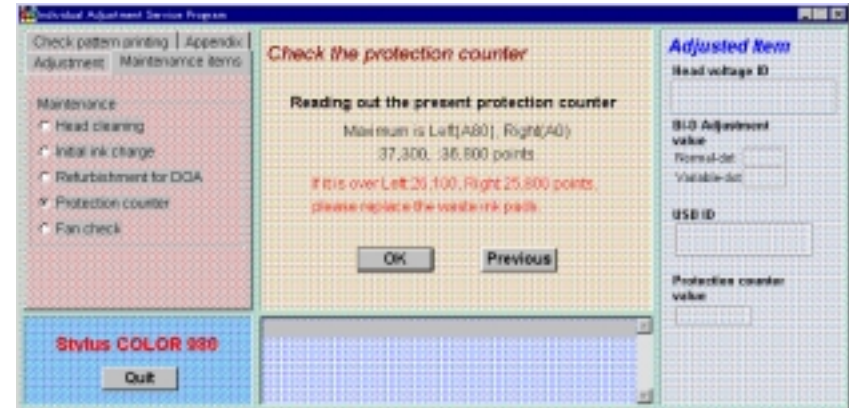

Figure 5-22. Protection Counter Indication Screen

8. Click "OK".

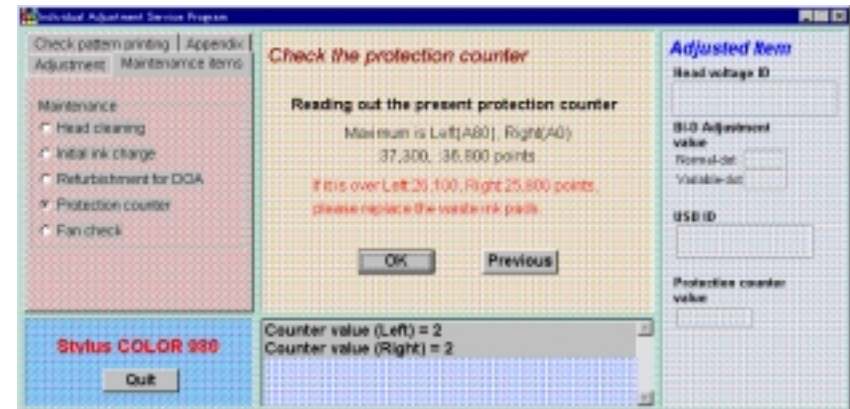

Figure 5-23. Screen After "OK" is Clicked

9. The maximum values for the left and right pads are 37,300 and 36,800 points, respectively. If it is over Left 26,100, Right 25,800 points, please replace the waste ink pad.

NOTE:

Before clearing the protection counters, be sure to replace the waste ink pads with new ones. Otherwise, the user may encounter ink leakage.

10. Disconnect the printer from the PC and replace the waste ink pads with new ones, referring to Chapter 6 “Maintenance”.
11. Referring to Section 5.2.1, perform the preliminary operation. Then select “Maintenance items” from the main adjustment menu and next “Protection counter”.
12. Select “Clear the Protection Counter Value”.
13. Click “OK”.
14. The following screen appears.



Figure 5-24.

Selection Menu before Clearing the Protection Counter

15. Click “OK”.

16. The following screen appears.



Figure 5-25. Protection Counter Clear End Screen

17. Click “Previous” to return to the initial protection counter screen (Figure 5-21).
18. Select “Check Protection Counter” to verify the right and left ink pad counter values are both “0”.

5.2.12 Fan Check

This program enables you to check the fan's operational condition. In the Stylus Color 980, the fan does not necessarily rotate when the printer is turned on. Therefore, if the Head Hot Error (indication on the panel: Ink Out Error) occurs frequently, the fan must be checked for its condition.

1. Referring to Section 5.2.1, perform the preliminary operation.
2. Select "Fan Check" from the main maintenance menu.
3. The following screen appears.



Figure 5-26. Screen after "Fan Check" is Selected

4. As the screen (Figure 5-26) appears, the cooling fan starts rotating. If the fan is rotating properly, select "Yes", and the fan stops rotating.
5. If "No" is selected because the fan does not rotate, the following screen appears. In this case, refer to the Service Manual / Chapter 3 "Troubleshooting" / "Fan does not rotate", as the message prompts.

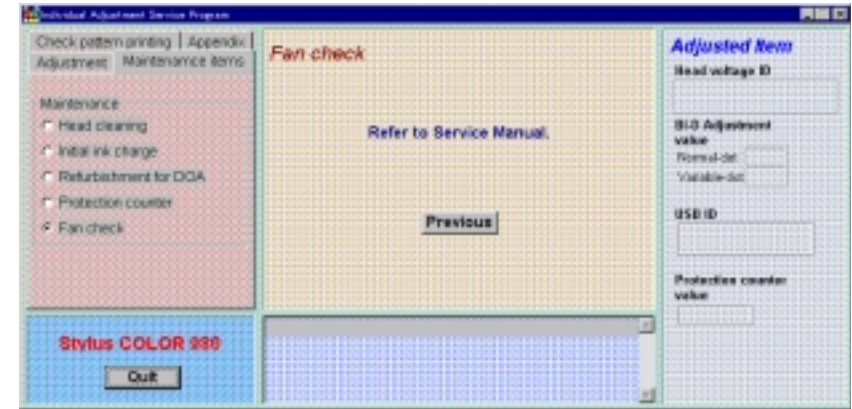

Figure 5-27.
Screen after "No" is Selected due to Fan's Malfunction

5.2.13 Paper Gap Adjustment

Paper Gap Adjustment is performed to provide a proper gap between the printhead surface and paper surface. It must be made under the following conditions. (This adjustment can not be made without removing the upper case.)

1. Any of the following operations which involve carriage guide shaft removal has been performed.
 - Replacing the carriage guide shaft
 - Replacing the felt oil pad at the back of the carriage (when supplying O-8 oil)
 - Replacing the carriage unit
2. Right/left parallelism adjustment bushing has been moved, removed or replaced.
1. Set the right and left parallelism adjustment bushings to the middle position of the corresponding adjustable range. Make sure the screws fixing the parallelism adjustment bushings are loosened for this operation.

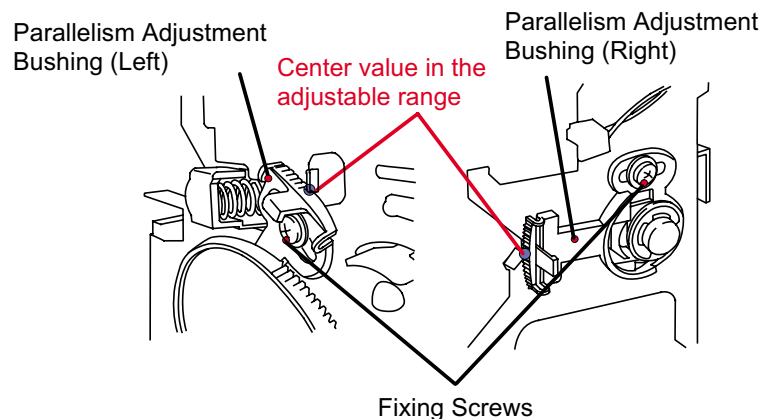

Figure 5-28.

Right and Left Parallelism Adjustment Bushing Locations

2. Install dummy cartridges (empty cartridges) and close the both clamps.
3. Set the PG lever (blue) to the rear (PG = wider).
4. If the carriage is locked, release the carriage lock from the back of the printer mechanism.
5. Move the carriage to the center and place the thickness gauge (Specifications: 1.14 mm, 5 cm in length) over the right end of the Front Paper Guide's top surface.

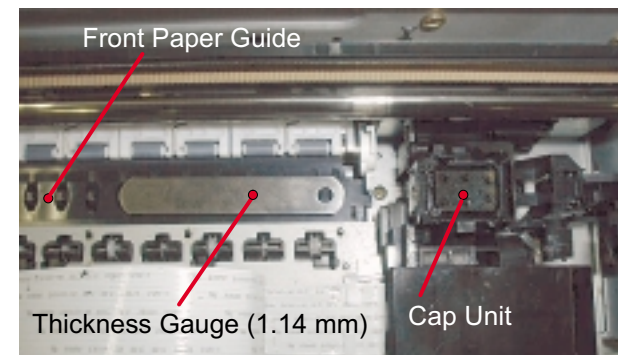

Figure 5-29. Setting Position of the Thickness Gauge

6. Bring the PG lever (blue) back to the front (PG = narrower).
7. By pulling the timing belt manually, move the carriage to the position where the thickness gauge is set.

NOTE:

Do not push the carriage unit directly to move it. Doing so presses the carriage down and the paper gap adjustment is not correctly done.

8. When the printhead is in contact with the thickness gauge, check if the thickness gauge moves.

9. If the thickness gauge does not move, move the right parallelism adjustment bushing upward by one notch. The direction for moving the bushing and corresponding change in PG amount is as shown in the following figure.

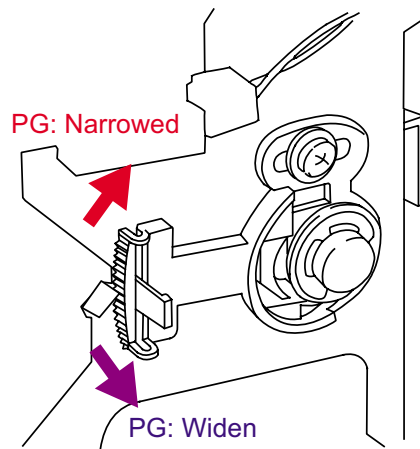

Figure 5-30.

Bushing's Movement and Corresponding Change in PG Amount

NOTE:

Be sure to release the parallelism adjustment bushing (right/left) from the frame before turning it. Otherwise, the teeth may crush and the adjustment can not be done.

10. Repeat the steps from 3 to 9 until the thickness gauge moves being pushed by the printhead.
11. When the thickness gauge starts moving, move the carriage away from the thickness gauge set by pulling the timing belt. (The carriage moves back to the left.)
12. Push the right parallelism adjustment bushing down from the current position by one notch.

13. By pulling the timing belt, move the carriage again to the position where the thickness gauge is set and make sure the thickness gauge does not move.
14. Place the thickness gauge on the 80th column position and adjust the with the left parallelism adjustment bushing in the same manner as for the right parallelism adjustment bushing.

NOTE:

Make sure the PG lever (blue) is set properly depending on the operation as shown below:

- *During the adjustment:
Set to the front (PG = narrower)*
- *When moving the carriage away from the thickness gauge:
Set to the rear (PG = wider)*

15. Set the PG lever (blue) to the rear (PG = wider).
16. Place the thickness gauge on the right side of the rib in the Front Paper Guide again.
17. Set the PG lever (blue) to the front (PG = narrower).
18. By pulling the timing belt manually, move the carriage to the position where the thickness gauge is set and make sure the thickness gauge does not move.
19. Turn the right parallelism adjustment bushing upward by one notch and ensure the thickness gauge moves.
20. Return the right parallelism adjustment bushing to the previous position by turning it downward by one notch.
21. If the results of the steps 18 and 19 are incorrect, make the PG adjustment using the left bushing again.

22. Holding the right parallelism adjustment bushing with your hand so it does not move, fasten the screw.
23. Holding the left parallelism adjustment bushing with your hand so it does not move, fasten the screw.
24. Remove the thickness gauge.
25. If the linear scale is dislocated, set it through the photo sensor at the back of the carriage.
26. Move the carriage to the right.
27. Install the upper case.

CHAPTER

6

MAINTENANCE

6.1 Overview

This section describes how to solve problems when a printing malfunction or maintenance request error has occurred. Observe the instructions below to perform servicing appropriately. For solutions for any other error conditions, refer to Chapter 3 “Troubleshooting”.



This C380 Main board in this printer has a lithium battery on it. Observe the instructions below when handling the battery.

- Do not short-circuit the battery’s electrodes.
- Mount the battery with its polarity in the right direction, or it may explode.
- Do not expose the battery to flames or excessive heat.



- Unplug the power cable from the AC power inlet before cleaning the printer.
- Never apply solvents such as thinner, trichloroethylene, or ketone to clean the printer main body. Use of a soft clean cloth is recommended. For severe stain on the case, use thinned neutral detergent. Wet a cloth with detergent and wring the detergent well out of the cloth.
- Do not use a hard brush for cleaning, or it may scratch the case.
- Be careful no to damage any interior parts when cleaning inside the printer.

6.1.1 Maintenance

When a printing malfunction or Maintenance request error has occurred, take appropriate measures described in the following sections to solve the problem.

6.1.1.1 Cleaning the Printhead

If your printout shows problems such as white banding, color banding, dot missing, or improper ink ejection (bad alignment), the printhead needs to be cleaned. The cleaning methods equipped with the Stylus Color 980 are as shown in Figure 6-1.



If printing results get worse all the more you repeat cleaning, it is assumed that the ink cartridge has run out the ink and the ink consumption counter is upset due to a user's mishandling the ink cartridge. In this case, enter the ink cartridge replacement sequence and replace the installed ink cartridge with a new one.

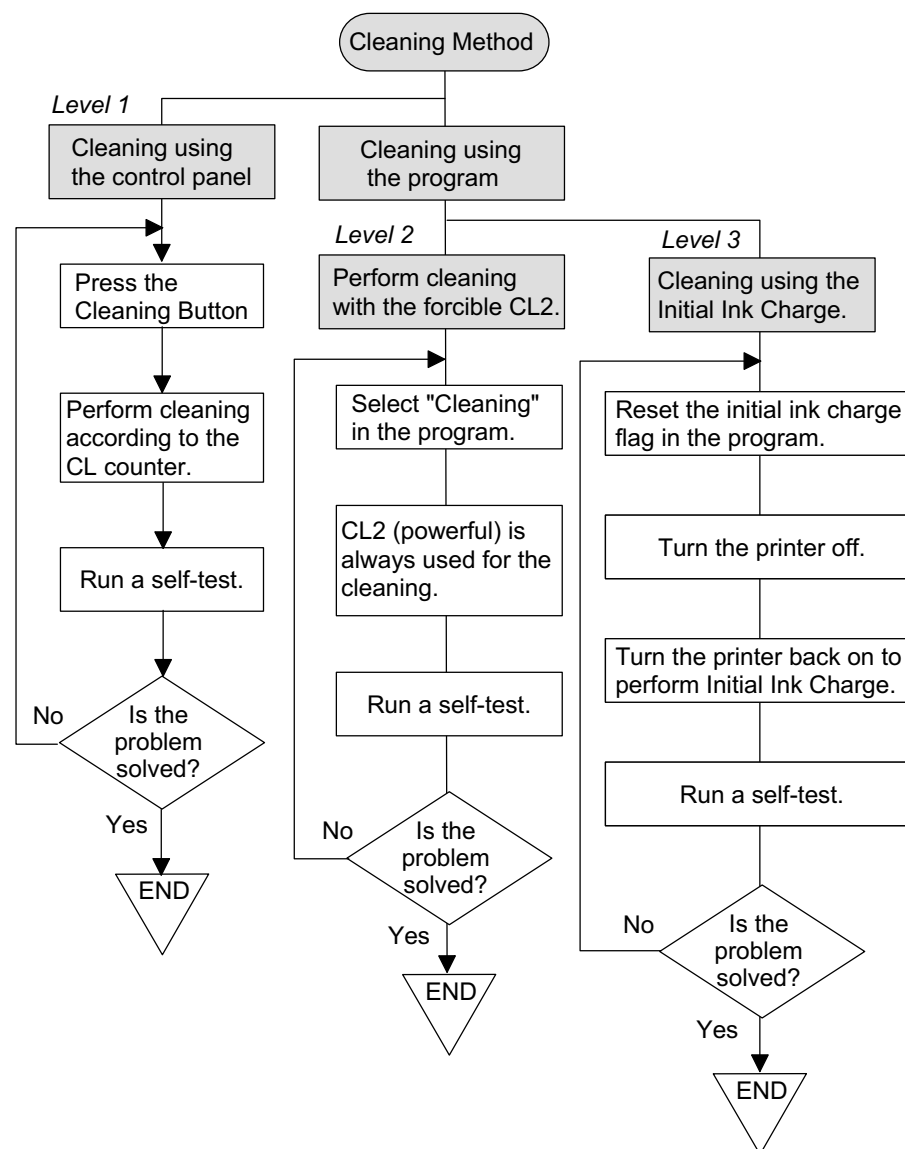

Figure 6-1. Printhead Cleaning Options

6.1.1.2 Maintenance Request Error

The Maintenance Request Error is indicated when the waste ink absorber located in the lower case becomes near full. The table below shows methods and procedures necessary to clear the Maintenance Request Error.

Table 6-1. Solution for the Maintenance Request Error

No.	Options	Description	Reference
1	Using the control panel	<ul style="list-style-type: none"> Reset waste ink counter. <p>NOTE: <i>Unlike other printers, the waste ink counter reset operation is not common to Timer IC nor I/F selection reset.</i></p>	Chapter 1 / Section 1.4
2	Using the program	<ul style="list-style-type: none"> Waste ink count reset 	Chapter 5 / Section 5.2.8.



- **Be sure to replace the waste ink pads before or after clearing the Maintenance Request Error. Otherwise, your customer may encounter ink overflow.**
- **The maximum counter value for each pad is as follows:**
Left pad: 35800, Right pad: 33300
 However, the adjustment program urges to set 25800 (left) and 23,300 (right) as a reference values for pad replacement. (10,000 points is deducted from each maximum value.)

6.2 Lubrication and Adhesion

The types lubricants used in the Stylus Color 980 are specified by SEIKO EPSON. Lubricate the printer if necessary under the following conditions;

- Oil has been wiped off during cleaning.
- Printer has been disassembled/assembled.
- Specific part(s) in the printer has been replaced.

For a specific feature of ink jet printers, an oil pad(s) must be lubricated with a special care. Observe the instructions below and perform lubrication by strictly following the specified lubricants type, amount, and the way to apply.



- **Never add oil to the currently used oil pad.** Be sure to supply specified amount of oil to a new oil pad. Otherwise, too much oil will be absorbed, which damages the printhead.
- Pay special attention in handling “O8” so the printhead is not smeared with it.
- Never apply oil directly to the carriage shaft guide. **Be sure to remove the printhead unit and the carriage unit before** replacing the current oil pad with a new one and then supplying oil to the new pad. Accordingly, you need to perform any necessary head related adjustment. (Refer to Chapter 5.)



- When installing the carriage guide shaft after oiling the oil pad, **be sure to clean the shaft and perform the preliminary lubrication before installing the shaft as described below:**
 1. Using a dry cotton cloth, wipe off the oil on the carriage guide shaft surface well to remove dirt completely.
 2. Using the dry cotton cloth, clean the inner surfaces of the metallic bushings on the carriage unit through which the shaft is inserted. (To remove iron pieces)
 3. Get a new oil pad and supply “O8” (0.5 cc) into it.
 4. Using the oiled side of the pad, lubricate over the whole surface of the carriage guide shaft well.
 5. Install another new oil pad to the specified position at the back of the carriage.
 6. Supply specified amount of “O8” (0.7 cc to 0.75 cc) to the installed oil pad. Make sure the printhead has been removed for this operation.

NOTE: For precise oil control, use the smallest-diameter syringe available. Also, never use the syringe without a needle on it.

6.2.1 Lubricating the Carriage Guide Shaft

This section includes the procedure for lubricating the carriage guide shaft. Unlike other models, the lubrication of the carriage guide shaft is performed under many restrictions. Therefore, be sure to observe the CAUTION in the previous section and perform lubrication by strictly following the steps specified.

1. Remove the printhead. (Refer to 4.2.7.1.)
2. Remove the carriage unit. (Refer to 4.2.7.10.)
3. Clean the carriage shaft by wiping the shaft's surface with a dry cloth.

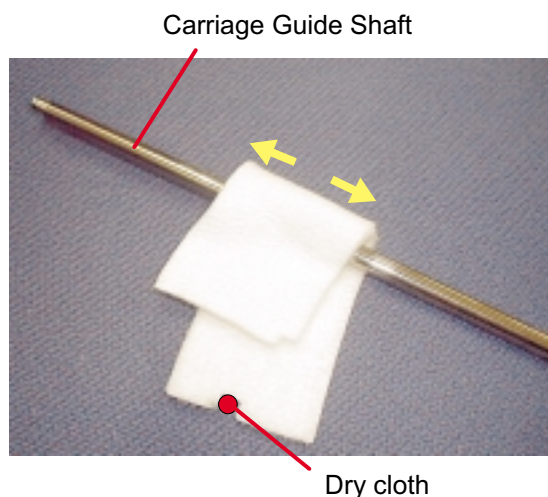

Figure 6-2. Cleaning the Carriage Guide Shaft

4. Remove the Oil Pad (a felt pad) from the back of the carriage unit.

5. Using the dry cloth, completely wipe the inner surfaces of the 2 metallic bushings through which the carriage guide shaft is set. Especially, wipe well off black stains if any. Also, clean the portion where the pad was attached using the cloth.

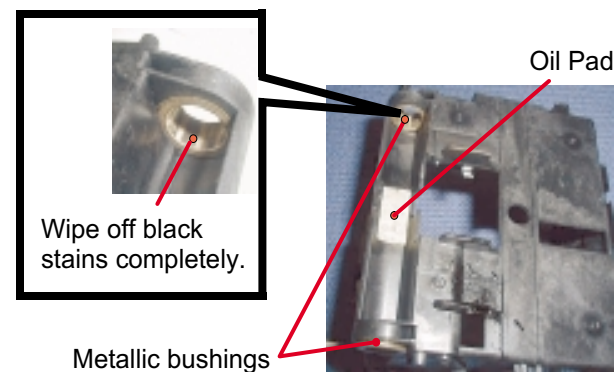

Figure 6-3. Locations for Oil Pad and Bushings

6. Get a smallest-diameter syringe available. The small syringe shown below only contains 2 cc maximally.

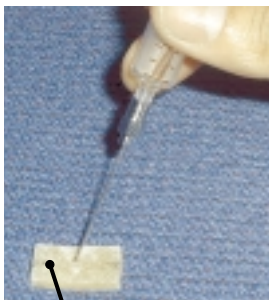

Figure 6-4. Small Syringe



Be sure to use a small-diameter syringe to minimize the tolerance. Small syringe allows you to see pushed amount (stroke) more clearly.

7. Get 2 new oil pads.
8. To one of the new oil pads, supply "O8" (0.5 cc) using the small syringe.



Supply "O8" (0.5 cc) to the oil pad.

Figure 6-5. Supplying Oil to the Oil Pad (1)

9. Using the oiled side of the pad (step 8), lubricate the carriage guide shaft surface thoroughly.



Figure 6-6. Preliminary Lubrication with "O8"

10. Install the other new oil pad to the specified position at the back of the carriage.

11. Using the same syringe used in Step 8, supply "O8" (0.7 to 0.75 cc) to the installed oil pad.

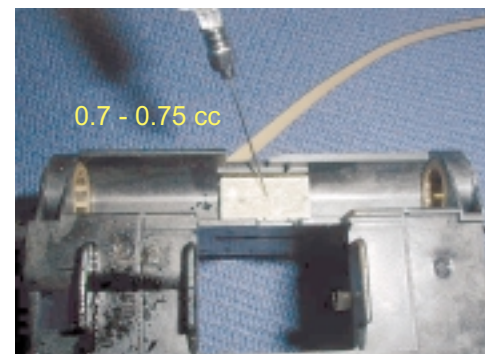

Figure 6-7. Supplying Oil to the Oil Pad (2)

12. Install the carriage guide shaft to the carriage unit then to the printer main body. (See Chapter 4 / Section 4.2.7.10.)
13. Install the printhead. (See Chapter 4 / Section 4.2.7.1.)
14. Perform Paper Gap Adjustment. (See Chapter 5 / Section 5.2.10.)
15. Turn the printer on without the ink cartridges installed to cause the Ink Cartridge Out Error.
16. Using the Load/Eject button, run the Ink Cartridge Replacement Sequence and install new ink cartridges.
17. Using the service program, perform Initial Ink Charge. (See Chapter 5 / Section 5.2.7.)
18. Perform Head Angular Adjustment. (See Chapter 5 / Section 5.2.4.)
19. Perform Bi-Directional Adjustment. (See Chapter 5 / Section 5.2.5.)

Table 6-2. Oil Applied to the Stylus Color 980

Type	Part name	Content	Part code	Availability
Grease	G-26	40g	B702600001	EPSON exclusive
Oil	O-8	40g	1019753	EPSON exclusive

NOTE: No adhesion is used in the Stylus Color 980.

Table 6-3. Lubrication Points Using G-26

No.	Lubricating Point	Amount	Ref. figure
1	Using a brush, lubricate the whole inner surface of the round cutout in the right side of the [Frame,ASF;B].	φ1 x 1 mm	Figure 6-8
2	Using a brush, lubricate right and left sides of the [Hopper ASSY, C].	φ1 x 2 mm	Figure 6-9
3	Lubricate the inner gear of the [Combination gear,14.4, 24].	φ1 x 1 mm	Figure 6-10
4	Lubricate the surface of the bearing part (the round cut) of the [Bushing,12] located at the right end of the printer mechanism.	φ1 x 10 mm	Figure 6-11
5	Lubricate the [Shaft, Pulley, Driven].	φ1 x 1 mm	Figure 6-12
6	Lubricate the back of the [Frame, Guide, CR].	φ1 x 150 mm	Figure 6-13

Table 6-4. Lubrication Point Using the O-8

No.	Lubricating Point	Amount	Ref. figure
1	Apply oil to the [Oil Pad]. Before lubricating, observe the CAUTION in Section 6.2 well.	0.7 - 0.75 cc	Figure 6-14

Table 6-5. Lubrication Points

No.	Lubricating Point	Amount
1	The shaft in the [Frame Assembly, DE, Right]	G-26 (φ1 x 10 mm)
2	The teeth of the [Gear, 25.8]	G-26 (φ1mm x 1/3 of the circle)
3	The shaft in the [Frame Assembly, DE, Left]	G-26 (φ1 x 10 mm)
4	The teeth of the smaller gear in the [Combination Gear,12, 26]	G-26 (φ1mm x 1/3 of the circle)
5	12 points on the [Paper Guide,Front]	G-26 (φ1 x 2 mm)
6	4 points in the [Grounding Plate,Paper Eject]	G-26 (φ1 x 2 mm)
7	2 contact areas; between [Roller Assembly,Paper Eject, Rear] and [Grounding Plate, Eject]	G-26 (φ1 x 2 mm)
8	2 contact areas; [Roller Assembly, Eject] and [Grounding Plate, Eject]	G-26 (φ1 x 2 mm)
9	The teeth of the right and left [Gear,27]s	G-26 (φ1mm x 1/4 of the circle)
10	2 points on the shaft in the [Lever Assembly, Release,Cam] NOTE: Do not apply lubricant to the roller surface.	G-26 (φ1 x 2 mm)
11	[Oil Pad] Refer to Section 6.2.1 "Lubricating the Carriage Guide Shaft".	O-8 (0.7 - 0.75 cc)
12	A hole in the [Frame Assembly, Middle, Left]	G-26 (φ1 x 3 mm)
13	Roller shaft in the [Lever Assembly, Roller Release, Right]	G-26 (φ1 x 1 mm)
14	Pin on the [Frame, Middle, Right]	G-26 (φ1 x 3 mm)
15	Narrow end of the [Shaft, Arm Lifter]	G-26 (φ1 x 2 mm)

Table 6-6. Lubrication Points (continued)

No.	Lubricating Point	Amount
16	U-shape grooves on the right and left edges of the [Paper Guide Front Unit].	G-26 ($\phi 1 \times 5$ mm, top and bottom)
17	The surface of the [Shaft, CR] NOTE: Do not apply lubricant to the [Shaft, CR, Support].	O-8
18	Shaft hole of the [Combination Gear, 29.6, 29.6]	G-26 ($\phi 1 \times 5$ mm)
19	The areas where the [Combination Gear, 29.6,29.6] and [Combination Gear, 15.2,23.2] come in contact with the [Mounting Plate Assembly, Cap]. NOTE: Do not apply lubricant to the shaft of the [Combination Gear, 15.2, 23.2] which joins with the hole in the [Pump Assembly].	G-26 ($\phi 1 \times 5$ mm)

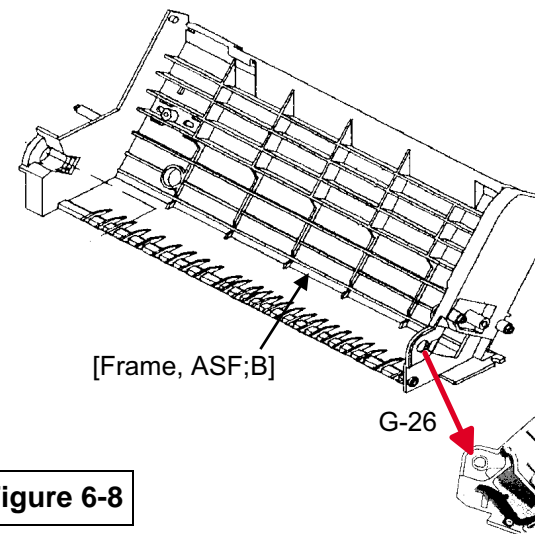

Figure 6-8

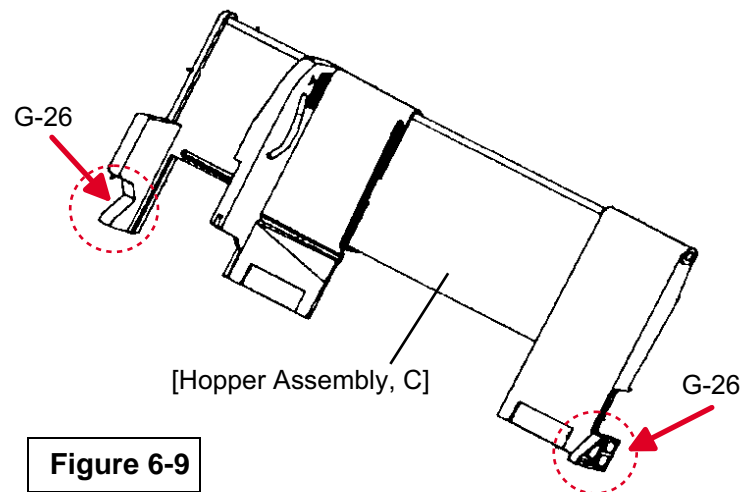

Figure 6-9

Figure 6-10

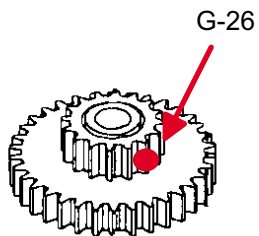
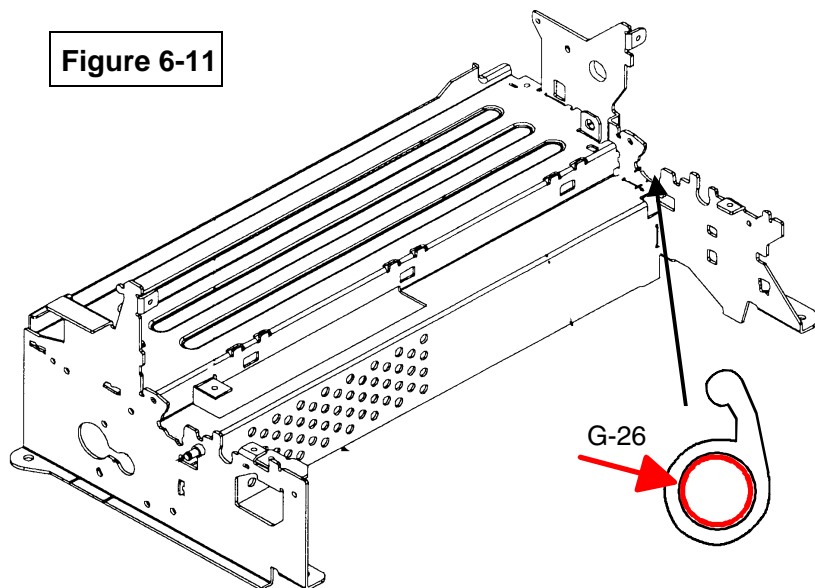

Figure 6-11



[Shaft, Pulley, Driven] G26 Figure 6-12

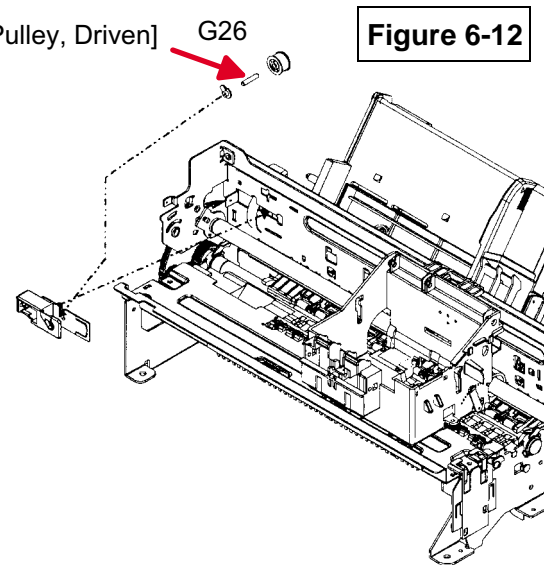

Figure 6-13

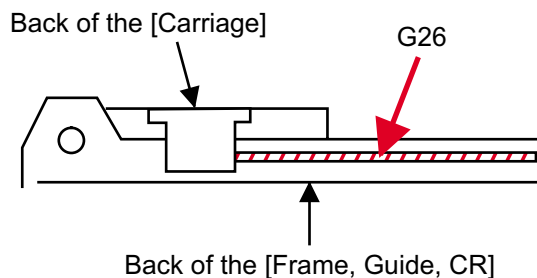
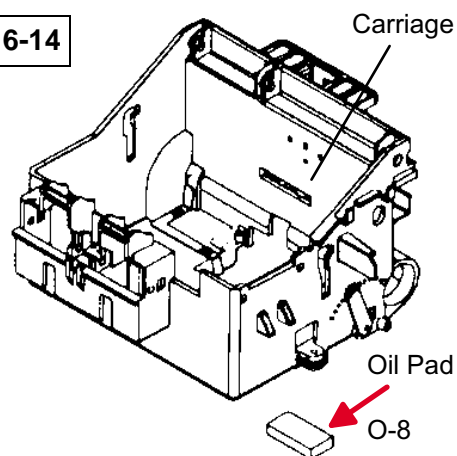

Figure 6-14



CHAPTER

7

APPENDIX

7.1 Connector Summary

Figure 7-1 shows the cable connection of the Stylus Color 980.

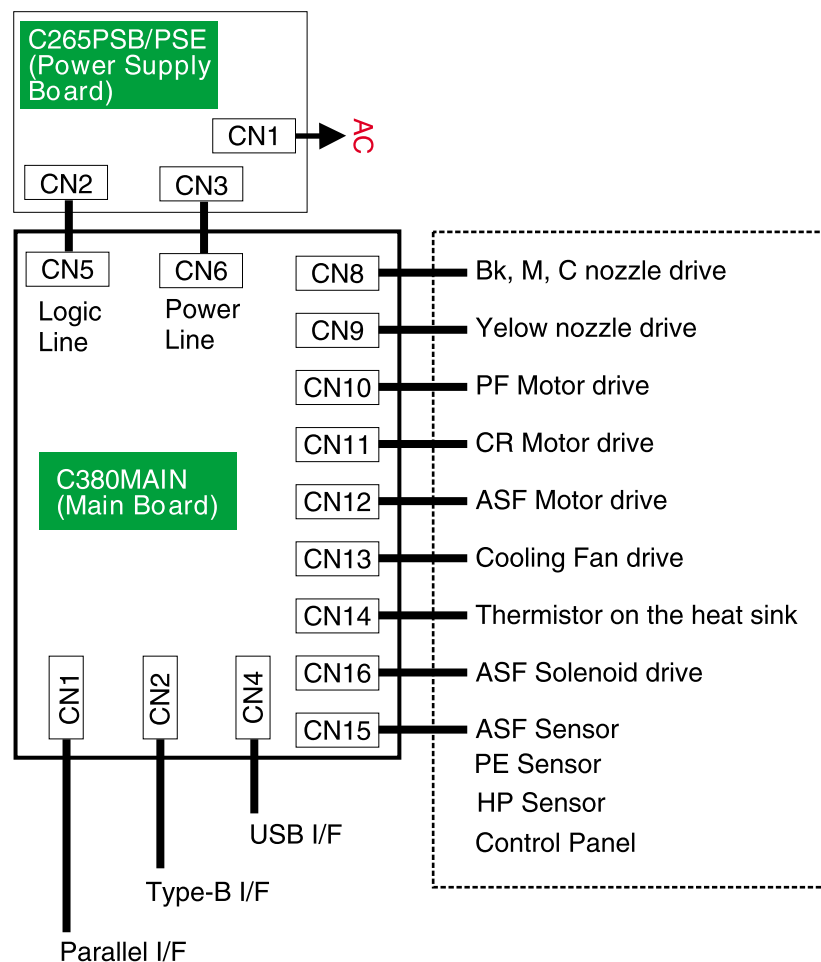

Figure 7-1. Cable Connection of the Stylus Color 980

Table shows the connector assignment of the C380 Main Board.

Table 7-1. C380 Main Board Connections

Connector	Function	Refer to:
CN1	Parallel I/F connector	Chapter 1 / Interface specifications
CN2	Type-B I/F connector	Type-B I/F Manual
CN4	USB I/F connector	Chapter 1 / Interface specifications
CN5	Power supply (Logic line)	Table 7-2
CN6	Power supply (Power line)	Table 7-3
CN7	----	----
CN8	Bk, Magenta, Cyan nozzle drive	Table 7-4
CN9	Yellow nozzle drive	Table 7-5
CN10	PF motor drive	Table 7-6
CN11	CR motor drive	Table 7-7
CN12	ASF motor drive	Table 7-8
CN13	Cooling fan drive	Table 7-9
CN14	Thermistor on the heat sink	Table 7-10
CN15	Panel and Sensors (HP, PE, ASF)	Table 7-11
CN16	ASF solenoid drive	Table 7-12

Table 7-2. Connector Pin Assignment - CN5

Pin	Signal Name	I/O	Function
1, 7	GND	----	Ground
2, 3, 5, 6	5 V	I	+5 voltage supply
4	PSC	I	Delay control at power off

Table 7-3. Connector Pin Assignment - CN6

Pin	Signal Name	I/O	Function
1, 6	GND	---	Ground
2, 3, 4, 5	+42 V	I	+42 voltage supply

Table 7-4. Connector Pin Assignment - CN8

Pin	Signal Name	I/O	Function
1	ANODE1	I	Row A temperature detection analog signal
2	ANODE2	I	Row A temperature detection analog signal
3	GND2A	---	Ground for the Nozzle Row A
4	GND2A	---	Ground for the Nozzle Row A
5	COMa	O	Power voltage for the Nozzle Row A (black)
6	COMb	O	Power voltage for the Nozzle Row A (black)
7	GND2B	---	Ground for the Nozzle Row B nozzles
8	GND2B	---	Ground for the Nozzle Row B nozzles
9	ANODE3	I	Row C (Cyan) temperature detection analog signal
10	ANODE4	I	Row D (Magenta) temperature detection analog signal
11	GND2C	---	Ground for the Nozzle Row C
12	GND2C	---	Ground for the Nozzle Row C
13	COMc	O	Power voltage for the Nozzle Row C
14	COMd	O	Power voltage for the Nozzle Row D
15	GND2D	---	Ground for the Nozzle Row D
16	GND2D	---	Ground for the Nozzle Row D
17	VHV	O	Power supply for the comparator (Nozzle Selector)
18	GND	---	Ground
19	TH	I	Analog data from the thermistor on the printhead
20	LS2	I	Phase B signal from the linear encoder
21	LS1	I	Phase A signal from the linear encoder

Table 7-5. Connector Pin Assignment - CN9

Pin	Signal Name	I/O	Function
1	COMe	O	Power voltage for the Nozzle Row E (Yellow)
2	GND2E	---	Ground for the Nozzle Row E
3	GND2E	---	Ground for the Nozzle Row E
4	ANODE5	I	Row E temperature detection analog signal
5	B2	O	Outputs dot selection signal to the Row B (black)
6	GND	---	Ground
7	B1	O	Outputs dot selection signal to the Row A (black)
8	GND	---	Ground
9	C	O	Outputs dot selection signal to the Cyan row
10	GND	---	Ground
11	M	O	Outputs dot selection signal to the Magenta row
12	GND	---	Ground
13	Y	O	Outputs dot selection signal to the Yellow row
14	GND	---	Ground
15	CLK	O	Synchronization clock signal for dot selection signal transmission
16	GND	---	Ground
17	LAT	O	Latch signal to inform of a dot selection signal transfer completion
18	GND	---	Ground
19	INV	O	Inversion signal of the print data (High without data)
20	COB	I	Black ink cartridge In/Out detection signal
21	COC	I	Color ink cartridge In/Out detection signal

Table 7-6. Connector Pin Assignment - CN10

Pin	Signal Name	I/O	Function
1	PF A	I/O	Phase A Input/Output data When inputting, connects a current from the Phase -A to the ground via the coil.
2	PF B	I/OB	Phase B Input/Output data When inputting, connects a current from the Phase -B to the ground via the coil.
3	PF -A	I/O	Phase -A Input/Output data When inputting, connects a current from the Phase A to the ground via the coil.
4	PF -B	I/O	Phase -B Input/Output data When inputting, connects a current from the Phase B to the ground via the coil.

Table 7-7. Connector Pin Assignment - CN11

Pin	Signal Name	I/O	Function
1	CR A	I/O	Phase A Input/Output data When inputting, connects a current from the Phase -A to the ground via the coil.
2	CR B	I/O	Phase B Input/Output data When inputting, connects a current from the Phase -B to the ground via the coil.
3	CR -A	I/O	Phase -A Input/Output data When inputting, connects a current from the Phase A to the ground via the coil.
4	CR -B	I/O	Phase -B Input/Output data When inputting, connects a current from the Phase B to the ground via the coil.

Table 7-8. Connector Pin Assignment - CN12

Pin	Signal Name	I/O	Function
1	ASF A	I/O	Phase A Input/Output data When inputting, connects a current from the Phase -A to the ground via the coil.
2	ASF B	I/O	Phase B Input/Output data When inputting, connects a current from the Phase -B to the ground via the coil.
3	ASF -A	I/O	Phase -A Input/Output data When inputting, connects a current from the Phase A to the ground via the coil.
4	ASF -B	I/O	Phase -B Input/Output data When inputting, connects a current from the Phase B to the ground via the coil.

Table 7-9. Connector Pin Assignment - CN13

Pin	Signal Name	I/O	Function
1	+35V	O	Power supply for driving the fan
2	GND	---	Ground

Table 7-10. Connector Pin Assignment - CN14

Pin	Signal Name	I/O	Function
1	THM1	I	Analog signal for the temperature detection of the heat sink surface on the main board.
2	THM2	---	Ground

Table 7-11. Connector Pin Assignment - CN15

Pin	Signal Name	I/O	Function
1	GND	---	Ground
2	GND	---	Ground
3	SW0	I	Detects the power SW condition.
4	PSC	O	Charging voltage to the electrolysis condenser for the delay control
5	SW1	I	Detects the Load/Eject SW condition
6	SW2	I	Detects Cleaning SW condition
7	LED0	O	Power LED drive signal
8	LED1	O	Color ink Near Empty or perfect out LED drive signal
9	LED2	O	Paper Out Error LED drive signal
10	LED3	O	Black Ink Near Empty or perfect out LED drive signal
11	+5V	O	Power supply for the LED/PE sensor
12	+5V	O	Power supply for the LED/PE sensor
13	GND	---	Ground
14	ASF	I	ASF sensor condition detection signal
15	PE	I	PE sensor condition detection signal
16	HP	I	HP sensor condition detection signal
17	PEVCC	O	Power supply for the PE sensor drive
18	HPVCC	O	Power supply for the HP sensor drive

Table 7-12. Connector Pin Assignment - CN16

Pin	Signal Name	I/O	Function
1	VBB	O	Power supply voltage for the solenoid excitation (42V)
2	GND	---	Ground

7.2 EEPROM ADDRESS MAP

This section contains the EEPROM map for the Stylus Color 980.

Table 7-13. EEPROM Address Map (1/8)

Address	Explanation	Settings	QPIT settings	Factory settings
00H	Password 0		0FH	–
01H			5AH	–
02H	EEPROM mapping revision		41H	–
03H	reserved		00H	–
04H	CG	0: STD 1: NLSP	00H	(*1)
05H	Market ID	0: Standard (World) 1: Custom	00H	(*1)
06H, 07H, 08H, 09H	Custom EEPROM sub number		00H	00H
0AH	Head actuator rank ID for VhN		00H	(*1)
0BH	reserved		00H	–
0CH	reserved		00H	–
0DH	Head actuator rank ID for VhL		00H	(*1)
0EH	Head actuator rank ID for VhU		00H	(*1)
0FH	Head actuator rank ID for VhM		00H	(*1)
10H	reserved for Head-ID		00H	(*1)
11H	reserved for MicroWeave-ID		00H	(*1)
12H	Head actuator rank ID for lwC		00H	(*1)
13H	Head actuator rank ID for lwM		00H	(*1)
14H	reserved		00H	–

*1: See NOTE at the end of the section.

Table 7-14. EEPROM Address Map (2/8)

Address	Explanation	Settings	QPIT settings	Factory settings
15H	Bi-D Adjustment data (for Normal x3)	-36 <= n <= +36 (by 1/1440 inch)	00H	(*1)
16H	Bi-D Adjustment data (for Variable-2)	-36 <= n <= +36 (by 1/1440 inch)	00H	(*1)
17H	Bi-D Adjustment data (for Variable-1)	-36 <= n <= +36 (by 1/1440 inch)	00H	(*1)
18H	Uni-D Adjustment data	-36 <= n <= +36 (by 1/1440 inch)	00H	(*1)
19H	reserved		00H	–
1AH	reserved		00H	–
1BH	1st dot position adjustment data		00H	(*1)
1CH	reserved		00H	–
1DH	reserved		00H	–
1EH	reserved		00H	–
1FH	ERROR Code		00H	00H
20H, 21H, 22H, 23H	CPSI password		00H	00H
24H	CPSI license flag	0: disable 1: enable	00H	00H
25H	CPSI font license	0: disable 1: enable	00H	00H
26H	Interface selection	0: Auto 1: Parallel 2: Serial 3: USB 4: Option	00H	00H (*2)

*1, *2: See NOTE at the end of the section.

Table 7-15. EEPROM Address Map (3/8)

Address	Explanation	Settings	QPIT settings	Factory settings
27H	Interface time-out	0 to 255 (by second, value of 0 means 10 seconds)	0AH	0AH
28H	Compatibility speed	0: Fast 1: Slow 2: Special-1 3: Special-2	00H	00H
29H	ECP speed (*A)	0: Fast 1: Slow	00H	00H
2AH	IEEE1284.4 for Parallel	0: Auto 1: On 2: Off	00H	00H
2BH	I/F Control flags	bit1: ECP mode (0=Off, 1=On) (*B) bit0: IEEE1284 mode (0=On, 1=Off) (*C)	00H	00H
2CH	IEEE1284.4 for USB	0: Auto 1: On 2: Off	00H	01H
2DH, 2EH, 2FH	reserved for USB		00H	-

*A: BUSY signal delay time from fall-edge of a -STB signal. (Fast: Max. 1MB/s, Slow: Max. 600KB/s)

*B: Selects IEEE1284 transfer mode. (ECP pr Nibble)

*C: Enables or disables reverse transfer. (When disabled, ignore -SLN signal.)

*2: See NOTE at the end of the section.

Table 7-16. EEPROM Address Map (4/8)

Address	Explanation	Settings	QPIT settings	Factory settings
30H	Font	0: Roman 1: Sans Serif 2: Courier 3: Prestige 4: Script 10: Roman T 11: Sans Serif H 7: Draft	00H	02H
31H	Pitch	0: 10cpi 1: 12cpi 2: 15cpi 3: 17cpi 4: 20cpi 5: Proportional	00H	00H
32H	Print direction control	0: Bi-D 1: Uni-D 2: Auto	02H	02H
33H	CG table	0: Italic U.S.A 1: Italic France 2: Italic Germany 3: Italic U.K 4: Italic Denmark 5: Italic Sweden 6: Italic Italy 7: Italic Spain 8: PC 437 9: PC 437 Greek 10: PC 850 11: PC 860 12: PC 863 13: PC 865 14: PC 861 15: BRASCII 16: Abicomp 17: Roman 8 18: ISO Latin1 19: PC 853 20: PC 855 21: PC 852 22: PC 857 23: PC 866 24: PC 869 25: MAZOWIA 26: Code MJK 27: ISO 8859-7 28: ISO Latin 1T 29: Bulgaria 30: PC 774 31: Estonia 32: ISO 8859-2 33: PC 866 LAT 34: PC 866UKR 35: PC AR864 36: PC APTEC 37: PC 708 38: PC 720 39: Hebrew7 40: Hebrew8 41: PC 862 42: PC 858 43: ISO 8859-15	08H	08H

Table 7-17. EEPROM Address Map (5/8)

Address	Explanation	Settings	QPIT settings	Factory settings
34H	Software A.G.M. Auto CR Zero Slash - - Network I/F mode Auto LF	bit7: Software (0=ESC/P, 1=IBM) bit6: A.G.M. (0=Off, 1=On) bit5: Auto CR (0=Off, 1=On) bit4: Zero slash (0=Off, 1=On) bit3: Reserved bit2: Reserved bit1: Network I/F mode (0=Off, 1=On) bit0: Auto line feed (0=Off, 1=On)	00H	00H
35H	Panel mask function	bit7: Entry Self-Test bit6: Entry Hex-Dump bit5: Extended settings bit4: Reserved bit3: Reserved bit2: Cleaning bit1: Replace I/C bit0: Load/Elect	00H	00H
36H	Top margin	42 to 44 x 360 (by 1/360 inch)	00H	00H
37H			78H	78H
38H	Bottom margin	1244 to 44 x 360 (by 1/360 inch)	1EH	1EH
39H			F0H	F0H
3AH	Page length	1244 to 44 x 360 (by 1/360 inch)	1EH	1EH
3BH			F0H	F0H
3CH	reserved for main		00H	-
3DH	reserved for main		00H	-
3EH	reserved for main		00H	-
3FH	reserved for main		00H	-

Table 7-18. EEPROM Address Map (6/8)

Address	Explanation	Settings	QPIT settings	Factory settings
40H	Password 1		0FH	-
41H			5AH	-
42H	Ink flag 1	bit7: Reserved bit6: black one-time bit5: color one-time bit4: Initial fill required bit3: Reserved bit2: ink cleaning seq. bit1: black CL required bit0: color CL required	00H	10H
43H	Ink flag2	bit2: YMC cartridge changed and cleaned bit1: Black cartridge changed and cleaned bit0: Black cartridge changed and cleaned	00H	00H
44H, 45H, 46H, 47H	Ink counter Cb		00H	00H
48H, 49H, 4AH, 4BH	Ink counter Cy		00H	00H
4CH, 4DH, 4EH, 4FH	Ink counter Cm		00H	00H
50H, 51H, 52H, 53H	Ink counter Cc		00H	00H
54H, 55H, 56H, 57H	Ink counter Clm		00H	00H
58H, 59H, 5AH, 5BH	Ink counter Clc		00H	00H
5CH, 5DH	Ink counter Rb0		00H	00H

Table 7-19. EEPROM Address Map (7/8)

Address	Explanation	Settings	QPIT settings	Factory settings
5EH, 5FH	Ink counter Ry0		00H	00H
60H, 61H	Ink counter A0		00H	00H (*3)
62H, 63H	Power off time		00H	00H (*2)
64H, 65H	CL time		00H	00H (*2)
66H, 67H	accumulated printing time		00H	00H
68H, 69H	reserved for ink-system		00H	–
6AH, 6BH, 6CH, 6DH, 6EH, 6FH, 70H, 71H, 72H, 73H, 74H, 75H, 76H, 77H, 78H, 79H, 7AH, 7BH, 7CH, 7DH, 7EH, 7FH	Printer-ID Strings[22]		00H	00H
80H	Password 2		0FH	–
81H			5AH	–
82H	Ink end by Head temperature		00H	00H
83H	P2		00H	00H
84H	P1		00H	00H
85H	Temperature at Bi-D adjustment (refer to EEPROM 15H)		00H	00H

*2, *3: See NOTE at the end of the section.

Table 7-20. EEPROM Address Map (8/8)

Address	Explanation	Settings	QPIT settings	Factory settings
86H	Temperature at Bi-D adjustment (refer to EEPROM 16H)		00H	–
87H	Temperature at Bi-D adjustment (refer to EEPROM 17H)		00H	–
88H	reserved		00H	–
89H	reserved		00H	–
8AH	Head TG-ID	0: Sharp 1: SEC	00H	(*1)
8BH	reserved		00H	–
8CH, 8DH, 8EH, 8FH	Total count of Paper through		00H	00H
90H, 91H	Ink counter Rb80		00H	00H
92H, 93H	Ink counter Ry80		00H	00H
94H, 95H	Ink counter A80		00H	00H
96H, 97H, 98H, 99H	Total count of CR seek		00H	00H
9AH, 9BH, 9CH, 9DH, 9EH, 9FH	reserved		00H	–

NOTE:

*1: Adjusted at factory.

*2: Initialized after panel initialization is performed.

*3: Initialized after initialization of the ink overflow counter in EEPROM is performed.

7.3 Component Layout

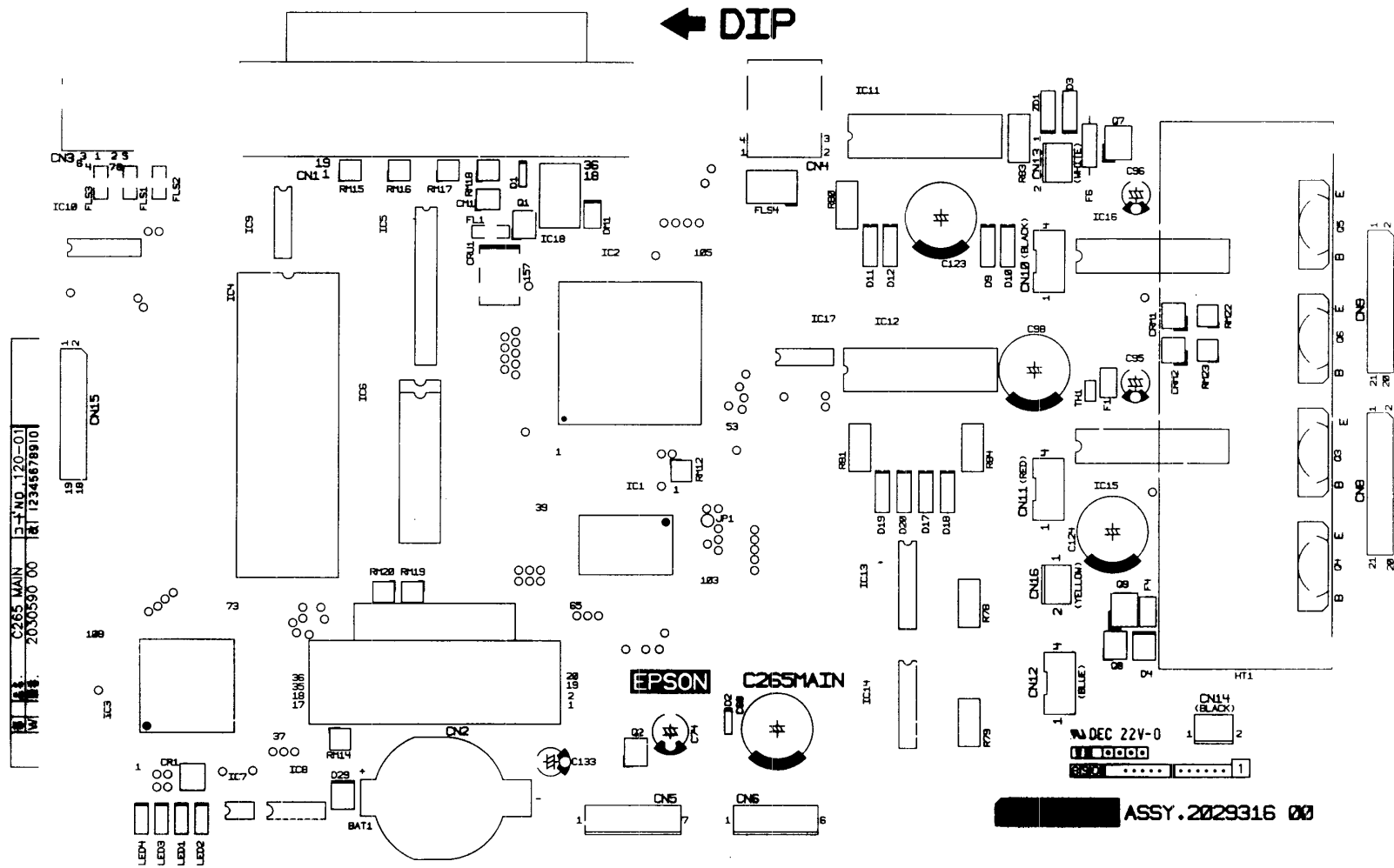

Figure 7-2. C380 Main Board (Component side)

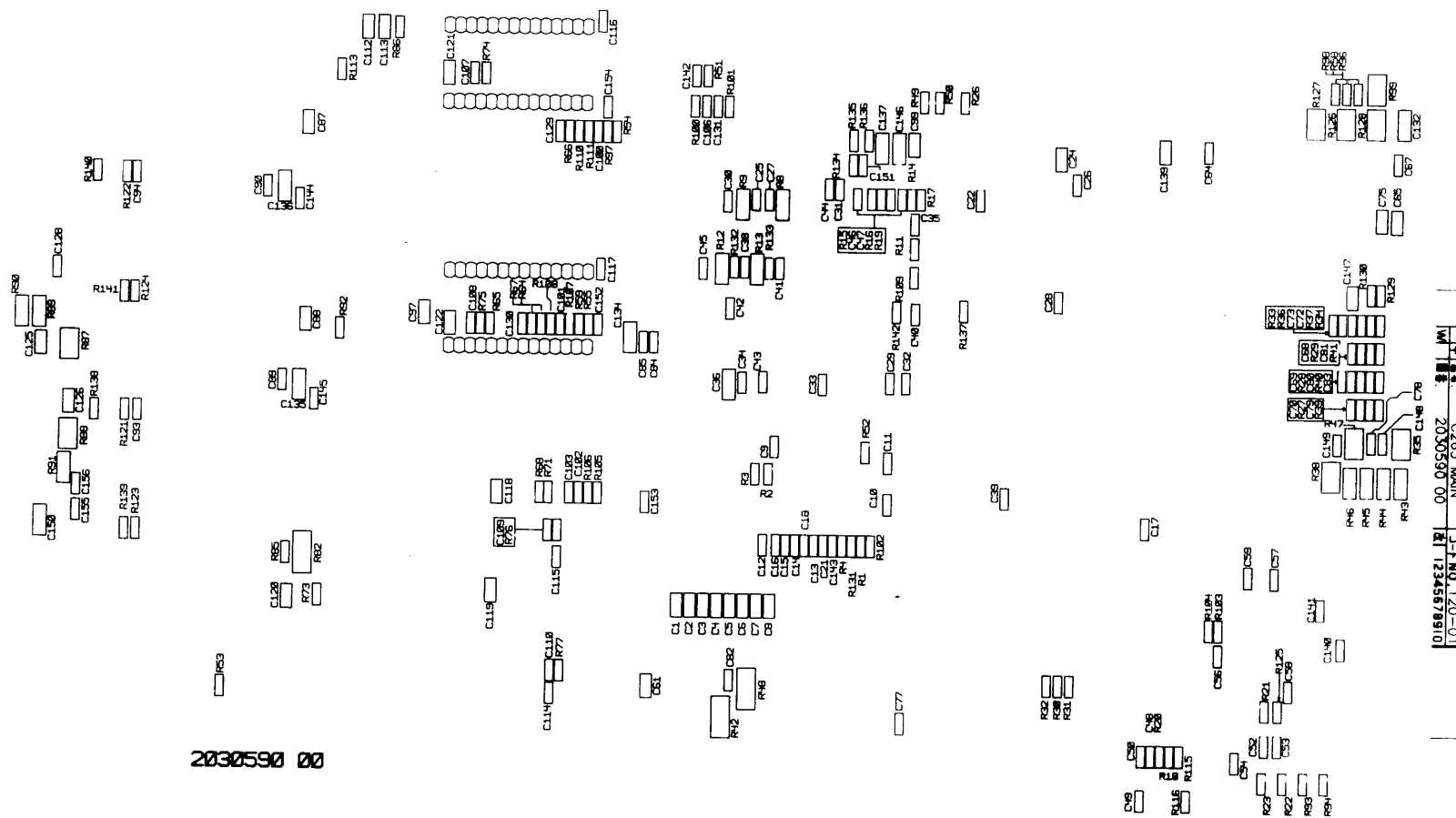

Figure 7-3. C380 Main Board (Soldering side)

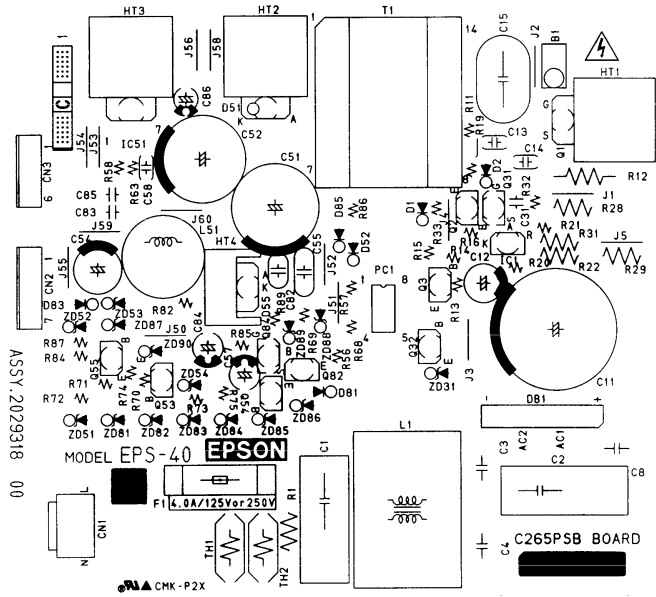

Figure 7-4. C265 PSB Board

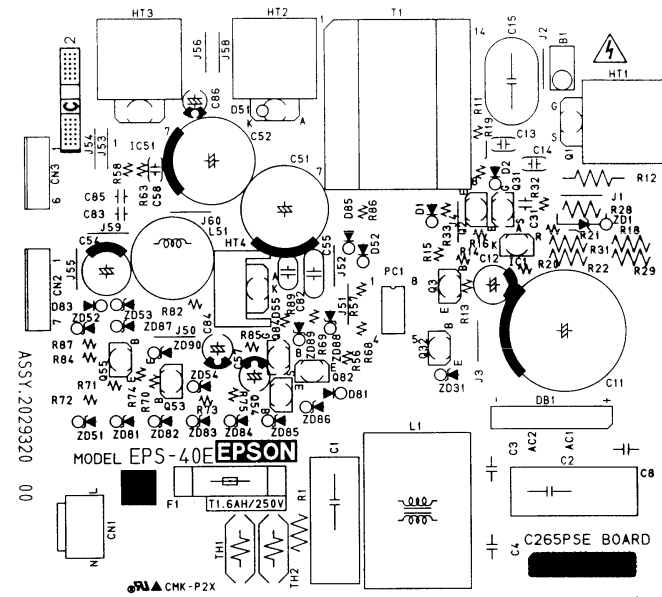

Figure 7-5. C265 PSE Board

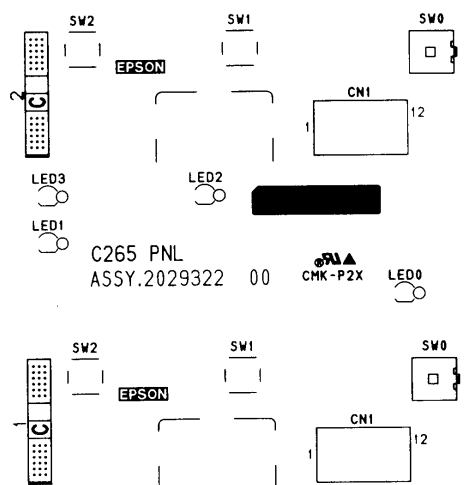

Figure 7-6. C265 PNL Board

7.4 Parts List

Table 7-21. Parts List (1/6)

No.	Description	No.	Description
100	HOUSING, UPPER	119	LOCK, STACKER
101	HOUSING, LOWER; B	120	COMPRESSION SPRING, 2.94
102	COVER, PRINTER	121	SHIELD PLATE, MAIN, UPPER, RIGHT
103	PAPER SUPPORT ASSY	122	SHIELD PLATE, MAIN, UPPER, LEFT
104	HOUSING, REAR ASSY.	123	GROUNDING PLATE, I/F, UPPER
105	COVER, CONNECTOR, UPPER	124	GROUNDING PLATE, I/F
106	STACKER ASSY.; C	125	GUIDE, I/F BOARD
107	HOUSING, PANEL, RIGHT	126	SHIELD PLATE, MAIN, UPPER, I/F
108	KEY TOP	129	SHIELD PLATE, P/S, LOWER
109	OPTICAL PLATE	130	SHIELD PLATE, P/S, UPPER
110	SLEEVE, OPTICAL PLATE	131	GROUNDING PLATE, P/S
111	SHEET, PROTECT, PANEL	132	SHIELD PLATE, P/S, UPPER, RIGHT
112	HOUSING, PANEL, LEFT	133	SPACER, SHIELD PLATE
113	POROUS PAD, INK EJECT, L	134	FOOT, P/S
114	POROUS PAD, INK EJECT, R	135	MOUNTING PLATE, FAN
115	LOGO PLATE, 10X40; C	136	GUIDE, FRAME, FAN
116	COVER, POROUS PAD, INK EJECT	137	SHIELD PLATE, I/F
117	SPACER, POROUS PAD, INK EJECT	138	SHIELD PLATE, MAIN, LOWER
118	FOOT	139	GROUNDING PLATE, M/B

Table 7-22. Parts List (2/6)

No.	Description	No.	Description
140	GUIDE, SHIELD PLATE	334	WIRE HARNESS
142	CLAMP	335	FAN ASSY
145	C.P.SCREW	400	POWER CABLE ASSY.
146	C.B.S. SCREW	450	BOARD ASSY., PANEL
147	C.B.S. SCREW	500	PRINTER MECHANISM(ASP)M4P11-100
148	C.B.S-TITE SCREW	501	FRAME, UPPER
149	C.B.S-TITE SCREW	502	FRAME, LOWER
150	C.B.P-TITE SCREW, 3X8, F/ZN	503	FRAME ASSY., LEFT
151	C.B.P-TITE, 3X10, F/ZN	504	FRAME, RIGHT
152	C.B.SCREW, 4X14, F/ZN	505	FRAME, GUIDE, CR
154	C.B.P-TITE SCREW, 3X6, F/ZN	506	LEVER, PG; B
155	C.P.P-TITE SCREW, 4X12, F/ZN	507	TORSION SPRING, 64.7
156	C.B.(O) SCREW 4X8 F/ZG	508	TIMING BELT
157	SLEEVE 2.5MM ASP	509	HOLDER, PULLEY, DRIVEN
158	GROUNDING PLATE, CN	510	PULLEY, DRIVEN
180	LABEL, CAUTION	511	SHAFT, PULLEY, DRIVEN
182	LABEL, ACCESSORY; F	512	BUSHING, PULLEY, DRIVEN
200	BOARD ASSY., MAIN	513	COMPRESSION SPRING, 48
300	BOARD ASSY., POWER SUPPLY	514	INK SYSTEM ASSY.;B
330	WIRE HARNESS	515	MOTOR ASSY., PF
331	WIRE HARNESS	516	GROUNDING PLATE, FRAME, LOWER
332	WIRE HARNESS	517	LINEAR SCALE
333	WIRE HARNESS	518	PAPER GUIDE, RIGHT

Table 7-23. Parts List (3/6)

No.	Description	No.	Description
519	PAPER GUIDE, UPPER	541	CLANP
520	PAPER GUIDE, LEFT	542	SHEET, COVER, M/B
521	SHAFT, PAPER GUIDE, UPPER	543	CLEANER, HEAD, ASP
522	TORSION SPRING, 117.6	545	SHAFT, CR, GUIDE
523	SHAFT, ROLLER, DRIVEN	546	LEVER, PG, SUB
524	ROLLER, DRIVEN;E	547	OIL PAD
525	HOLDER, LINEAR SCALE	548	COVER, CARTRIDGE, BK; C
526	EXTENTION SPRING, 2.13	549	COVER, CARTRIDGE, C; D
527	BUSHING, PARALLEL, ADJUST, LEFT	552	LIFTER, CARTRIDGE, BK
528	BUSHING, PARALLEL, ADJUST, RIGHT	553	LIFTER, CARTRIDGE, C
529	HOLDER, FFC, RIGHT	554	DETECTOR, I/C
530	BOARD ASSY., SUB	555	HARNESS, DETECTOR, IC
531	PAPER SUPPORT, SUUPPORT, UPPER	556	HARNESS, ENCODER
532	FRAME ASSY., PAPER SUPPORT	557	CARRIAGE ASSY.
533	EXTENSION SPRING, 0.29	558	GROUNDING PLATE, HEAD
534	HOLDER, DETECTOR, PE	559	LEVER, HEAD, ADJUST
535	LEVER, DETECTOR, PE	560	LEVER, HEAD, FASTEN
536	TORSION SPRING, 0.22	561	BOARD ASSY., ENCODER
537	CIRCUIT ASSY, PE	562	HOLDER, BOARD, ENCORDER
538	HARNESS, PE	563	PLATE, SLIDE, CLEANER
539	DETECTOR, HP; E	564	SLIDER, CR
540	HARNESS, HP	565	TORSION SPRING, 98

Table 7-24. Parts List (4/6)

No.	Description	No.	Description
566	LEVER, DETECTOR, IC, BK	589	ROD SPRING, STAR WHEEL
567	LEVER, DETECTOR, IC, C	590	STAR WHEEL ASSY, 8;D
568	TORSION SPRING, 2.04	591	HOLDER, FFC, CENTER
569	COVER, DETECTOR, IC	592	HOLDER, FFC, LEFT
570	MOTOR ASSY., CR	593	CABLE, HEAD, SHORT
571	INSULATOR, MOTOR, CR	594	CABLE, HEAD, LONG
572	SPACER, INSULATOR	595	SPUR GEAR, 16.5
573	FRAME, MOTOR, CR	596	BUSHING, 6
574	HEXAGON NUT	597	BUSHING, 12
575	HOLDER, FFC, CR	599	BUSHING, 12, LEFT
577	SPUR GEAR, 18	600	COMPRESSION SPRING, 5.85
578	PAPER GUIDE, REAR	601	SPACER, FASTEN, ROLLER, PF
579	ROLLER, PF	602	SPACER, FASTEN, ROLLER, PF;B
580	PAPER GUIDE, FRONT	603	COMBINATION GEAR, 22, 81
581	ROLLER, PAPER EJECT	604	C-RING
582	FRAME, PAPER EJECT	605	SCALLOP SPRING PIN-AW, 2X16, F/B
583	ANTI STATIC CLOTH	606	FRAME SUB ASSY., DE
584	HOLDER, STARWHEEL, FRONT	607	MOTOR ASSY., ASF
585	HOLDER, STAR WHEEL, RIGHT	608	SOLENOID
586	HOLDER, STAR WHEEL, LEFT	609	LEVER, TRIGGER
587	HOLDER ASSY., STAR WHEEL, RIGHT, ASP	610	EXTENTION SPRING, 0.21
588	HOLDER ASSY., STAR WHEEL, LEFT, ASP	611	SHAFT, DE, PLANET

Table 7-25. Parts List (5/6)

No.	Description	No.	Description
612	LEVER, CHANGE	637	HOLDER, SHEET, PAPERFEED
613	COMBINATION GEAR, 14.4, 24	638	ROLLER ASSY, LD, LEFT
614	SPUR GEAR, 20.8	639	ROLLER ASSY, LD, RIGHT
615	COMBINATION GEAR, 12.8, 27.2	640	COVER, ROLLER, LD, LEFT
616	COMBINATION GEAR, 20, 38.4	641	COVER, ROLLER, LD, RIGHT
617	SPUR GEAR, 26.25	642	COMPRESSION SPRING, 1.961
620	FRAME, ASF	643	PAPER LOADING ASSY., RIGHT
621	WHEEL, DETECT	644	PAPER LOADING ASSY., LEFT
622	LEVER, FASTEN, EDGE GUIDE;B	647	FERRITE CORE
623	EXTENSION SPRING, 0.088	658	SPUR GEAR, 27.2
624	SHAFT, ROLLER, LD	659	HARNES, ASF
625	LEVER, HOPPER, RELEASE	663	C.B.P-TITE(P4), 3X8, F/ZN
626	HOPPER	664	C.P.SCREW, M3X3
627	REINFORCEMENT PLATE, HOPPER	665	C.B.P-TITE SCREW, 3X6, F/ZN
628	EDGE GUIDE; D	666	C.P.P-TITE SCREW, 4X12, F/ZN
629	SLIDER, EDGE GUIDE	667	C.B.P-TITE, 2.5X5, F/ZN
630	COMPRESSION SPRING, 3.23	668	C.B.S. SCREW
631	PAD, BREAK, EDGE GUIDE	669	RETAINING RING
632	CORK	670	RETAINING RING
633	CORK;B	671	RETAINING RING
634	SHAFT, MOUNT, CR	672	PLAIN WASHER 6.1X0.5X12, F/NI
635	C.P.S-TITE(P4), 3X6, F/ZN	673	PLANE WASHER, 12.2X0.5X15
636	SHEET, PAPERFEED	674	PLAIE WASHER

Table 7-26. Parts List (6/6)

No.	Description	No.	Description
675	PLANE WASHER	721	EXTENSION SPRING, 0. 62
676	LEAF SPRING	722	LEVER, PAPERRETURN, RIGHT
677	LEAF SPRING	723	EXTENSION SPRING, 0. 294
678	U-TYPE S.W.	724	ROLLER, LD, SUPPORT
679	FERRITE, CLAMP	725	HOLDER, ROLLER, LD, SUPPORT, RIGHT
680	SHEET, PRESSING PLATE, HP	726	PAD ASSY., LEFT
681	GUIDE, PAPER EJ.	727	LEVER, PAD, RELEASE, LEFT
682	CLAMP, FERRITE CORE	728	HOLDER, EDGE GUIDE, LEFT
683	SPACER, FRAME, IS	729	LEVER, PAPERRETURN, LEFT
685	CLAMP, CABLE	730	HOLDER, ROLLER, LD, SUPPORT, LEFT
700	PRINT HEAD, IJ480-0AA	800	ASF UNIT
716	PAD ASSY., RIGHT	3	PAD PRINTER
717	LEVER, PAD, RELEASE, RIGHT	4	PAD, ACCESSORY
718	PAD SRRING, HOLDER, PAD	5	PAD, STACKER
719	HOLDER, EDGE GUIDE, RIGHT	6	RLASTIC PROTECTIVE BAG, 510X870X0.05T
720	COMPRESSION SPRING, 1. 17	7	PAD, ASF

7.5 Exploded Diagrams

See the following pages for the Exploded diagrams.

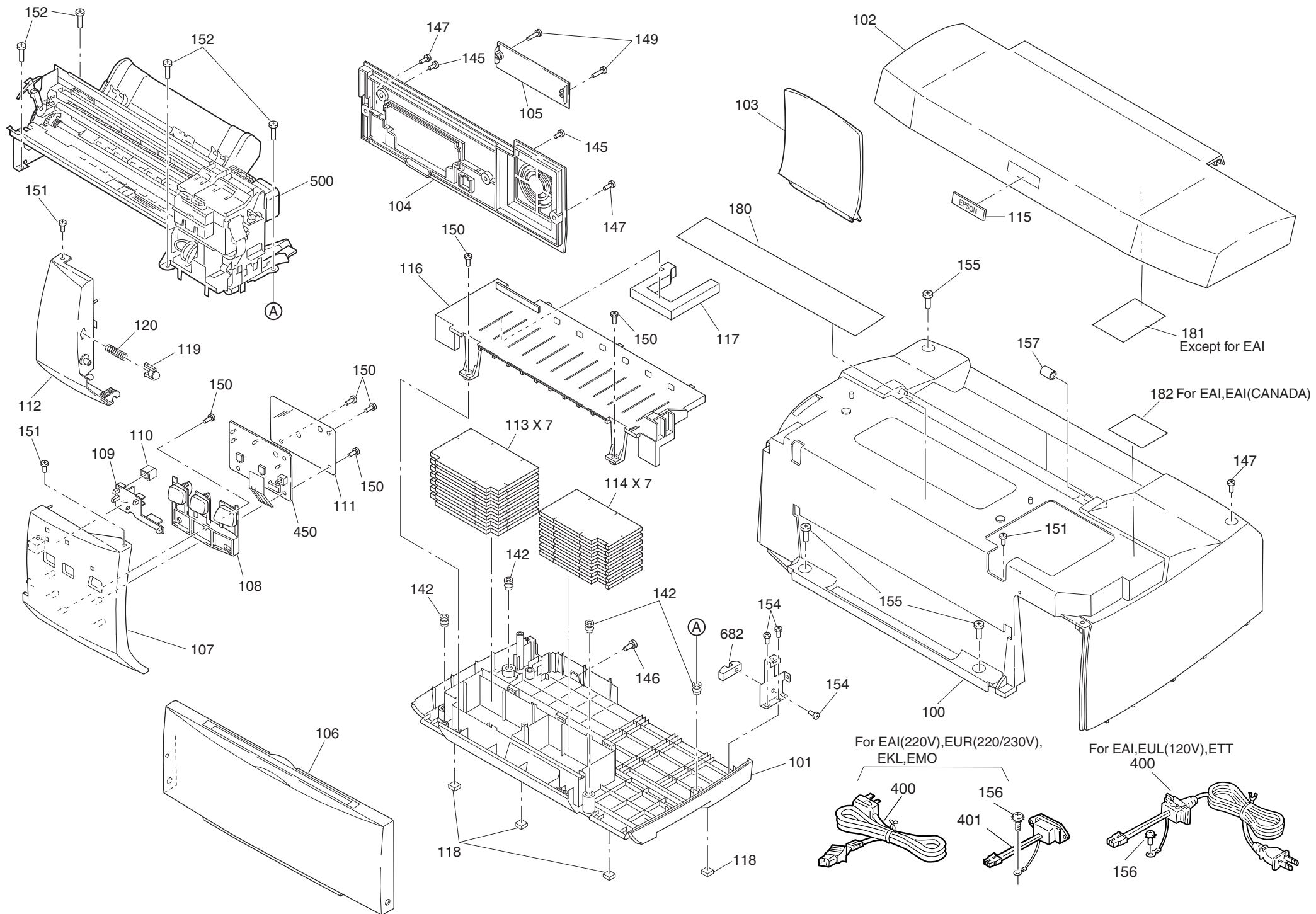

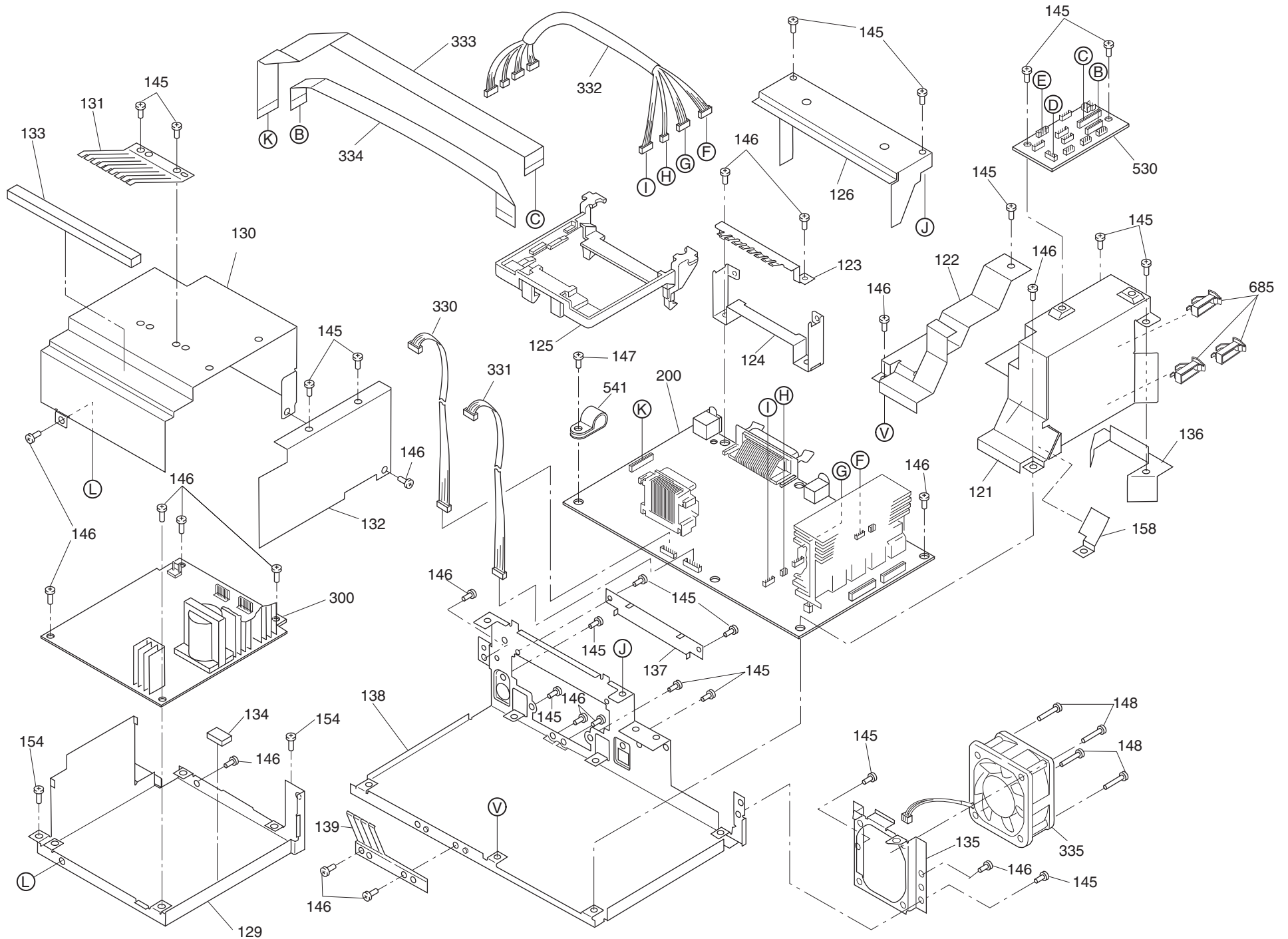

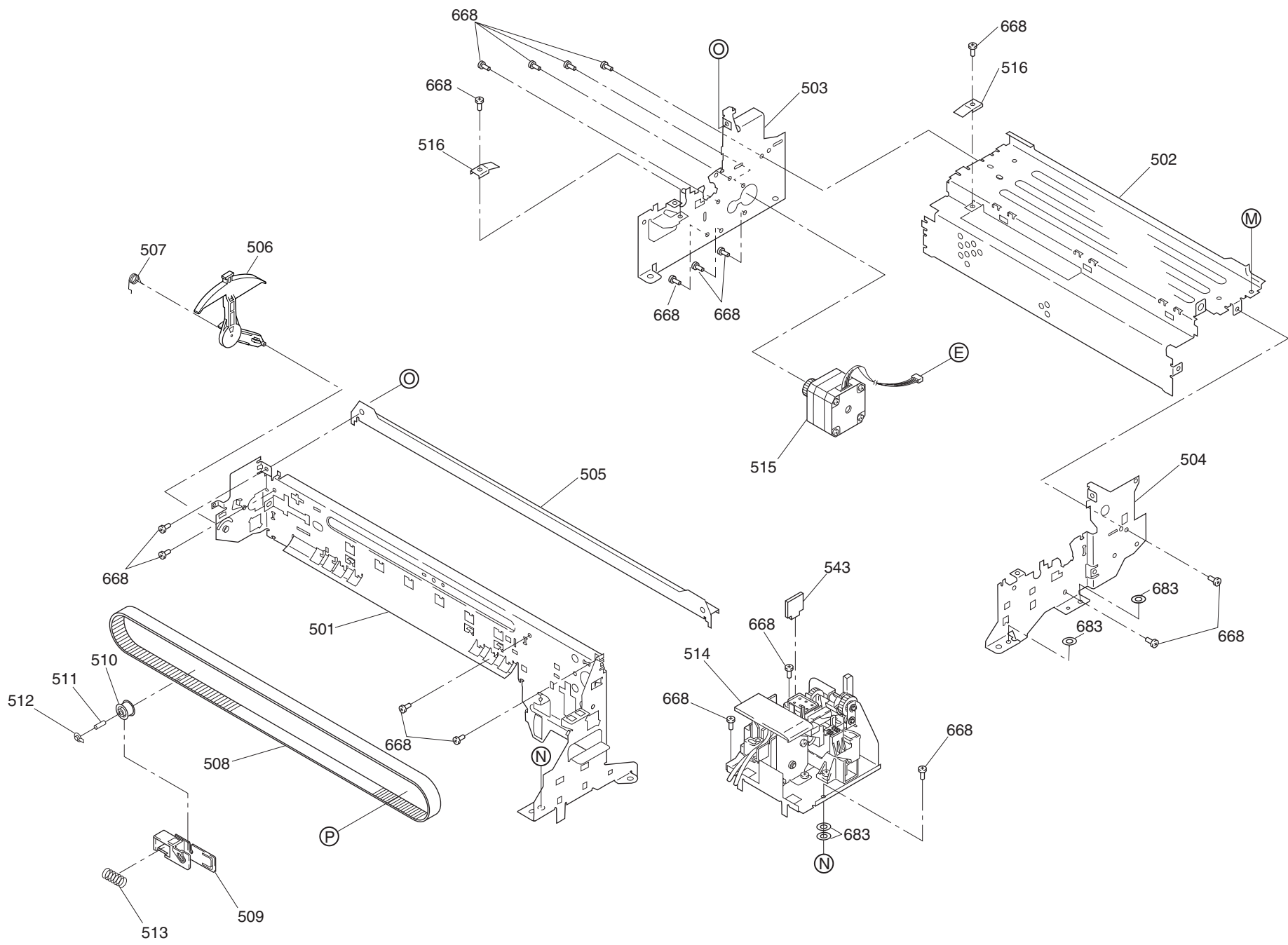

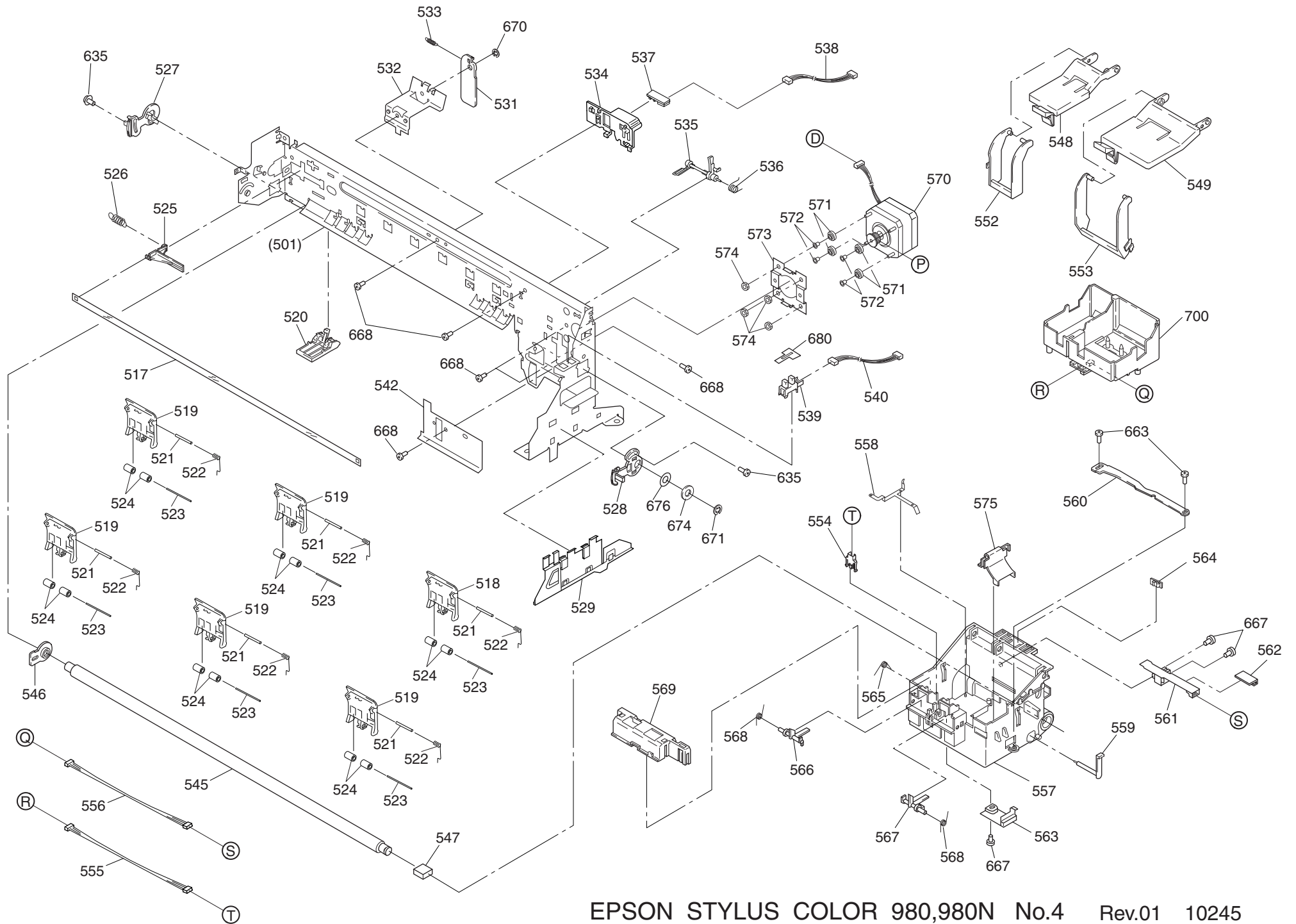

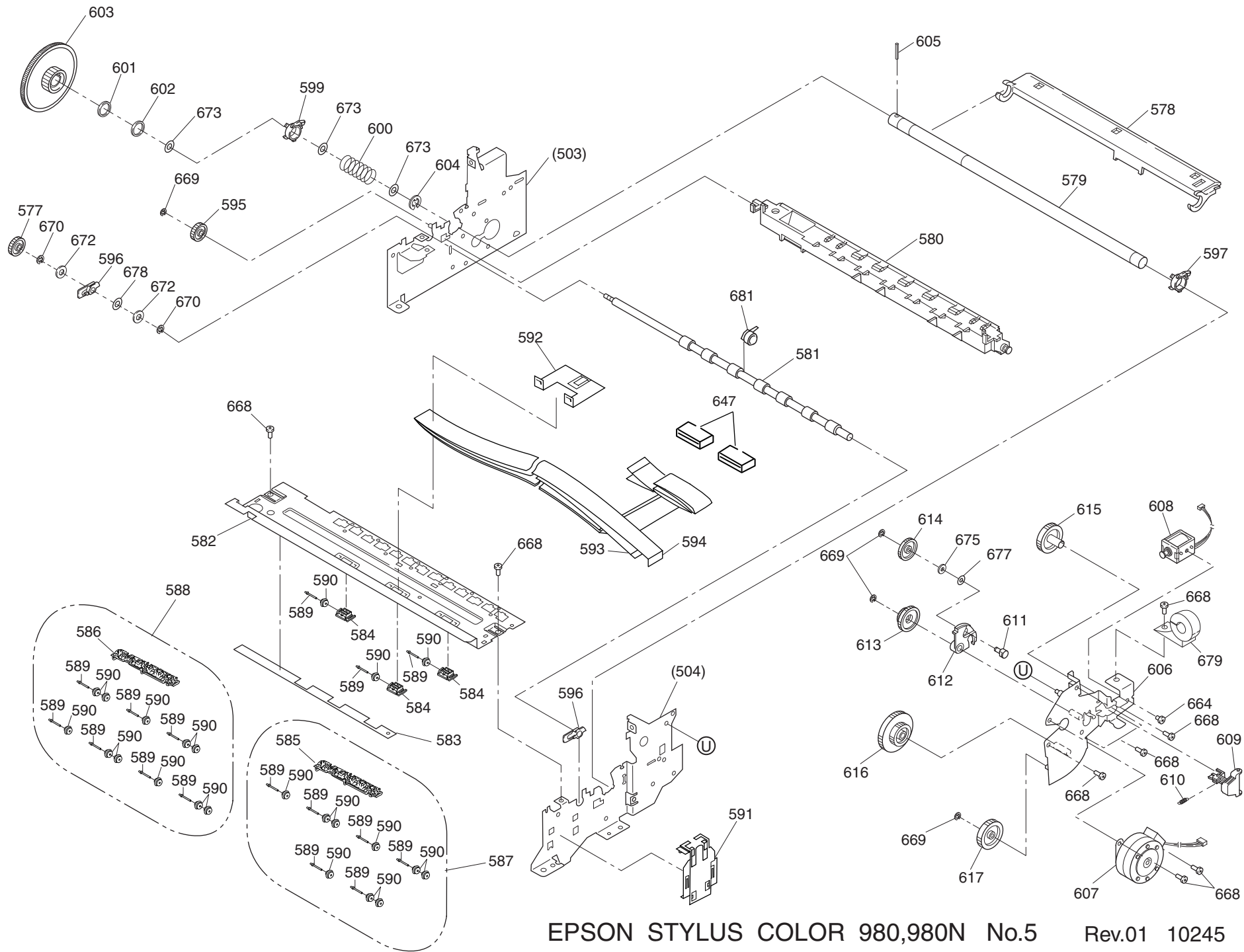

EPSON STYLUS COLOR 980,980N No.5 Rev.01 10245

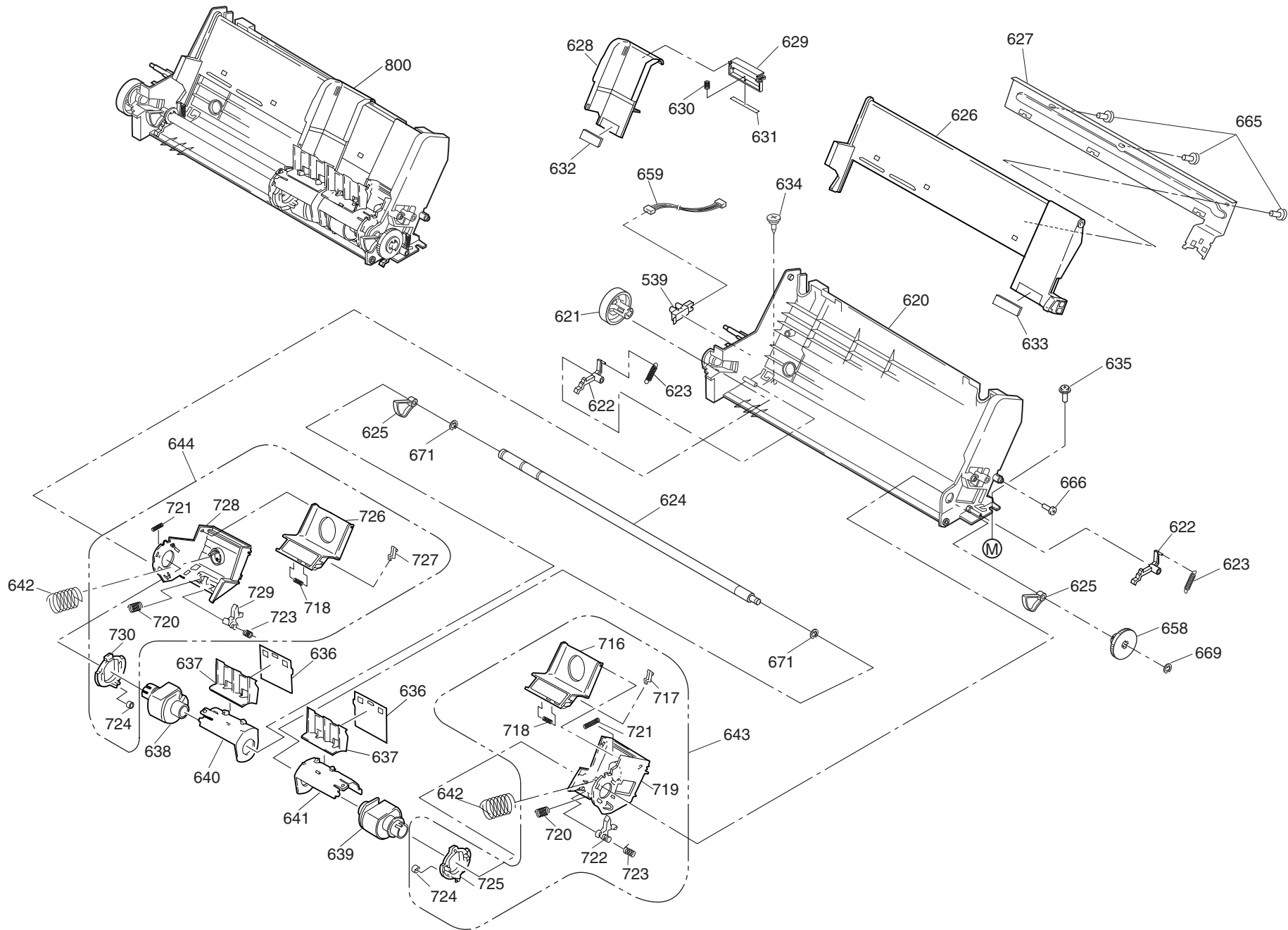

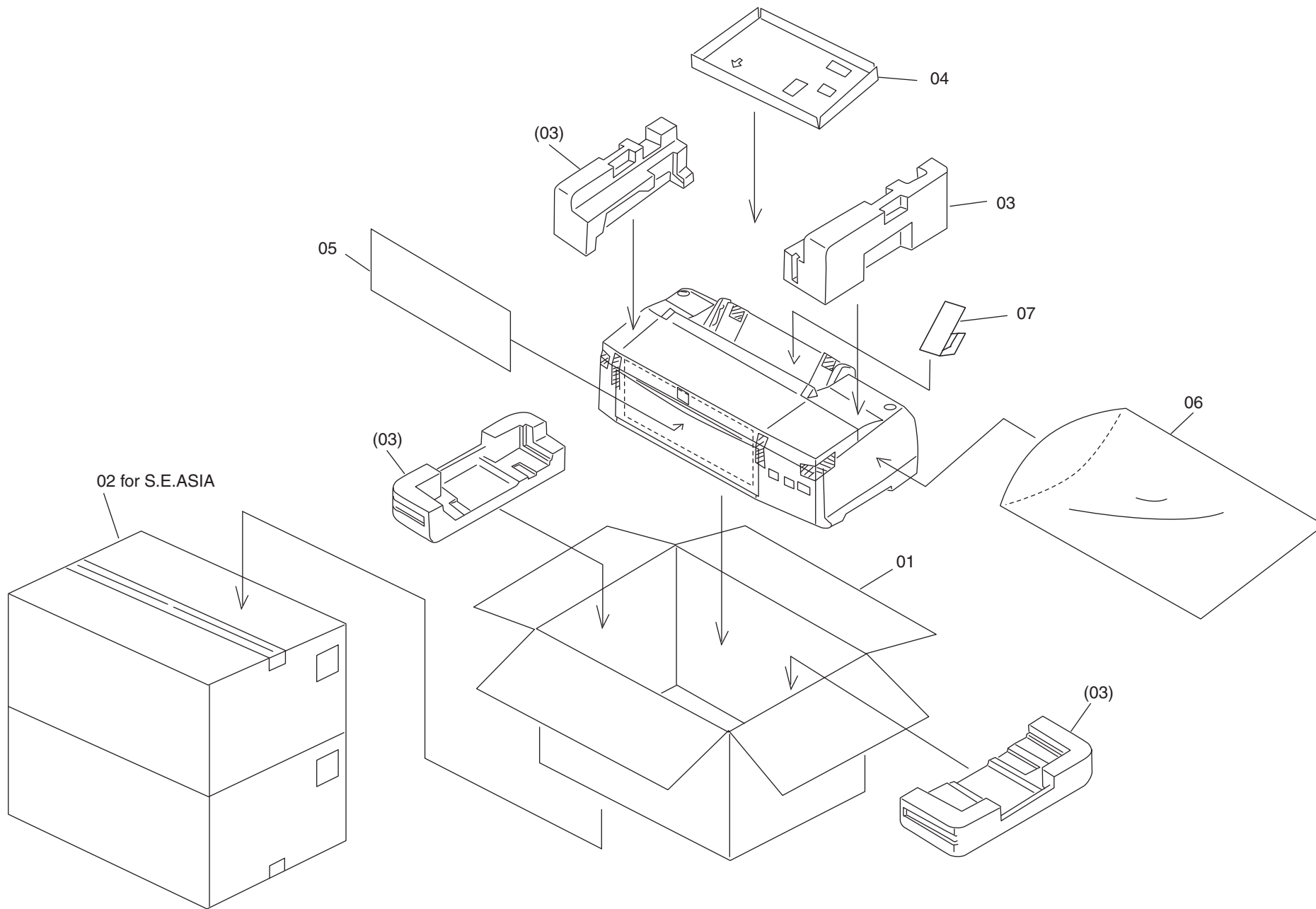

7.6 Circuit Diagrams

See the following pages for the circuit diagrams below.

- C380 Main Board (1/2)
- C380 Main Board (2/2)
- C265 PSB Board
- C265 PSE Board
- C265 PNL Board

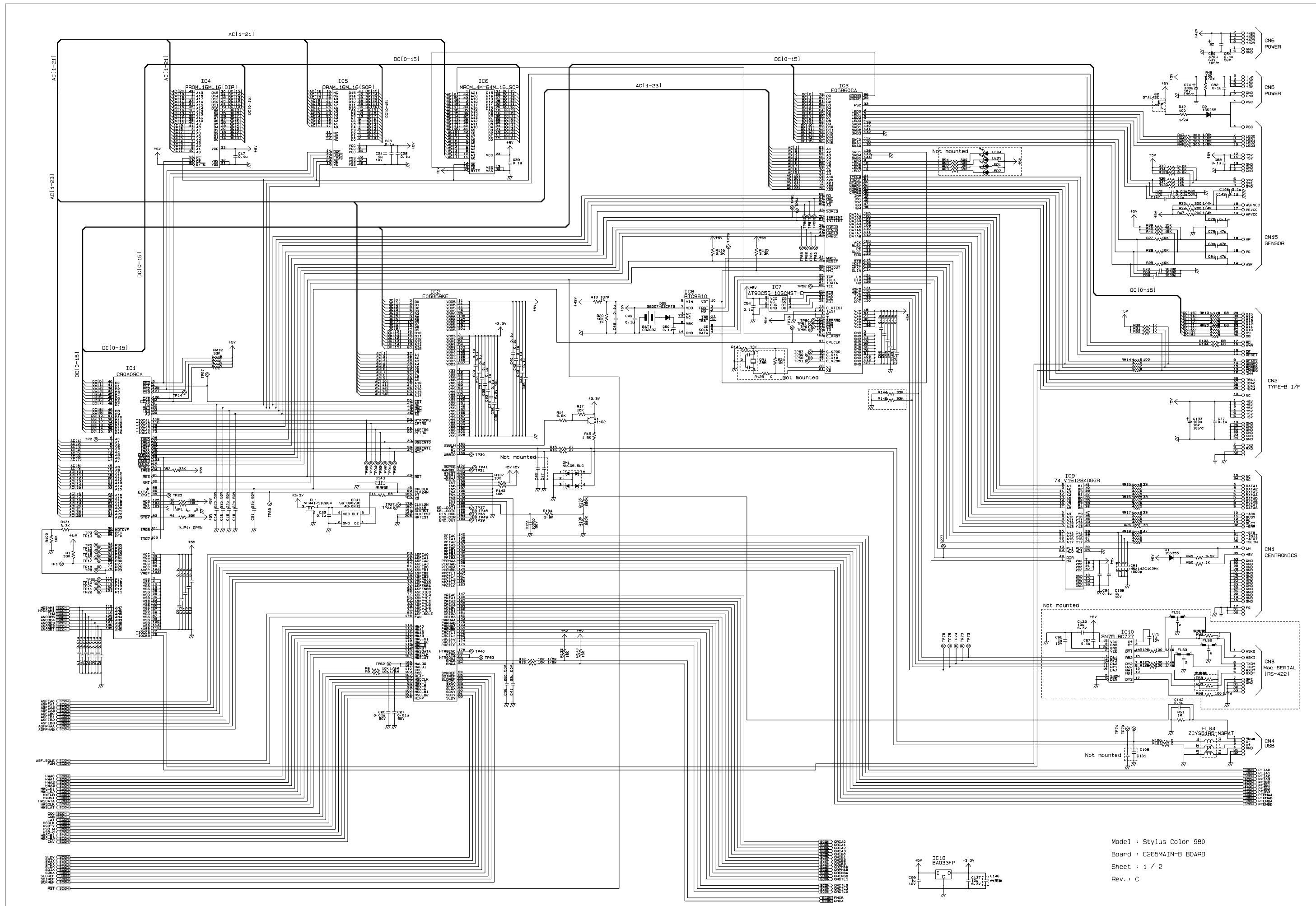

Model : Stylus Color 980
 Board : C265MAIN-B BOARD
 Sheet : 1 / 2
 Rev. : C

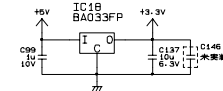

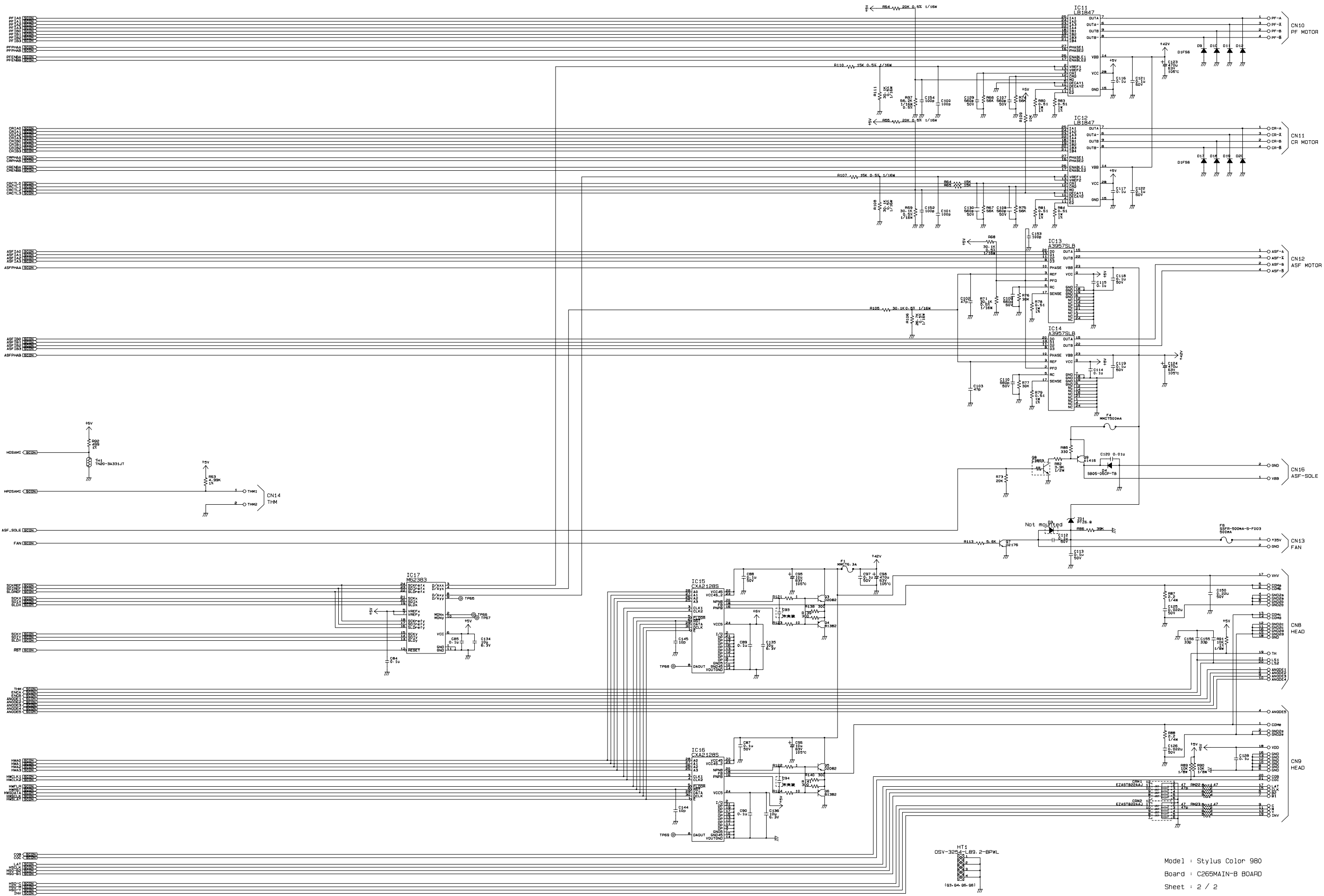

Model : Stylus Color 980
 Board : C265MAIN-B BOARD
 Sheet : 2 / 2
 Rev : C

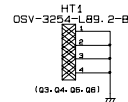

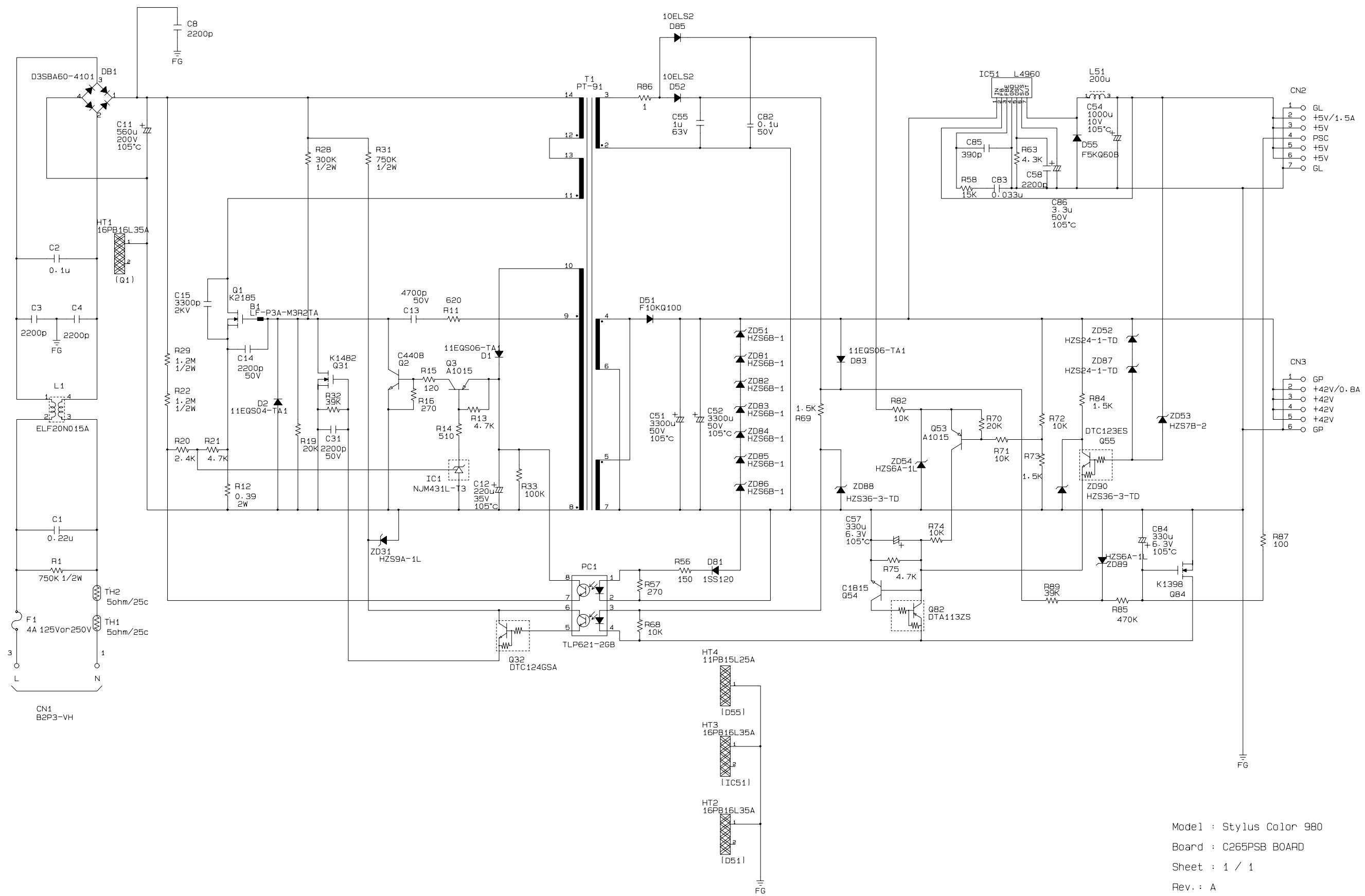

Model : Stylus Color 980
 Board : C265PSB BOARD
 Sheet : 1 / 1
 Rev. : A

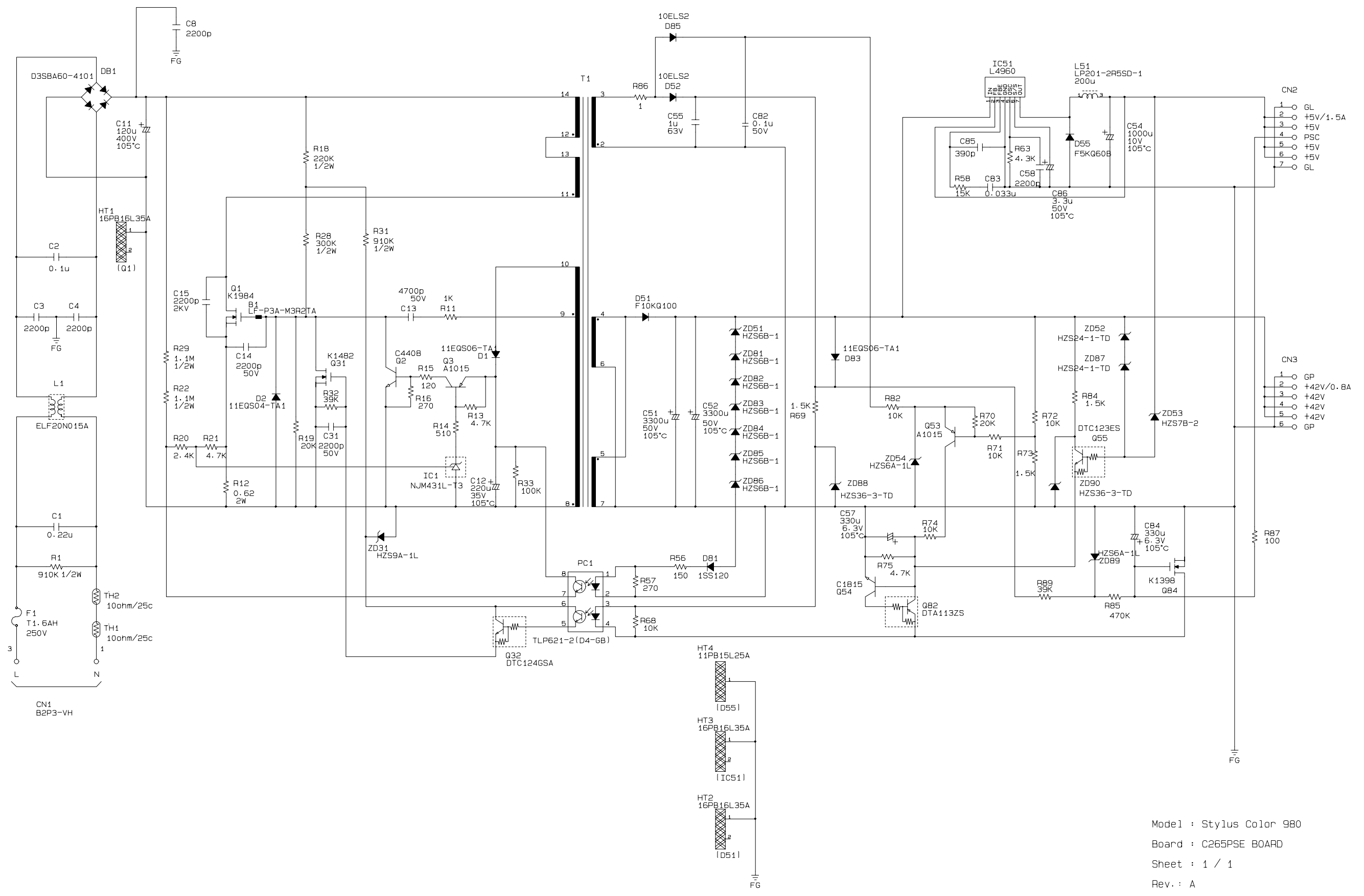

Model : Stylus Color 980
 Board : C265PSE BOARD
 Sheet : 1 / 1
 Rev. : A

1

2

3

4

5

6

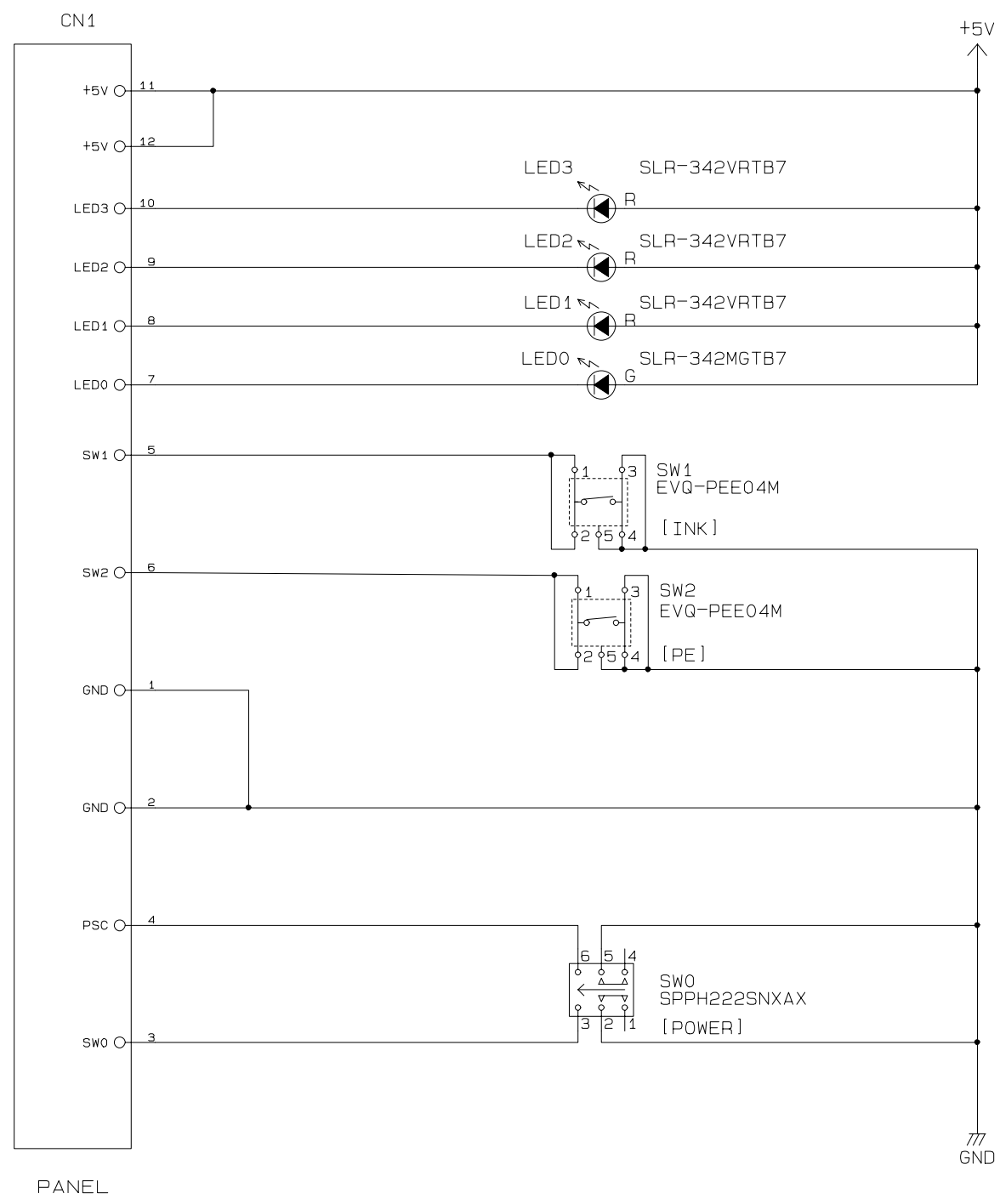

Model : Stylus Color 980
 Board : C265PNL BOARD
 Sheet : 1 / 1
 Rev. : A